

## 1974 ALL MODELS

American Motors  
Chrysler Corp.  
Ford Motor Co.  
General Motors

### DESCRIPTION

**American Motors** – A rear window defogger system is available on Gremlin and Hornet models. Components of system consist of a grid and buss bars fused to inside of glass, a control switch, pilot light, and timer relay.

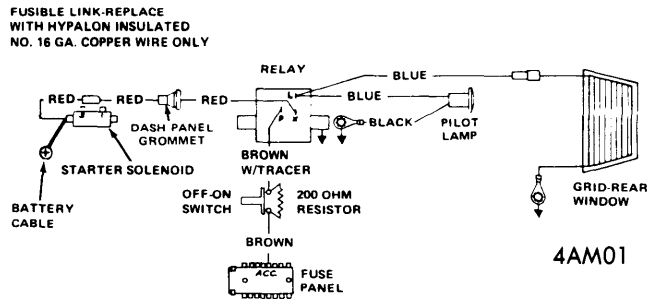

### AMERICAN MOTORS HEATED REAR WINDOW WIRING

The feed wire to the grid is attached to a separate wire harness which is connected to the defogger relay. Current feed to the relay is by a wire attached to the battery side of the starter solenoid. Included in this wire is a fusible link to protect the circuit.

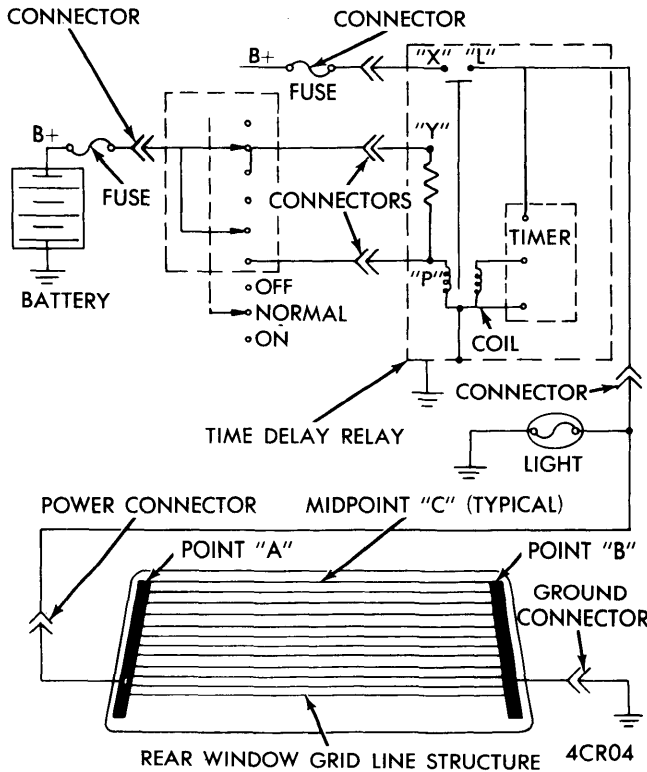

### CHRYSLER CORP. HEATED REAR WINDOW WIRING

**Chrysler Corp.** – Heated rear window system consists of a glass with a series of electrically conductive grid lines baked on inside of glass, a control switch and delay relay.

**General Motors** – Available as an option, the back window defogger system makes use of a number of horizontal ceramic silver compound element lines (conductors) and two vertical bus bars (one at each end of the element lines). These components are baked into the inside surface during the glass forming operation, and form a grid that warms the glass when the control switch is ON.

Braided wire is soldered to the bus bars on each side of the glass. The lead wires (one to ground, one to 12 volts positive) are spliced to the braided wire and then covered with a plastic sleeve insulator.

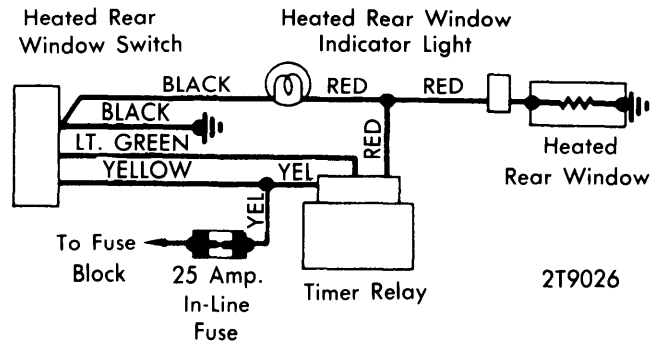

### CADILLAC HEATED REAR WINDOW WIRING

**Ford Motor Co. (Exc. Quick Defrost Unit)** – System incorporates a series of grid wires baked on inside surface of rear window. Grid wires are heated by current from control switch and relay.

**Ford Motor Co. Quick Defrost Unit** – Quick defrost windshield and rear window system is available on Thunderbird and Continental Mark IV vehicles. System consists of a special front windshield and rear window glass, a separate three phase high voltage alternator, a two stage electrical timer, a control switch, indicator light and special wiring to carry high voltage current between alternator and glass. Heater elements in front and rear glass are composed of a thin film of gold metal deposited throughout glass. Almost the entire area of windows are uniformly heated.

### OPERATION

**American Motors** – Actuating the defogger control switch on the instrument panel when the ignition switch is ON causes the defogger relay points to close. A timer, enclosed in the relay case, will allow the defogger to operate for about 3 to 7 minutes, depending on the ambient temperature or until the ignition switch is turned off. The system can be recycled by again actuating the control switch.

**Chrysler Corp.** – Control switch is a three position switch and is spring loaded to return from "ON" or "OFF" to its center or "NORMAL" position. Switch connects power from ignition switch to internal holding resistor in series with a relay coil. When turned on, relay coil is energized closing relay contacts and providing power to rear window. When control switch returns to "NORMAL" position, current through relay and holding resistor is sufficient to maintain relay coil energized and contacts closed. Relay coil remains energized 3 to 7 minutes governed by timer circuit, or until switch is turned to "OFF" position. Time delay system has an electronic timing circuit in relay.

## 1974 ALL MODELS (Cont.)

**General Motors** – System operates on 12 volts with a current draw of approximately 20 amps with the glass at 75° F. Under certain ambient temperature conditions, it is possible that heat from the glass may not be detected by finger touch.

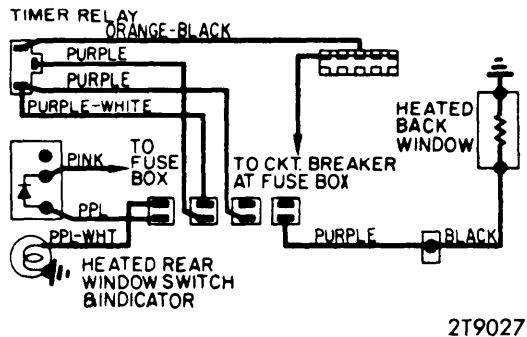

### BUICK HEATED REAR WINDOW WIRING

The system is actuated by an instrument panel mounted switch with an integral indicator lamp. Once the switch has been activated, the system operates continuously until the control switch or ignition switch is turned off. Vehicles equipped with A/C and the heated back glass system use a relay to regulate the A/C blower motor speed when the heated back glass system is in operation.

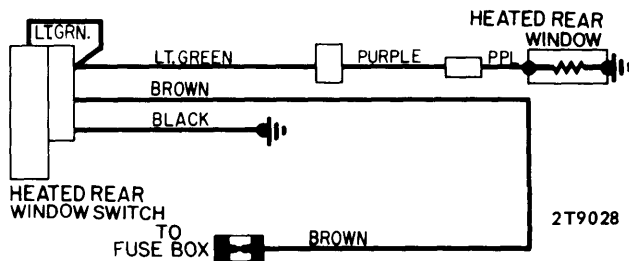

### PONTIAC HEATED REAR WINDOW

**Ford Motor Co. (Exc. Quick Defrost Unit)** – System is controlled by a three-position switch which is spring loaded to return from "ON" or "OFF" to its center or "NORMAL" position. When switch is turned to "ON", a relay is energized and delivers current to grid wires in back glass. Relay is called a latching relay because it remains latched in energized position until either control switch or ignition switch is turned off.

**Ford Motor Co. Quick Defrost Unit** – A relay timer and switch provide automatic control of system. Switch positions are "OFF", "NORMAL", "ON". The "ON" and "OFF" positions are spring loaded and return to "NORMAL" when released. An indicator light will glow when system is operating. When unit is turned on, current flows through timer to system's alternator field; alternator then transmits about 120 volt current to front and rear glass. The timer limits high voltage current to glass for about ten minutes; then automatically cuts output to low voltage. This is accomplished by a 2.2 ohm resistor being inserted in field current by timer. The engine must be operated at 1500 RPM for alternator to deliver high voltage. See *Motorcraft High Voltage Alternator* in **ELECTRICAL** Section.

## TESTING

### AMERICAN MOTORS

**Control Switch** – Disconnect the brown and brown with tracer wires from the switch. With an ohmmeter connected across the switch terminals and the switch in the OFF position, the meter should indicate 200 ohms resistance. When the switch is depressed and held in the ON position, the meter should indicate no resistance.

**Relay** – Disconnect three wire plug from relay. Connect a jumper wire from the accessory terminal of the fuse panel to the "X" terminal on the relay. Connect another jumper wire from the accessory terminal of the fuse panel to the brown terminal of the switch. Connect a third jumper wire from the brown with tracer terminal of the switch to the "P" terminal of the relay. Connect a 12 volt test lamp from the "L" terminal to a good ground. Turn ignition switch to accessory position. The test lamp should not light. Depress the defogger switch, test lamp should light and remain on for 3 to 7 minutes.

### CHRYSLER CORP.

**Control Switch** – With switch in "NORMAL" position, continuity should exist between two terminals. When "ON", continuity should exist between all terminals; when "OFF", there should be no continuity between terminals.

**Timer Relay** – Ground relay case and connect a jumper between terminals "X" and "Y" (see illustration). Connect a test light between "L" and ground; then apply a 12 volt power source to terminal "X" and test light should not light. If test light indicates power between "L" and ground, replace relay. Momentarily short "X" and "P" terminals; test light should come on and stay on for 3 to 7 minutes.

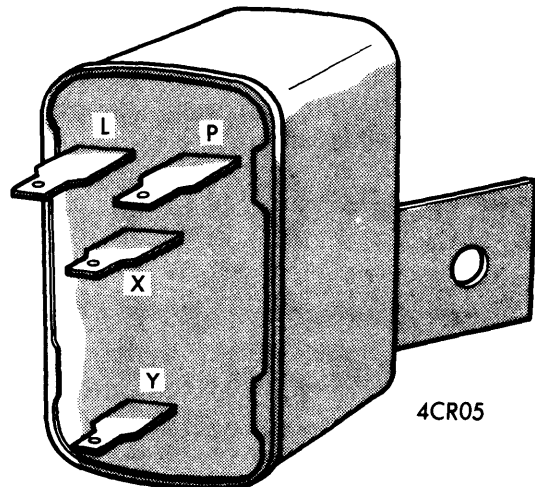

### CHRYSLER CORP. TIME DELAY RELAY

### FORD MOTOR CO. (EXC. QUICK DEFROST UNIT)

**Control Switch** – With switch in "NORMAL" position, continuity should exist between two terminals. In "ON" position, there should be continuity between all terminals. In "OFF" position, there should be no continuity between any terminals.

**Latching Relay** – Ground relay case, and connect a jumper wire between pins 1 and 2. Connect a 12 volt test light between pin 3 and ground. Apply power to pin 2. The test light should not light. Momentarily short pins 2 and 4, the test light should come on and stay on after the short is removed.

## 1974 ALL MODELS (Cont.)

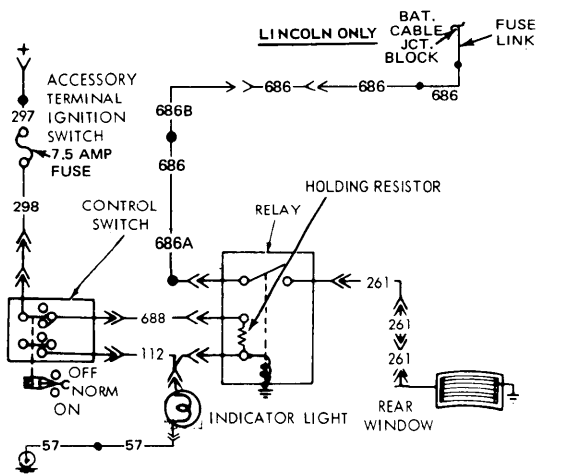

4FO03

LINCOLN LATCHING RELAY CIRCUIT

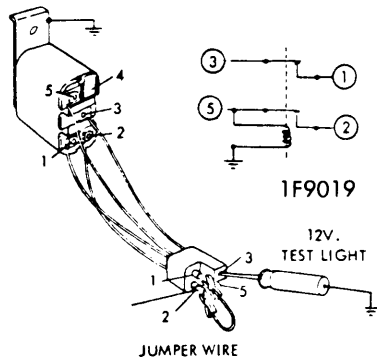

LATCHING RELAY TEST

**Relay Location** – Ford, Mercury, meteor; on bracket under lower edge of instrument panel left side. Cougar, Torino, Montego; on bracket behind instrument panel left side above headlight switch. The instrument panel pad must be removed for access to relay. Pinto; relay is mounted on instrument panel above glove box. Mustang; relay is located left of glove box on lower reinforcement panel. Thunderbird and Mark IV; located on bracket beside glove box. Lincoln; relay is mounted to bracket on left hand side in trunk.

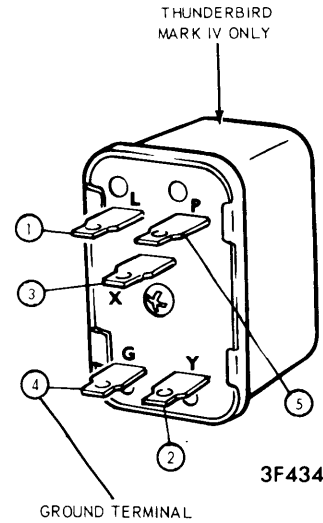

3F434

THUNDERBIRD & MARK IV RELAY

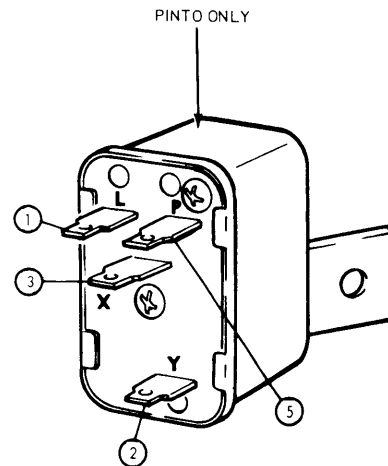

3F435

PINTO RELAY

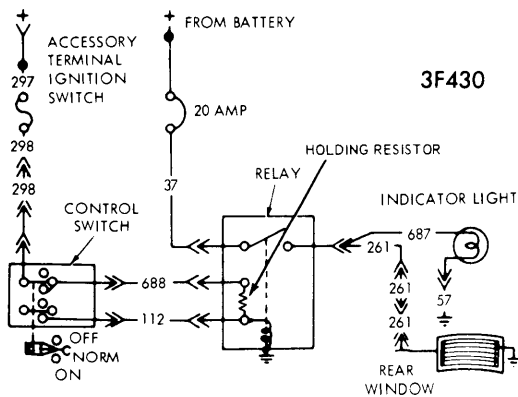

3F430

LATCHING RELAY CIRCUIT (EXC. LINCOLN)

### FORD MOTOR CO. QUICK DEFROST UNIT

**NOTE** – Manufacturer recommends that all repairs to high voltage alternator system must be made by Ford and Lincoln Mercury service departments. See Motorcraft High Voltage Alternator in ELECTRICAL Section.

**Preliminary Checks** – If system appears to malfunction, check supplemental alternator drive belt tension. Check alternator connections, check wire connectors at windshield and back glass. Connectors at rear of right front fender apron must be firmly connected. Start engine and turn control switch to "ON" position; check indicator light. Allow system to operate about four minutes at 1500 engine RPM; touch glass on both sides to verify system operation.

**System Does Not Turn "ON"** – 1) Check No. 1 terminal power at relay panel with timer removed (see illustration). With power available, see step 2). No power, check for power at load side of 30 amp. window heater fuse; no power, replace fuse; with power, locate and repair open circuit No. 37 YELLOW wire.

# Electric Window Defoggers

## 1974 ALL MODELS (Cont.)

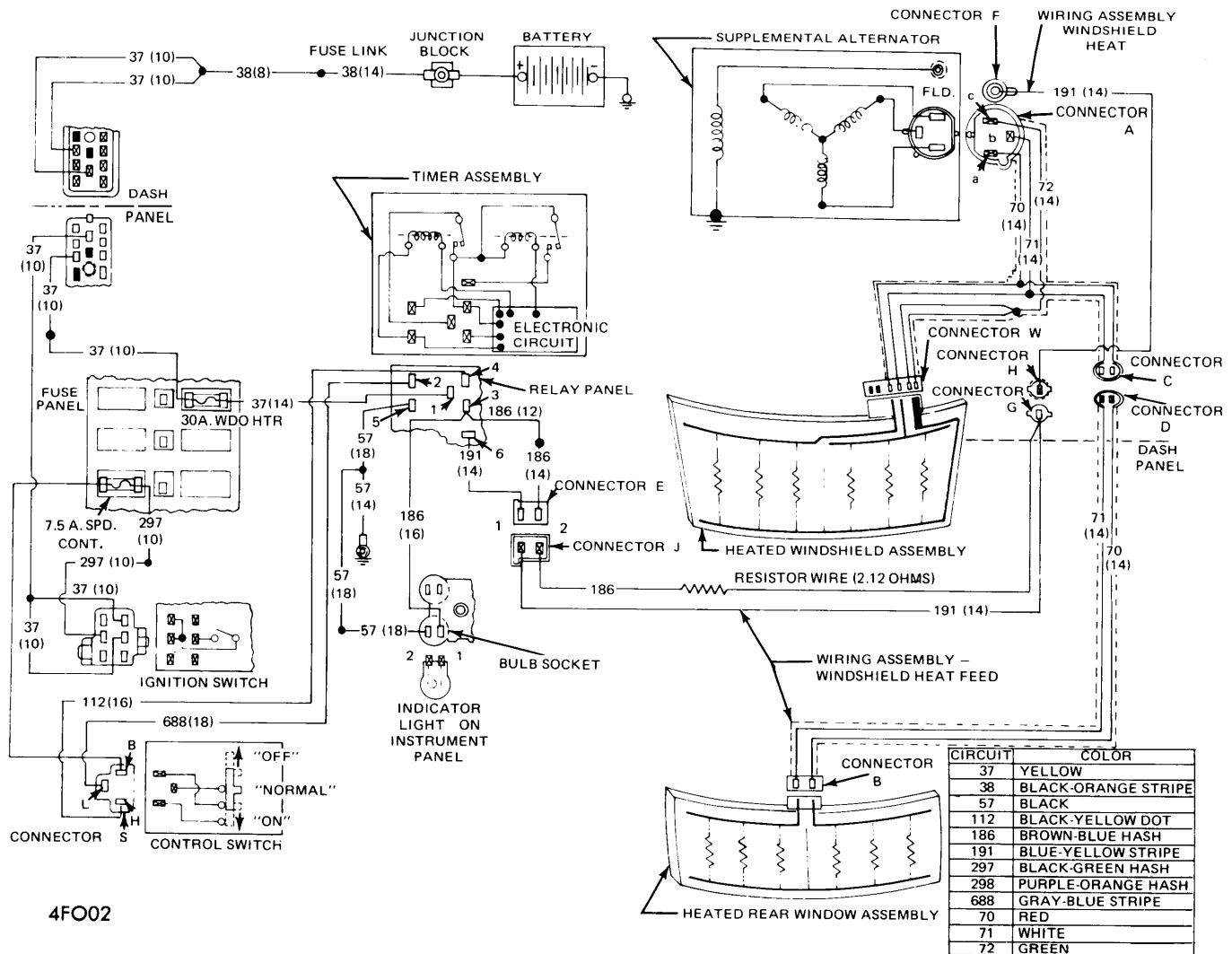

4FO02

### THUNDERBIRD & MARK IV QUICK DEFROST SYSTEM WIRING

2) Check relay panel No. 2 terminal power with switch in "NORMAL" position. Power available, see step 3). No power, check for power at "L" terminal connector of control switch in "NORMAL" position. Power available, repair open circuit No. 688 GRAY-LT. BLUE wire. No power, check for power at load side of 7.5 amp. speed control windshield washer fuse. No power, replace fuse; with power, locate and repair open circuit No. 298 PURPLE-ORANGE wire.

3) Check No. 4 terminal power at relay panel with switch held "ON". Power available, see step 4). No power, check for power at terminal "H" of control switch connector with switch held "ON". No power, replace switch; with power, locate and repair open circuit No. 112 BLACK-YELLOW wire.

4) Check relay panel No. 5 terminal for ground. No ground, repair open ground circuit. With a good ground, check relay panel No. 3 terminal for power with switch held "ON", and timer installed. No power, replace timer.

**System Will Not Turn "OFF"** - 1) Check for power at terminal No. 4 on relay panel with switch in "NORMAL" position and timer installed. No power, see step 2). With power available, disconnect switch and check relay panel No. 4 terminal power. With no power, replace switch. With power, repair crossed or shorted circuit No. 112 BLACK-YELLOW wire.

2) Check relay panel No. 2 terminal power with switch held in "OFF" position. No power, replace timer; with power, disconnect switch and check relay panel No. 2 terminal power again; no power, replace timer, with power, repair crossed or shorted circuit No. 688 GRAY-LT. BLUE wire.

**Indicator Light Does Not Illuminate, But Glass Heats** - Check terminal No. 1 power for light socket with switch held "ON". If power is available, check ground at terminal No. 2 and check light continuity. If power is not available at terminal No. 1, check for power of relay panel No. 3 terminal with switch held "ON" and timer installed. No power, replace timer; with power, repair open circuit to light socket (circuit No. 186 BROWN-LT. BLUE wire).

**Indicator Light Comes On, Glass Does Not Heat** - Check connector "F" (see illustration) power at alternator. No power, check for power at relay panel No. 3 terminal with timer installed. Power available, locate and repair open circuit to field. No power at terminal No. 3; locate and repair crossed or shorted circuit No. 186 BROWN-LT. BLUE wire to indicator light. If power was available at connector "F", check continuity of circuits No. 70 RED, No. 71 WHITE and No. 72 DK. GREEN wires (all wires disconnected). If wires are good, check alternator. See *Motorcraft High Voltage Alternator* in *ELECTRICAL Section*.