

1966-74 MOTORCRAFT (AUTOLITE) POSITIVE ENGAGEMENT

DESCRIPTION

Four pole, four brush starter with three series of coils and one shunt coil. Shunt coil is wound around a movable pole piece which operates the integral positive engagement drive mechanism.

TESTING

Starter Cranking Circuit Test – Make test connections as shown in illustration. Crank engine with ignition off (disconnect and ground high tension lead from coil and connect jumper from battery terminal of starter relay to "S" terminal of relay). Maximum allowable voltage drop should be as follows:

- 1) With voltmeter negative lead connected to starter terminal and positive lead connected to battery positive terminal (connection 1), voltage drop should not exceed .5 volt.
- 2) With voltmeter negative lead connected to battery terminal of starter relay and positive lead connected to battery positive terminal (connection 2), voltage drop should not exceed .1 volt.
- 3) With voltmeter negative lead connected to starter terminal of starter relay and positive lead connected to battery positive terminal (connection 3), voltage drop should not exceed .3 volt.
- 4) With voltmeter negative lead connected to negative terminal of battery and positive lead connected to engine ground (connection 4), voltage drop should not exceed .1 volt.

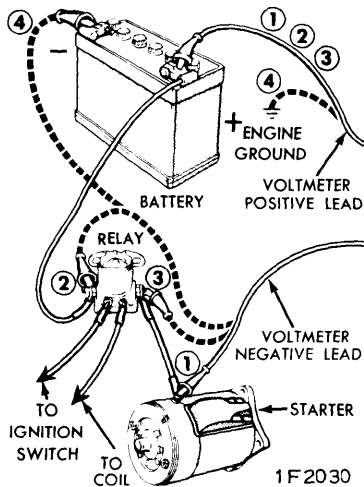

CRANKING CIRCUIT TEST CONNECTIONS

Starter Load Test – Make test connections as shown in illustration. *NOTE – Make sure no current is flowing through ammeter and rheostat is at maximum counterclockwise position.* Crank engine with ignition off (disconnect and ground coil high tension lead and connect jumper from battery terminal of starter relay to ignition switch terminal of relay). Note voltmeter reading. Stop cranking engine, reduce resistance of carbon pile until voltmeter indicates same reading as when cranking. Ammeter now indicates current draw under load.

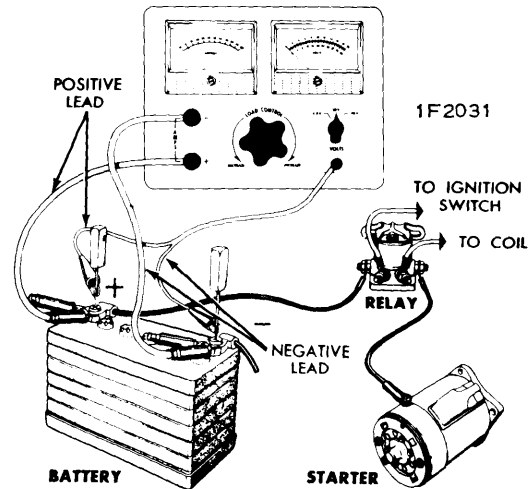

STARTER LOAD TEST CONNECTIONS

Starter No-Load Test – Make test connections as shown in illustration. *NOTE – Make sure no current is flowing through ammeter (rheostat at maximum counterclockwise position).* Note exact reading on voltmeter. Disconnect starter from battery and reduce resistance of rheostat until voltmeter indicates same reading as when starter was running. Ammeter will indicate starter no-load current draw.

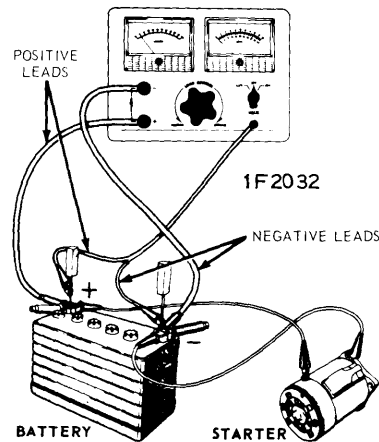

STARTER NO-LOAD TEST CONNECTIONS

Armature – Check armature for shorted coils with a growler. Test for grounded coils with a test lamp or voltmeter and battery connected in series, by touching one test probe to commutator and other test probe to core or armature shaft. If test lamp lights, or voltmeter shows any reading, coils are grounded. Commutator should be clean and smooth. If commutator burned, or out-of-round more than .005", turn down in a lathe and sand lightly with 00 sandpaper.

Field Coil – Check for open or grounded coils with test lamp or voltmeter and battery connected in series. Make sure insulated brush leads are clear of frame, block drive coil contacts (on frame) open by inserting insulator between contacts, disconnect holding coil ground lead from frame. Touch one test probe to coil lead, other probe to

1966-74 MOTORCRAFT (AUTOLITE) POSITIVE ENGAGEMENT (Cont.)

frame. If lamp lights or voltmeter shown any reading, coils are grounded. Test for open coils by placing one test probe to field terminal and other probe to insulated brush lead. Lamp should light or voltmeter should show reading.

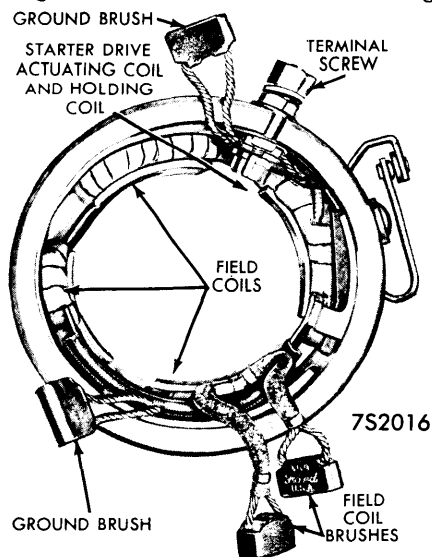

FIELD COIL ASSEMBLY

Brushes & Springs – Check brush holders for broken springs and insulated brush holders for shorts to ground. Tighten any loose rivets. Replace brushes if worn to ¼" in length.

SPECIFICATIONS

Cranking Amperage Draw – 150-200 amperes with a normal cranking speed of 180-250 RPM (4" diameter starter). The 4½" diameter starter should draw 150-180 amperes with a normal cranking speed of 150-290 RPM.

Brush Spring Tension – 40 ozs. (4" diameter starter). The 4½" diameter starter should have 80 ozs.

Rotation – Clockwise at drive end.

POSITIVE ENGAGEMENT SPECIFICATIONS				
Dia. (Inches)	Normal Draw (Amps)	Normal Speed (RPM)	Max. Load (Amps)	No Load (Amps)
4	150-200	180-250	460	70
4½	150-180	150-290	670	① 70

① – 1974, 80 Amps.

OVERHAUL

DISASSEMBLY

1) Remove brush cover band and starter drive lever cover. Remove brushes from brush holders (note lead positions for assembly). Remove through bolts, starter drive end housing and starter drive plunger lever return spring. Remove actuating lever pivot pin. Remove lever and slide armature out.

2) Remove stop ring retainer. Remove and discard stop ring retaining starter drive gear to end of armature shaft, then remove starter drive gear assembly. Remove brush end plate. Remove screws retaining ground brushes to frame. Bend tab up on field coil (which operates drive gear actuating lever) retaining sleeve, remove sleeve.

3) Remove coil retaining screws. Unsolder field coil leads from terminal screw, remove pole shoes and coils from frame. Unsolder insulated brush leads from field coils. Remove starter terminal nut, washer, insulator and terminal from starter frame.

CLEANING

Use a brush or air to clean field coils, armature, commutator and armature shaft, front end plate and rear end housing. Wash other parts in solvent and dry with air.

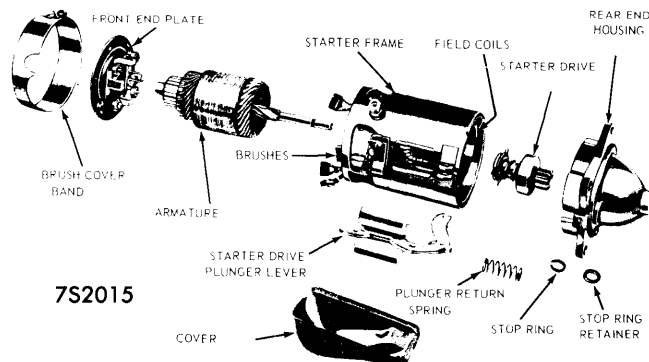

FORD MOTOR CO. POSITIVE ENGAGEMENT STARTER ASSEMBLY

REASSEMBLY

1) Install starter terminal, insulator, washers and retaining nut. *NOTE* – Position slot in screw perpendicular to frame end surface. Position coils and pole pieces (with coil leads in terminal screw slot), install retaining screws. As screws are tightened, strike frame several sharp blows with soft-faced hammer to seat and align pole shoes, then stake screws.

2) Install solenoid coil and retainer and bend tabs to retain coils to frame. Solder field coils and solenoid wire to starter terminal using rosin core solder. Check for continuity and grounds in assembled coils. Position new insulated brush leads on field coil terminal (use clip provided with brushes to hold brush lead to terminal), solder lead, clip, and terminal with rosin core solder.

3) Position solenoid coil ground terminal on nearest ground screw hole, position both ground brushes and install attaching screws. Position commutator end plate on frame with end plate boss in frame slot. Apply thin coating of lubriplate on armature shaft splines, install drive assembly on shaft, then install new stop ring and retainer. Position fiber thrust washer on commutator end of armature and position armature in starter frame.

4) Position starter drive gear plunger lever to frame and starter drive assembly, install pivot pin. Partially fill drive end housing (approximately ¼ full) bearing bore with grease. Position drive plunger lever return spring and drive end housing to frame, install and tighten through bolts to 55-75 inch Lbs. *CAUTION* – Do not pinch brush leads between plate and frame. Make sure stop ring retainer is seated properly in drive housing.

5) Install brushes in brush holders, centering springs on brushes. Position drive gear plunger lever cover on starter and install brush cover band with a gasket. Tighten band retaining screw. Check starter no-load current draw.