

DELCO-REMY ENCLOSED HOUSING

Description

12 volt, 4 pole starters of conventional design. Starters have solenoid pinion shift (overrunning clutch) with entire shift mechanism enclosed within drive housing. Field assembly consists of four series coils or combination of series coils with one or two shunt coils. Brush assemblies are completely enclosed within field frame at commutator end so that entire starter and drive assembly is protected from dirt and splash.

Performance Tests

Free Running (No Load) Test - Connect an ammeter and carbon pile rheostat in series with battery to solenoid "BAT" terminal. Connect a voltmeter across starter and a tachometer to indicate starter armature RPM. Energize starter by connecting other battery terminal to starter frame. Adjust rheostat to give specified voltage on voltmeter and note ammeter and tachometer readings. Current draw and starter RPM should be as specified. See Specifications.

Lock Test - With ammeter and voltmeter connected as for Free Running Test (above), lock armature so that it cannot turn. Adjust rheostat for specified voltage. Current draw should be as specified. See Specifications.

Specifications

Brush Spring Tension - 35 ozs.

Rotation - Clockwise at pinion end.

Pinion-to-Housing Clearance - .010-.140" between pinion and pinion stop with pinion in engaged position.

OVERHAUL

Disassembly

1) Disconnect field lead strap from solenoid by taking out terminal screw. Remove two through bolts, withdraw commutator end frame and field frame by pulling these parts off the armature. Remove thrust washer from commutator end of armature shaft.

2) Pull out brush holder pivot pin and remove two brush holders and spring as an assembly. Remove brushes by taking out screws attaching brushes and leads to holder.

3) Remove two solenoid attaching screws and remove solenoid from drive housing. To remove solenoid cover for switch inspection, remove nuts and insulating washers from solenoid "S" and "BAT" terminals, remove cover.

4) Remove shift lever fulcrum bolt, remove shift lever, plunger, and return spring from end housing. Withdraw armature assembly. Remove thrust collar from pinion end of armature shaft.

5) To remove drive assembly from armature shaft, install piece of correct size tubing over end of shaft and against pinion stop retainer, tap retainer toward armature to uncover snap ring. Remove snap ring from groove in shaft, then slide retainer and drive assembly off shaft.

Cleaning

Clean all parts by wiping with clean cloths. Do not clean armature, field coils, or drive assembly in any type of grease dissolving solvent (will damage insulation and wash lubricant out of drive assembly).

Parts Replacement & Testing

Armature - Test armature for shorted coils with a growler. Check for grounded coils with a 110 volt test lamp. Place one test lead on armature core or shaft, and other test lead on commutator. Lamp should not light. If lamp lights, armature is grounded and should be replaced. Inspect

commutator. If commutator worn, out-of-round, or has high insulation, turn down commutator in a lathe, undercut insulation 1/32" deep and square across entire width, sand commutator lightly with 00 sandpaper and clean out slots carefully.

► **CAUTION** - Some starters have molded type commutator and insulation must not be undercut on these models (may cause serious damage to commutator).

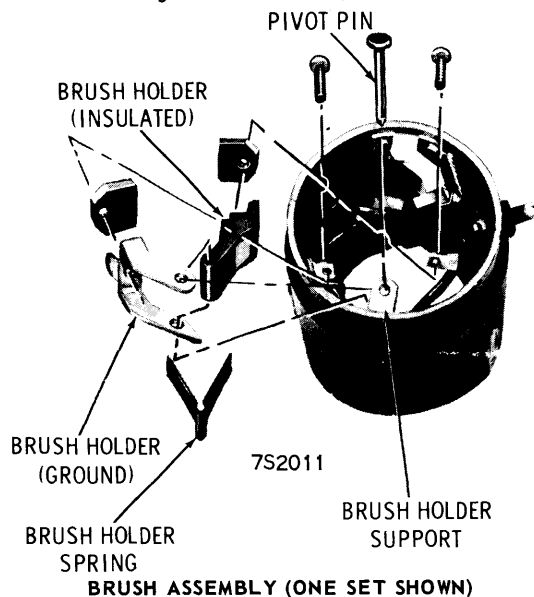

Field Coils - Check with 110 volt test light. Place one test lead on field coil terminal strap, touch other test lead to field coil brush lead (check series coils and shunt coils separately at appropriate terminals). Lamp should light. If lamp does not light, coils are open. Check for grounds by placing one test lead on field terminal strap, touch other test lead to armature core or shaft. (CAUTION - Shunt coil ground lead must be disconnected and all field terminals insulated from frame when making this test). If lamp lights, one or more coils are grounded.

Brushes, Springs, & Holders - Replace brushes if worn to one-half original length, or if oil-soaked or pitted. Check brush spring tension and replace springs if weak or distorted. Deformed or bent brush holders can be replaced by service units which are installed with screws and nuts.

Drive & Pinion Assembly - Pinion should turn freely in overrun direction and should not slip in drive direction. Check spring for correct tension and drive collar for wear (these parts can be removed for replacement by forcing collar toward clutch and removing lock ring from end of tube). Replace drive assembly if pinion teeth worn, chipped, or cracked.

Armature Shaft Bushings - Inspect armature shaft bearing surfaces and check for wear by noting sideplay with shaft inserted in bushings. Drive end bushing can be replaced. Replace commutator end plate assembly if bushing worn.

Solenoid & Pinion Shift Mechanism - For testing and adjustment, see "Delco-Remy Enclosed Housing Starter Controls".

Reassembly

1) Lubricate armature shaft with silicone lubricant or few drops of SAE 10 engine oil, install drive assembly on shaft, install retainer with cupped side out or away from pinion, install lock ring in shaft groove, install thrust collar with shoulder against lock ring. Position retainer

DELCO-REMY ENCLOSED HOUSING (Continued)

on lock ring by using two pliers at opposite points to squeeze retainer and thrust collar together against lock ring.

2) Assemble brush holders and install brushes, connect field leads to proper brushes, check assemblies for free movement.

3) Assemble solenoid plunger on shift lever. Lubricate drive housing bushing with silicone lubricant or few drops of SAE 10 engine oil. Install armature and drive assembly in drive housing with shift lever engaged in drive collar, install shift lever pin. Coat both sides of solenoid flange with suitable sealer (No. 1050026), place return spring over plunger and install solenoid, tighten solenoid attaching screws securely.

4) Align field frame dowel with dowel hole in drive housing, install field frame over armature and against end housing (CAUTION - Lift brushes up over commutator as field frame installed to prevent damage to brushes).

5) Install thrust washer (leather brake washer) on end of armature shaft. Lubricate commutator end frame bushing with silicone lubricant or few drops of SAE 10 engine oil, install end frame, install through bolts and tighten securely.

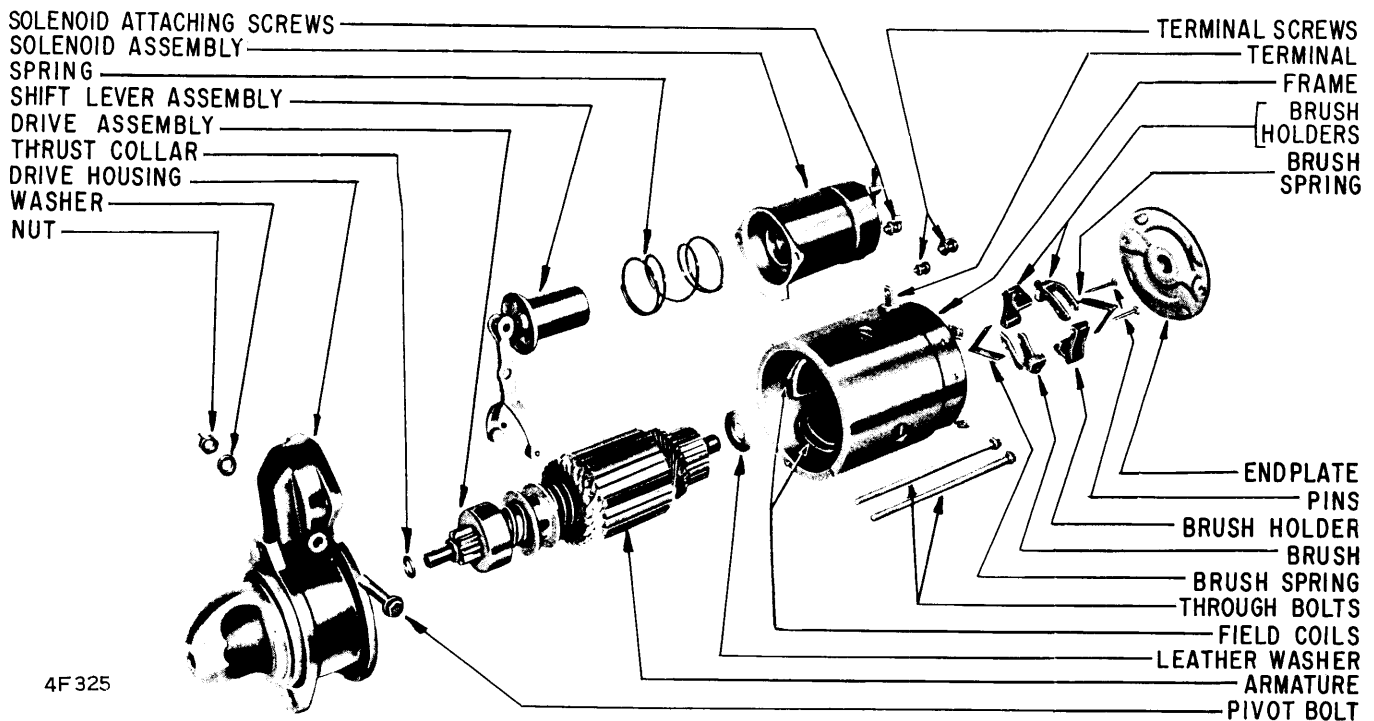
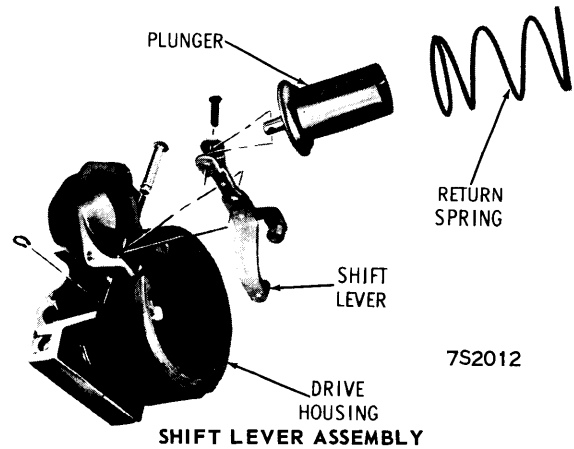

DELCO-REMY ENCLOSED HOUSING STARTER ASSEMBLY

Starters

DELCO-REMY ENCLOSED HOUSING

1971 DELCO-REMY STARTER SPECIFICATIONS			
Delco-Remy Number	No Load Test		
	Amps. ①	RPM	Volts
1108352	45-80	4000-6500	9
1108365	50-80	5500-10500	9
1108367	50-80	5500-10500	9
1108371	65-95	7500-10500	9
1108386	55-80	3500-6000	9
1108387	45-80	4000-6500	9
1108389	65-95	7500-10500	9
1108391	55-80	3500-6000	9
1108392	45-80	4000-6500	9
1108400	65-95	7500-10500	9
1108418	65-95	7500-10500	9
1108425	40-105	3500-6500	9
1108429	65-95	7500-10500	9
1108430	65-95	7500-10500	9
1108436	65-95	7500-10500	9
1108445	55-80	3500-6000	9
1108446	65-95	7500-10500	9

① — Includes solenoid

1972 DELCO-REMY STARTER SPECIFICATIONS			
Delco-Remy Number	No Load Test		
	Amps. ①	RPM	Volts
1108195	50-75	6500-10000	9
1108196	50-75	6500-10000	9
1108352	65-95	7500-10500	9
1108365	50-80	5500-10500	9
1108366	50-80	5500-10500	9
1108367	50-80	5500-10500	9
1108381	95-65	7500-10500	9
1108386	55-80	3500-6000	9
1108387	45-80	4000-6500	9
1108391	55-80	3500-6000	9
1108392	45-80	4000-6500	9
1108400	65-95	7500-10500	9
1108418	65-95	7500-10500	9
1108425	40-105	3500-6500	9
1108429	65-95	7500-10500	9
1108430	65-95	7500-10500	9
1108436	65-95	7500-10500	9
1108445	55-80	3500-6000	9
1108446	65-95	7500-10500	9

① — Includes solenoid

1973 DELCO-REMY STARTER SPECIFICATIONS			
Delco-Remy Number	No Load Test		
	Amps. ①	RPM	Volts
1108195	50-75	6,500-10,000	9
1108352	65-95	7,500-10,500	9
1108365	50-80	5,500-10,500	9
1108366	50-80	5,500-10,500	9
1108367	50-80	5,500-10,500	9
1108371	65-95	7,500-10,500	9
1108386	55-80	3,500-6,000	9
1108387	45-80	4,000-6,500	9
1108389	65-95	7,500-10,500	9
1108400	65-95	7,500-10,500	9
1108418	65-95	7,500-10,500	9
1108430	65-95	7,500-10,500	9
1108495	50-80	5,500-10,500	9
1108498	55-80	3,500-6,000	9
1108500	37-75	6,000-9,000	9
1108503	55-80	3,500-6,000	9
1108504	45-80	4,000-6,500	9

① — Includes solenoid

1974 DELCO-REMY STARTER SPECIFICATIONS			
Delco-Remy Number	No Load Test		
	Amps. ①	RPM	Volts
1108195	50-75	6,500-10,000	9
1108196	50-75	6,500-10,000	9
1108224	65-95	7,500-10,000	9
1108225	37-75	6,000-9,000	9
1108226	37-75	6,000-9,000	9
1108365	50-80	5,500-10,500	9
1108400	65-95	7,500-10,500	9
1108418	65-95	7,500-10,500	9
1108429	65-95	7,500-10,500	9
1108430	65-95	7,500-10,500	9
1108436	65-95	7,500-10,500	9
1108498	55-80	3,500-6,000	9
1108500	37-75	6,000-9,000	9
1108506	55-80	3,500-6,000	9
1108507	45-80	4,000-6,000	9
1108516	55-80	3,500-6,000	9
1108517	45-80	4,000-6,000	9
1108518	65-95	7,500-10,000	9
1108521	65-95	7,500-10,000	9
1108522	65-95	7,500-10,000	9

① — Includes solenoid