

## FORD MOTOR CO. DOUBLE CONTACT

### ► CHANGES, CAUTIONS, CORRECTIONS

► **SERVICE PRECAUTIONS:** When testing or servicing alternator or regulator, take the following precautions to avoid damage to components:

**Alternator** - DO NOT ground field circuit between alternator and regulator nor operate alternator on an open circuit with field winding energized. DO NOT ground output terminal. ALWAYS disconnect battery negative cable before removing wire from alternator output terminal. Do not attempt to polarize alternator as polarization is not required and any attempt to polarize will damage voltage regulator and wiring harness.

**Regulator** - Turn ignition switch off when working on regulator. Use care to prevent a short circuit between voltage regulator relay and regulator base when working on regulator. Use an insulated tool when making adjustments.

► **CONTINENTAL MARK III NOTE:** Regulator is solid state hybrid unit mounted on alternator. Regulator can be removed from alternator but is not serviceable and must be replaced if malfunctioning.

► **1968-69 NOTE (ALL CARS):** The regulator is factory calibrated and is not to be adjusted or disassembled.

### 1967-68 Regulator Identification

Identified by stamp color on regulator as follows: SILVER (38 & 42 Ampere Alternators), YELLOW (45, 55 & 65 Ampere Alternators).

### 1969 Regulator Identification

Regulator identified by number as follows: No. C8AF-A (38 & 42 Ampere Alternators), No. C8TF-A (55 & 65 Ampere Alternators).

### DESCRIPTION

Regulator consists of a relay for field excitation which closes when voltage supplied by neutral terminal of alternator is sufficient to operate relay armature. A double contact voltage regulator which is temperature compensated, controls amount of current supplied to rotating field. With upper contacts closed, full system voltage is supplied to field, and with lower contacts closed, no current flows to field. A resistor in regulator reduces field current when armature floats between each set of contacts.

### TESTING

#### Field Relay

Remove regulator cover and connect a carbon pile rheostat from battery positive post to regulator "S" terminal. Connect battery negative post to regulator base. Connect a voltmeter from regulator "S" terminal to regulator base. Slowly rotate resistance control so relay contacts close. Note voltmeter reading at the moment contacts close. This is relay closing voltage and should be 2.5-4 volts. If relay closes immediately, even with field resistance out of circuit, use a 6-volt battery and retest. If field relay closing voltage is not within limits, bend relay frame (spring arm) down to increase voltage, and up to decrease voltage.

#### Voltage Regulator

**NOTE** - For testing, lower stage (armature vibrating on lower contacts) regulation is used. Calibration tests must be made with regulator cover in place and with regulator at normal operating temperature (temperature after 20 minutes operation on car with a 10 ampere load). Connect tester as indicated in illustration, then turn off all accessories and lights. Close battery adapter switch, start engine, then open adapter switch. Attach a suitable thermometer to regulator cover and operate engine at 2000 RPM for 5 minutes. Turn master control on tester to DIRECT position. If ammeter indicated more than 10 amperes, stop engine and charge battery. With battery fully charged and regulator stabilized, rotate control on tester to VOLTAGE REG. position. The ammeter should indicate less than 2 amperes. Cycle the regulator as follows: Stop engine, close adapter switch, start engine, and open adapter switch. Allow battery to normalize for a short time, then check voltmeter reading and temperature. Voltage should be within limits indicated in specifications for the specified temperature. If regulator is not within limits, make adjustments as outlined under "Adjustment" below. **NOTE** - After each adjustment, be sure to cycle regulator before each reading. Reading must be made with cover in place.

### ADJUSTMENT

#### Field Relay (1963-64)

**Cut-In (Closing) Voltage** - To adjust, bend spring arm at lower end of coil spring down to increase voltage and up to decrease voltage.

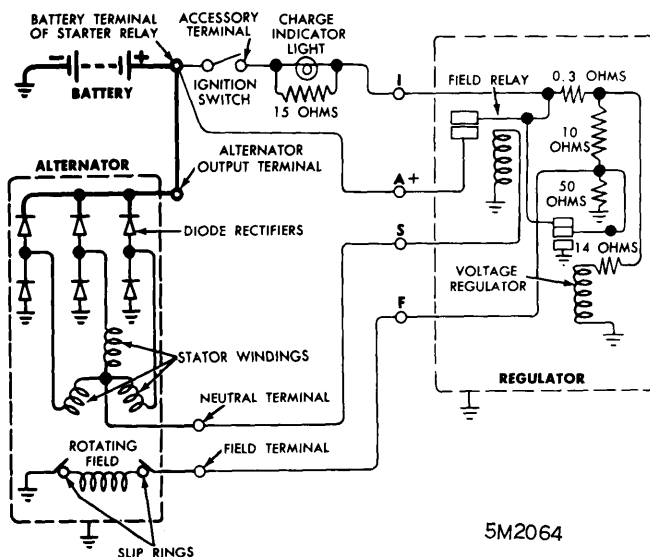

INTERNAL CIRCUITS (WITH CHARGE INDICATOR LIGHT)

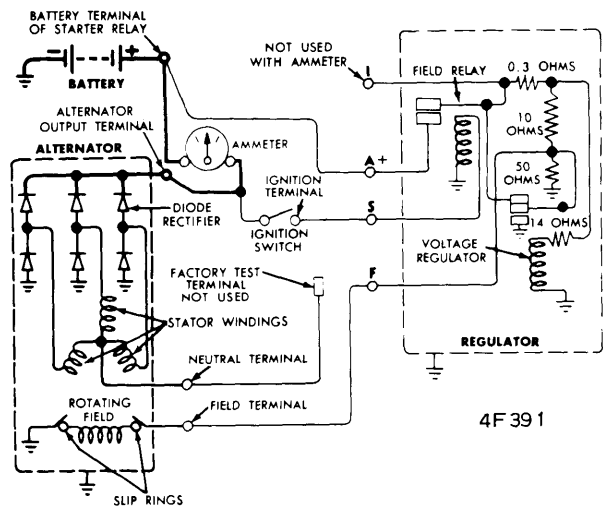

INTERNAL CIRCUITS (WITH AMMETER)

## FORD MOTOR CO. DOUBLE CONTACT (Continued)

**Point Gap** - Loosen lock screw 1/4-turn and insert a screwdriver in adjustment slot above screw to move armature stop up or down.

**Air Gap** - Loosen center lock screw 1/4-turn and insert a screwdriver in adjustment slot below screw to move contact bracket up or down.

### Field Relay (1965-69)

**Cut-In (Closing) Voltage** - To adjust, bend spring arm at lower end of coil spring down to increase voltage and up to decrease voltage.

**Air Gap** - Loosen center lock screw 1/4-turn and insert a screwdriver in adjustment slot below screw to move contact bracket up or down.

### Voltage Regulator

**Voltage Setting** - Adjust by bending spring arm at lower end of spring down to increase voltage, up to decrease voltage.

**Point Gap (Lower Contacts)** - With upper contacts closed, loosen lock screw 1/4-turn and insert a screwdriver in adjustment slot above screw to move armature stop up or down.

**Air Gap** - With upper contacts closed, loosen center lock screw 1/4-turn and insert a screwdriver in adjustment slot below screw to move contact up or down.

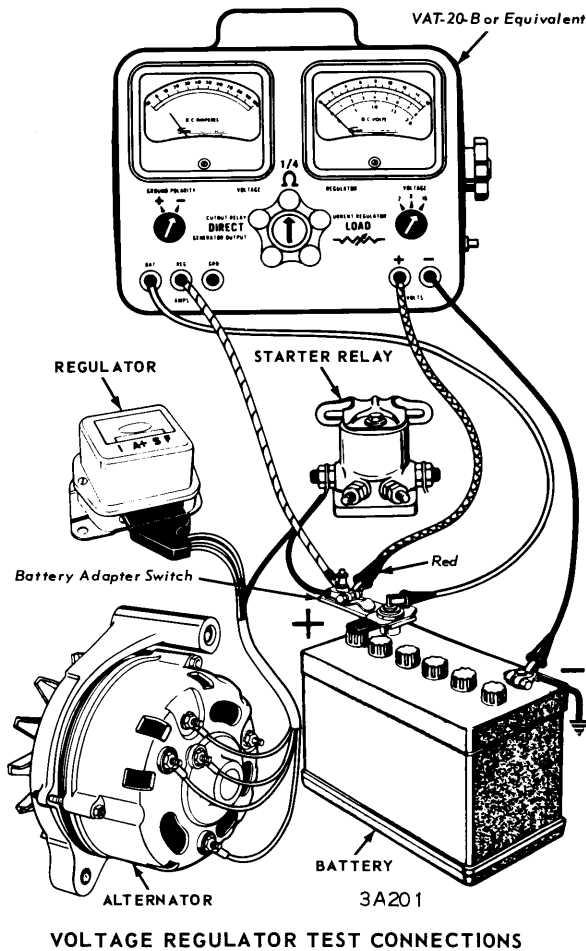

### Field Relay Specifications

Year	Closing Voltage	Air Gap
1963	2.5-4.0 volts	.022-.030"
1964	2.5-4.0 volts	.015-.025"
1965-67	2.5-4.0 volts	.010-.018" (.012" Preferred)
1968	2.0-4.2 volts	
1969	2.3-4.2 volts	

### Voltage Regulator Specifications

Year	Point Gap	Air Gap
1963	.010-.015"	.045-.052"
1964-67	.017-.022"	.049-.056"
1968-69	Not Available	Not Available

### Voltage Setting Specifications (Except 1967 Models)

Ambient Temp.	Setting (Volts)	Ambient Temp.	Setting (Volts)
50° F	14.3-15.1	125° F	13.8-14.6
75° F	14.1-14.9	150° F	13.6-14.4
100° F	13.9-14.7	175° F	13.5-14.3

### Voltage Setting Specifications (1967-69 Models)

Ambient Temp.	Setting (Volts)	Ambient Temp.	Setting (Volts)
50° F	14.1-15.1	125° F	13.6-14.6
75° F	13.9-14.9	150° F	13.4-14.4
100° F	13.7-14.7	175° F	13.3-14.3