

Alternator Regulators

ESSEX REGULATOR (CHRYSLER CORP.)

Chrysler No. 2444980 (All Models)

Description

Field control type. Temperature compensated, vibrating type voltage regulator with two sets of contacts using a common armature. The common upper and lower stationary contacts are mounted on a bracket which is attached to, but insulated from the regulator frame. The lower contact mounted on the armature is connected to the "IGN" terminal. The upper contact, mounted on the armature, but insulated from it, is connected to ground by a flexible wire. The stationary contacts are connected to the "FLD" terminal by a fusible link. Regulator operates on either upper or lower contacts (both sets never in operation at the same time) depending on load and battery requirements as follows:

Lower Contact Operation (High Speed & Low Load) - Armature travel opens and closes lower contacts, cutting regulator resistance in and out of field circuit, and limiting alternator field current.

Upper Contact Operation (Low Speed & High Load) - Armature travel opens and closes upper contacts, grounding the regulator field terminal and bypassing alternator field coil (contacts closed), or cutting resistance in field (contacts open), limiting field current.

Checking Regulator

NOTE - Voltage regulator test is made with Tester VAT-20D. If other equipment is used in lieu of this Tester, follow manufacturer's instructions carefully.

When using Tester VAT-20D, regulator temperature should be normalized by operating with a 10 ampere load for 15 minutes. Set controls as follows:

- 1) Set Polarity Switch to NEGATIVE position.
- 2) Set Tester Control Knob to DIRECT position.
- 3) Set Voltage Switch to 2 VOLT position.
- 4) Set Field Control to OPEN position.

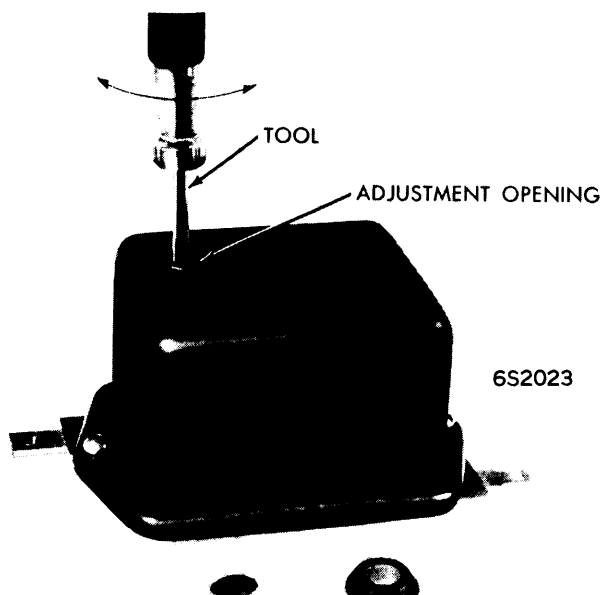

LOWER CONTACT VOLTAGE ADJUSTMENT

Tester Lead Connections - 1) Disconnect battery positive cable from battery post and install BATTERY POST ADAPTER between cable and post.

- 2) Connect "BAT" lead of Tester to stud on adapter.
- 3) Connect Tester "REG" lead to adapter binding post.
- 4) Connect Tester "GRD" lead to battery negative terminal.

NOTE - The BATTERY POST ADAPTER BY-PASS SWITCH must be open for all charging system tests. It is closed for starting the engine.

Lower Contacts Test - 1) With ignition switch turned off, disconnect field wire from "FLD" terminal of alternator.

- 2) Connect one of the test leads of Tester Field Control to "FLD" terminal of alternator.
- 3) Connect other lead of Tester Field Control to field wire disconnected from alternator "FLD" terminal.
- 4) Set Tester Voltage Switch to 16 VOLT position.
- 5) Connect positive lead of Tester Voltmeter to "BAT" terminal of alternator.
- 6) Connect negative lead of Tester Voltmeter to battery negative terminal.
- 7) Rotate Tester Field Control to the DIRECT position.
- 8) With engine operating at 1250 RPM, rotate Tester Control Knob clockwise until Ammeter reads exactly 15 amperes.

9) Rotate Tester Field Control from DIRECT position to OPEN position and then back to DIRECT position to cycle the system.

10) Observe Tester Voltmeter. Voltmeter now indicates setting of voltage regulator lower contacts. Refer to "Specifications".

11) Rotate Tester Control Knob to DIRECT position. If regulator operates within specifications, proceed to lower contact voltage test. If upper contact voltage setting is not within specifications, adjust voltage setting as outlined in "Regulator Adjustments" test number (1).

Upper Contacts Test - CAUTION - Be sure the negative post of battery is always connected to ground. Incorrect battery polarity may result in wiring harness damage and may damage alternator rectifiers. Do not ground alternator field circuit, as this may damage the regulator.

- 1) Increase engine speed to 2200 RPM.
- 2) Rotate Tester Control Knob to ¼ OHM position only if Tester Ammeter reads over 5 amperes.

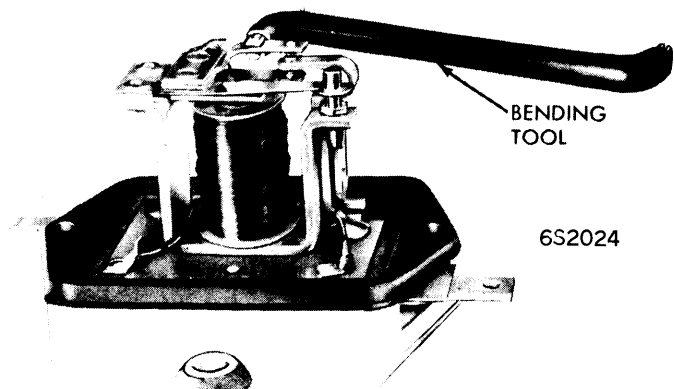

UPPER CONTACT VOLTAGE ADJUSTMENT
(UPPER CONTACT POINT GAP)

ESSEX REGULATOR (CHRYSLER CORP.) (Continued)

3) Rotate Tester Field Control from the DIRECT position to the OPEN position and then back to the DIRECT position to cycle the system.

4) Observe voltmeter. Voltmeter now indicates setting of the voltage regulator upper contacts. Refer to specifications.

Voltage should increase not less than .2 volt or more than .7 volt above previous operating voltage setting recorded in lower contact test. A voltage reading of less than .2 volt or more than .7 volt is an indication of a possible wrong air gap setting, refer to "Regulator Mechanical Adjustments".

5) Rotate Tester Field Control to OPEN position and Control Knob to DIRECT position. After tests completed, reduce engine speed to idle, disconnect all test leads and adapters. Restore all regular wiring connections.

► **AMBIENT TEMPERATURE NOTE:** The ambient temperature is the temperature registered on a reliable thermometer positioned 1/4" from regulator cover.

Voltage Setting - Ambient Temperature

Temp.	Volts	Temp.	Volts
47°F.....	13.6-14.6	117°F.....	13.3-14.3
70°F.....	13.5-14.5	140°F.....	13.2-14.2
93°F.....	13.4-14.4	163°F.....	13.1-14.1

Adjustment

Lower Contact Voltage Setting - Adjust lower contact voltage setting as necessary by turning the adjustment screw clockwise to increase voltage or counterclockwise to decrease voltage.

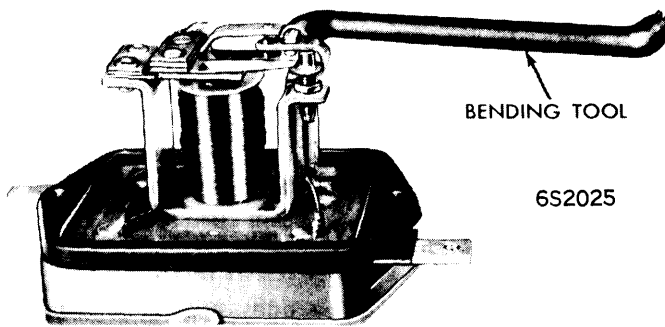

REGULATOR AIR GAP ADJUSTMENT

Upper Contact Voltage Setting - Measure upper contact point gap. Upper contact gap should be .014"±.004". Adjust upper contact gap as necessary by bending armature upper contact bracket, making sure contacts are in alignment.

Air Gap - .032"-.042". If upper contact gap is correct and voltage regulator setting is still outside the .2 to .7 volt increase, adjust air gap as follows:

If the difference is about .7 volt, reduce air gap by bending down the fixed contact bracket. If the difference is below .2 volt, increase air gap by bending fixed contact bracket up.

- 1) Connect a small dry cell test lamp in series with the "IGN" and "FLD" terminal of the voltage regulator.
- 2) Insert a .032" wire gauge between regulator armature and core of voltage coil next to stop pin on the armature, and press down on the armature until armature contacts wire gauge. Lower contacts should just open and test lamp should be dim. With air gap adjusted, it should not be possible to insert .042" wire gauge between armature and core.

Voltage Regulator Fusible Wire Replacement - Install a new fuse wire. Solder both ends of a new fuse wire securely using only resin core solder.

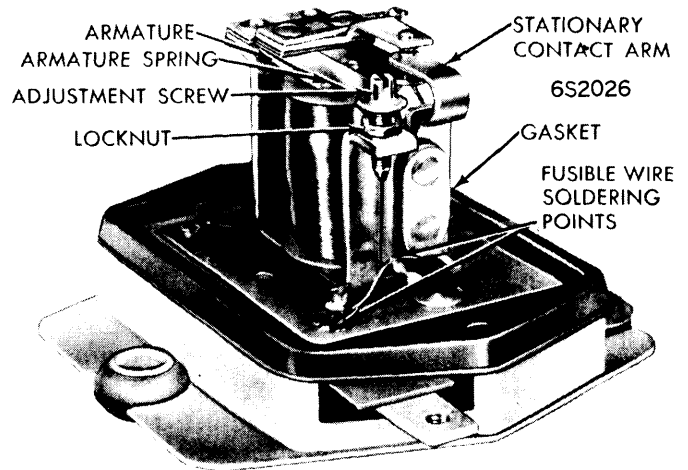

REGULATOR FUSIBLE WIRE LOCATION