

Alternator Regulators

CHRYSLER CORP. DOUBLE CONTACT

►CHANGES, CAUTIONS, CORRECTIONS

►EXCESSIVE AMMETER FLUCTUATION CORRECTION:

This condition usually indicated by excessive ammeter pointer flutter, headlight flicker and heater blower motor speed variations at steady engine speeds, and may be caused by high resistance in field circuit to alternator or voltage regulator improperly set. For proper diagnosis and correction, proceed as follows: Run engine at various steady speeds with heavy electrical load (headlights and accessories on) to determine degree of fluctuation. Stop engine, disconnect lead at "IGN" terminal of regulator and install a jumper wire from "IGN" terminal to positive terminal of battery. Operate engine at 1250 RPM and observe flutter.

1) If ammeter is normal, trouble is corrosion or other high resistance in field circuit connectors. Clean and tighten all connections. **NOTE** - On cars with 7½ ampere fuse in circuit, clean fuse and holder terminals and tape fuse holder to prevent dirt and moisture entry.

2) If jumper wire did not correct the trouble or if ammeter fluctuation is excessive regardless of engine speed or electrical load, remove voltage regulator from car and solder a piece of copper wire between 38 ohm resistor terminal connected to "IGN" terminal of regulator and regulator base. **CAUTION** - Use only rosin core solder and be sure regulator base is heated enough for proper metal fusion.

3) Install regulator and adjust according to procedures and specifications below.

►REGULATOR NO. 2098300 FUSIBLE WIRE REPLACEMENT NOTE:

To replace fusible wires, proceed as follows: Cut blown wire from connection at rivet in regulator base (do not unsolder as voltage coil wire may be damaged), and unwind wire from regulator contact bracket. Use rosin core solder only, tin one end of Fusible Wire No. 2275242 and hold wire in recess in rivet against old fuse wire. Put a drop of solder on wires. When cool, pull fusible wire up and wrap around contact bracket and solder wire to bracket to be sure of a good connection.

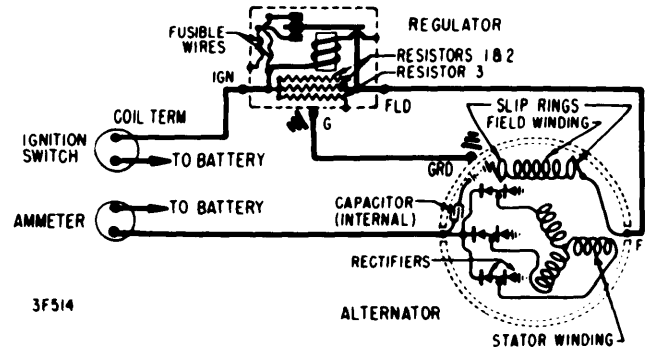

ALTERNATOR & REGULATOR INTERNAL CIRCUITS

DESCRIPTION & OPERATION

Field control type. Temperature compensated, vibrating type voltage regulator with two sets of contacts using a common armature. On Regulator No. 1889960, there is a 7½ ampere fuse in line between IGN terminal and ignition resistor. On Regulators No. 2095700 & 2098300, upper stationary contact bracket is connected to IGN terminal by a fusible wire, and lower stationary contact bracket is connected to ground by another fusible wire. Regulator operates on either upper or lower contacts (both sets are never in operation at the same time) depending on load and battery requirements as follows:

Upper Contact Operation (Low Speed & High Load) - Armature travel opens and closes upper contacts, cutting regulator resistance in and out of field circuit, and limiting alternator field current. Current is at maximum (no resistance) with contacts closed and is reduced (with resistance in series) with contacts open.

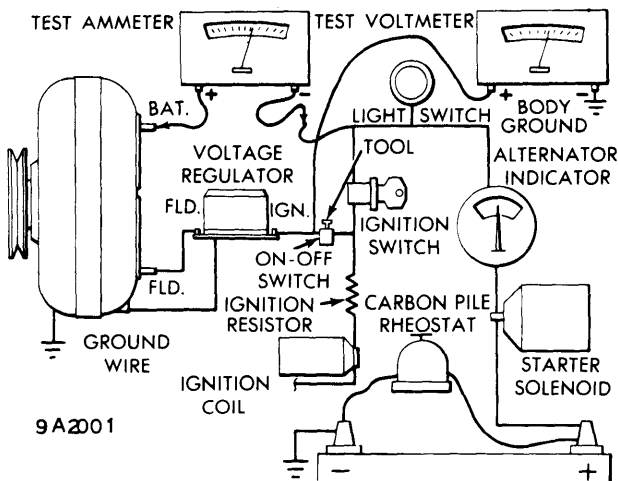

TEST CONNECTIONS (WITHOUT SPECIAL TEST SET)

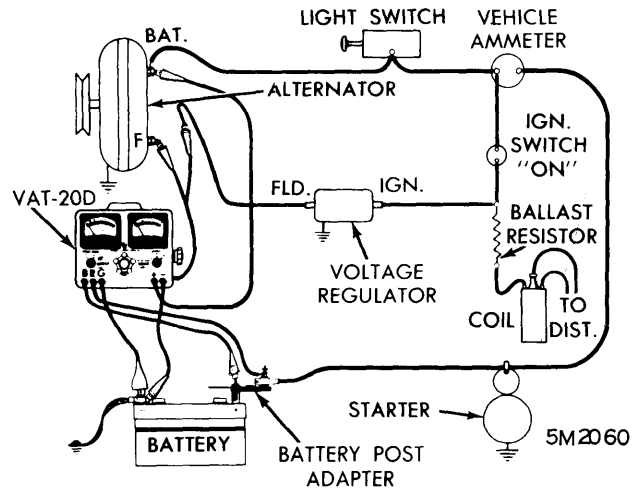

TEST CONNECTIONS (WITH SPECIAL TEST SET)

CHRYSLER CORP. DOUBLE CONTACT (Continued)

Lower Contact Operation (High Speed & Low Load) - Armature travel opens and closes lower contacts. Field current is reduced (with resistance in series) with contacts open, and field is grounded (no field current) with contacts closed. This limits alternator field current at a lower figure than with operation on upper contacts.

TESTING (ON CAR)

CAUTION - When making test connections, make certain ignition is OFF to prevent damage to regulator.

1) Make up a test switch tool by connecting leads to a simple "on-off" switch and connect this switch in series with lead removed from regulator IGN terminal. Connect positive terminal of test voltmeter to regulator lead terminal of on-off switch and ground opposite voltmeter lead. Connect 0-50 ampere ammeter in series with lead removed from alternator BAT terminal. Connect a carbon pile rheostat across battery terminals to vary load (or turn on lights and accessories to accomplish this result).

2) Start engine and operate at 1250 RPM, adjust carbon pile or lamp load for 15 ampere output as registered on test ammeter. **NOTE** - No ammeter reading indicates low setting on regulator or blown fusible wire and this condition must be corrected before proceeding with test. Operate engine at 1250 RPM with 15 ampere load for 15 minutes to normalize system temperatures.

3) **Upper Contact Test** - With temperature normalized, readjust engine speed to 1250 RPM and alternator output to 15 amperes. Note and record ambient temperature using accurate thermometer at a distance of 1/4" from regulator cover. Flash regulator by opening and closing on-off switch several times, then note voltage as indicated on test voltmeter. If voltage not within range for indicated temperature (see Specifications), remove regulator cover and adjust regulator (see Adjustment).

4) **Lower Contact Test** - Increase engine speed to 2200 RPM, adjust carbon pile (or turn off all lamps and accessories) to decrease output to 7 amperes as indicated on test ammeter. Voltage should increase. Recheck ambient temperature at regulator cover with thermometer to make certain it has not changed. Flash regulator by opening and closing on-off switch several times, then note voltage as indicated on test voltmeter. Voltage should not be less than .2 volt or more than .7 volt than voltage noted on Lower Contact Test at same ambient temperature (step 3 above). If voltage increase not within these limits, air gap or contact gap is not within specifications and should be adjusted (see Adjustment). **NOTE** - Voltage at engine speeds above 2200 RPM will be slightly higher but must not be more than .7 volt higher at any temperature range. If voltage less than .2 volt higher, check battery and make certain it is fully charged.

5) After tests completed, stop engine, disconnect battery and remove all test equipment, restore and tighten all regular circuit connections, then reconnect battery.

SPECIFICATIONS

AMBIENT TEMPERATURE NOTE - The ambient temperature is the temperature indicated on an accurate thermometer positioned 1/4" from regulator cover.

Voltage Setting (Lower Contact Test)

Ambient Temp.	Volts	Ambient Temps.	Volts
47°F.....	13.6-14.6	117°F.....	13.3-14.3
70°F.....	13.5-14.5	140°F.....	13.2-14.2
93°F.....	13.4-14.4	163°F.....	13.1-14.1

ADJUSTMENT

Lower Contact Point Gap - .014" ± .002". Adjust by bending lower stationary contact bracket making certain contact points are in alignment.

Air Gap - .048-.052" (nominal setting). To adjust, connect a dry cell test lamp in series with "IGN" and "FLD" terminals of voltage regulator, then insert a .048" wire gauge between regulator armature and core of voltage coil next to stop pin on spring hanger side. Press down on armature (not on contact reed) until armature contacts wire gauge. The upper contacts should just open and the test lamp should be dim. Insert a .052" wire gauge between armature and voltage coil core, next to stop pin on spring hanger side. Press down on armature until it contacts wire gauge. Upper contacts should remain closed and test lamp should remain bright. If an adjustment is required to obtain the difference between upper contact voltage and lower contact voltage of .2 to .7 volt; adjust the air gap by loosening stationary contact bracket screw and moving bracket up or down as necessary to obtain proper air gap setting as follows: If difference is above .7 volt, reduce air gap to a minimum of .045" (contacts open, test light dim), .048" contacts closed (test light bright). If difference is below .2 volt, increase air gap to maximum of .052" (contacts open, test light dim), .055" (contacts closed, test light bright). Make sure air gap is checked with stationary contact bracket attaching screw fully tightened.

Upper Contact Voltage Setting - Use an insulated tool to bend armature spring lower hanger down (to increase spring tension) to increase voltage setting, or up (to decrease spring tension) to lower voltage setting. Install regulator cover, reconnect regulator, and retest performance after each adjustment (step 3 under Testing).

Lower Contact Voltage Setting - If voltage increase is not within limits of .2 to .7 volt with correct lower contact gap setting, adjust air gap setting as follows: If difference is greater than .7 volt, reduce air gap to a minimum of .045" with contacts open (contacts must close with .048" air gap). If difference is less than .2 volt, increase air gap to maximum of .055" with contacts closed (contacts must close with .052" air gap). **CAUTION** - Contact bracket screw must be fully tightened when checking air gap.

Alternator Regulators

CHRYSLER CORP. DOUBLE CONTACT (Continued)

FUSIBLE WIRE REPLACEMENT

Cut fuse wire above solder connection at base and unwind wire at top bracket. *CAUTION - Attempts to unsolder old fuse may damage small wire from voltage coil.* Tin end of

fuse wire using resin core solder only. Hold tinned end of new fuse wire (No. 2275242) on recessed rivet at regulator base. Place soldering iron on rivet head and put a drop of solder on wires. When cool, pull fusible wire up and wrap around contact bracket and solder wire to bracket to insure good connection.

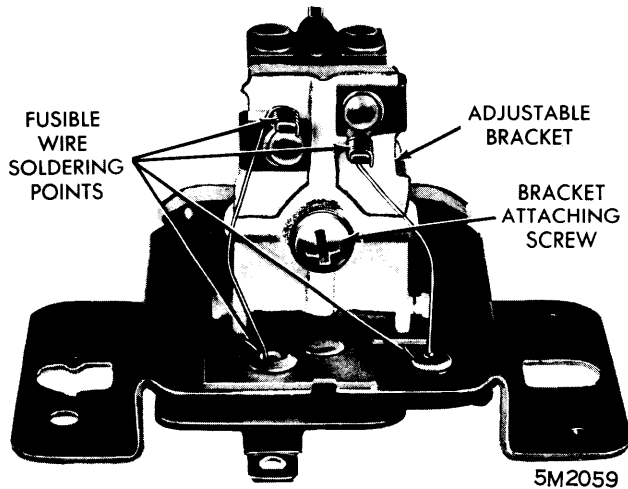

REGULATOR FUSIBLE WIRE LOCATIONS

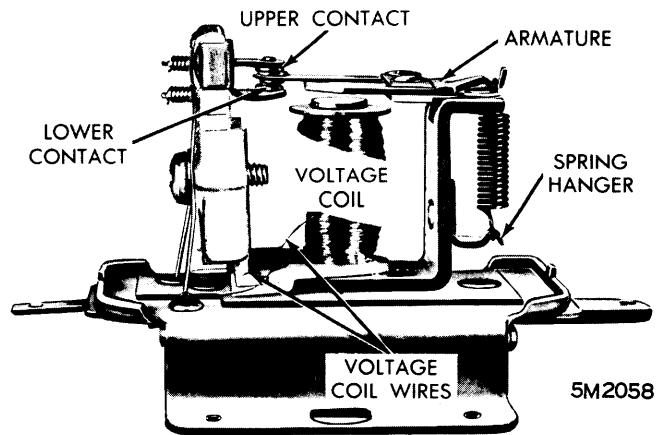

REGULATOR ASSEMBLY (WITH COVER REMOVED)