

## 1971-74 MOTOROLA

### DESCRIPTION

Motorola alternators are three phase stator wound using three positive and three negative silicon rectifier diodes. A diode trio assembly is used to rectify a portion of stator alternating current and appears as direct current and voltage for voltage regulator operation. Voltage regulators for American Motors and Jeep vehicles are solid state and automatically control alternator output and system voltage. The electrical circuits of the 37, 51 and 62 ampere alternators differ only in type of stator winding used. A delta wound stator is used for 51 and 62 ampere alternators and a "Y" wound stator is used for 37 ampere alternator. An auxiliary alternator terminal on rear housing provides about seven volts of alternating current for electric heated choke element used on all four barrel carburetors.

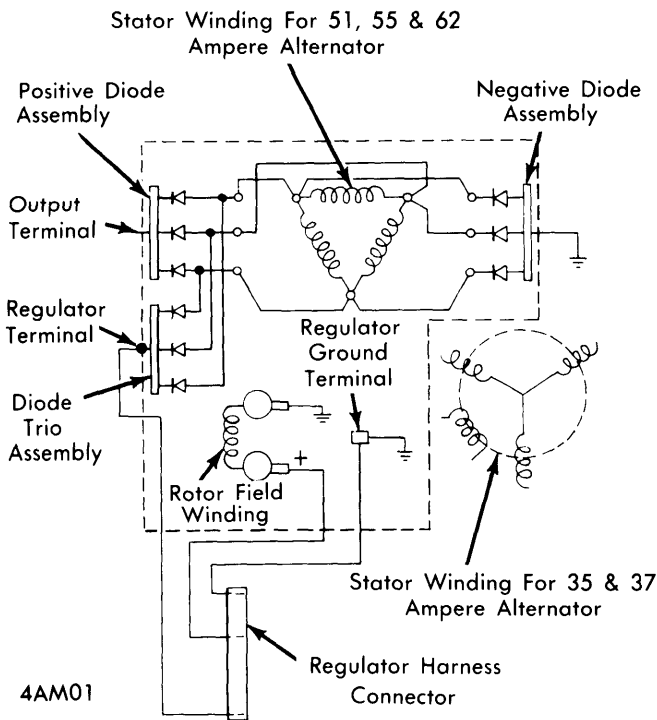

ALTERNATOR INTERNAL CIRCUITS

### IDENTIFICATION & SPECIFICATIONS

Alternator name plate on rear housing contains serial and model numbers, amperage rating, type of ground and voltage.

#### Alternator Specifications

Motorola No.	Output (Amps.)	Field Current (Amps.)
8AL2011F thru 2014F	35	1.8-2.5
8AL2015K and 2016K	55	1.8-2.5
8AL2021L	62	1.8-2.5
8AL2025F and 2026F	37	1.8-2.5
8AL2031F	37	1.8-2.5
8AL2032K	51	1.8-2.5
8AL2033L	62	1.8-2.5
8AL2044F and 2045F	62	1.8-2.5

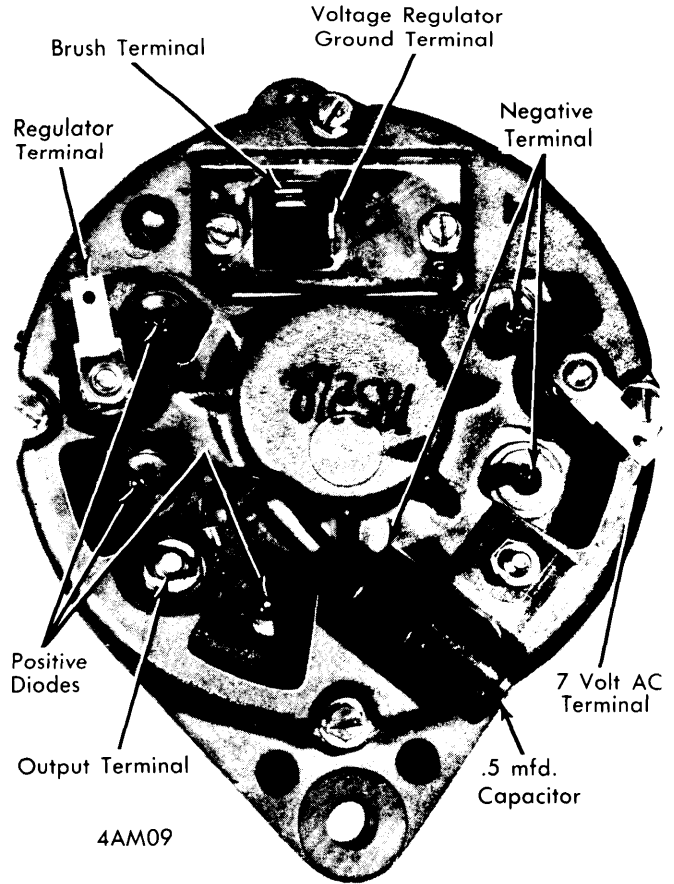

ALTERNATOR REAR VIEW

### TESTING

**CAUTION** — Do not disconnect alternator output lead or voltage regulator while alternator is operating. Do not ground field terminal.

#### ALTERNATOR

**Output Voltage Test** — Connect voltmeter to battery, start engine and turn headlights on low beam. Operate engine at 1000 RPM and observe voltage for about two minutes. If voltage remains above 13 volts, alternator and regulator are performing satisfactory. If not, perform following test.

**Field Amperage Draw** — Disconnect voltage regulator. Connect an ammeter between battery positive post and the GREEN wire leading to the insulated brush terminal (+) of alternator. The BLACK wire is connected to ground. The ammeter should read 1 1/2 to 3 amperes. Turn alternator rotor slowly by hand. If the reading varies, the slip rings require cleaning. If field draw is too high or low, remove alternator for further testing of field.

**Output Test (Regulator By-Passed)** — Perform this test to determine if alternator or voltage regulator is cause for low or no charge condition. Disconnect voltage regulator. Test Field Amperage Draw and disconnect ammeter after test. Connect a voltmeter to battery and start engine. Connect ammeter

## 1971-74 MOTOROLA (Cont.)

between battery positive post and alternator insulated brush. Observe reading while slowly increasing engine RPM. If 16 volts can be obtained, the alternator is not defective. **CAUTION** — Do not exceed 16 volts or damage to electrical components may result. If battery is dead, it may require charging for several minutes to obtain 16 volts.

### VOLTAGE REGULATOR

**Overcharging** — An overcharge is due to excessive voltage applied to alternator field. Excessive voltage may be caused by poor regulator ground, a defective battery or voltage regulator. Check regulator ground by connecting a jumper wire from regulator case to battery negative terminal. If voltage drops, repair regulator ground. Check BLACK wire connection of regulator to BLACK wire of engine compartment harness.

**Voltage Regulator Test** — Connect voltmeter to battery, turn headlights on low beam and operate engine for several minutes to bring regulator up to operating temperature. Set engine to 1000 RPM and note voltage. Voltage reading should be within specifications for temperature of the regulator.

### DIODE TRIO TEST (ON CAR)

A diode trio assembly with one or more diodes completely opened or shorted will cause reduced alternator output. Perform this test on diode trio to check for marginal defects which are not affecting alternator output, but may be cause of alternator indicator light glowing dimly. Test alternator output before diode trio test. To test diode trio, operate engine at idle

and connect a low reading voltmeter to alternator output and regulator terminals. Turn on headlights and place blower motor on high speed. Note voltmeter reading. If voltage drop is .6 volt or less, diode trio is satisfactory. If alternator indicator light continues to glow, inspect same circuit for loose or corroded connections.

### AUXILIARY AC TERMINAL

Check voltage at ac terminal by connecting a dc voltmeter to terminal and ground. With engine idling, voltage should be about 7 volts. **NOTE** — The maximum current that ac terminal will deliver is about 5 amps.

## OVERHAUL

### DISASSEMBLY

1) Remove regulator ground terminal plate and gasket. Pull brush assembly back to clear locating pins and tip assembly away from housing to remove brushes. Do not pull brush assembly straight out or damage may result. Scribe a line across housings for reassembly reference. Remove through bolts, separate rear housing and stator from front housing by using two screwdrivers to pry housings apart. Do not burr stator core or insert screwdrivers deeper than  $\frac{1}{16}$ " to avoid damaging stator windings.

2) Remove stator and diodes as an assembly by removing four lock nuts and insulating washers. Do not unsolder any

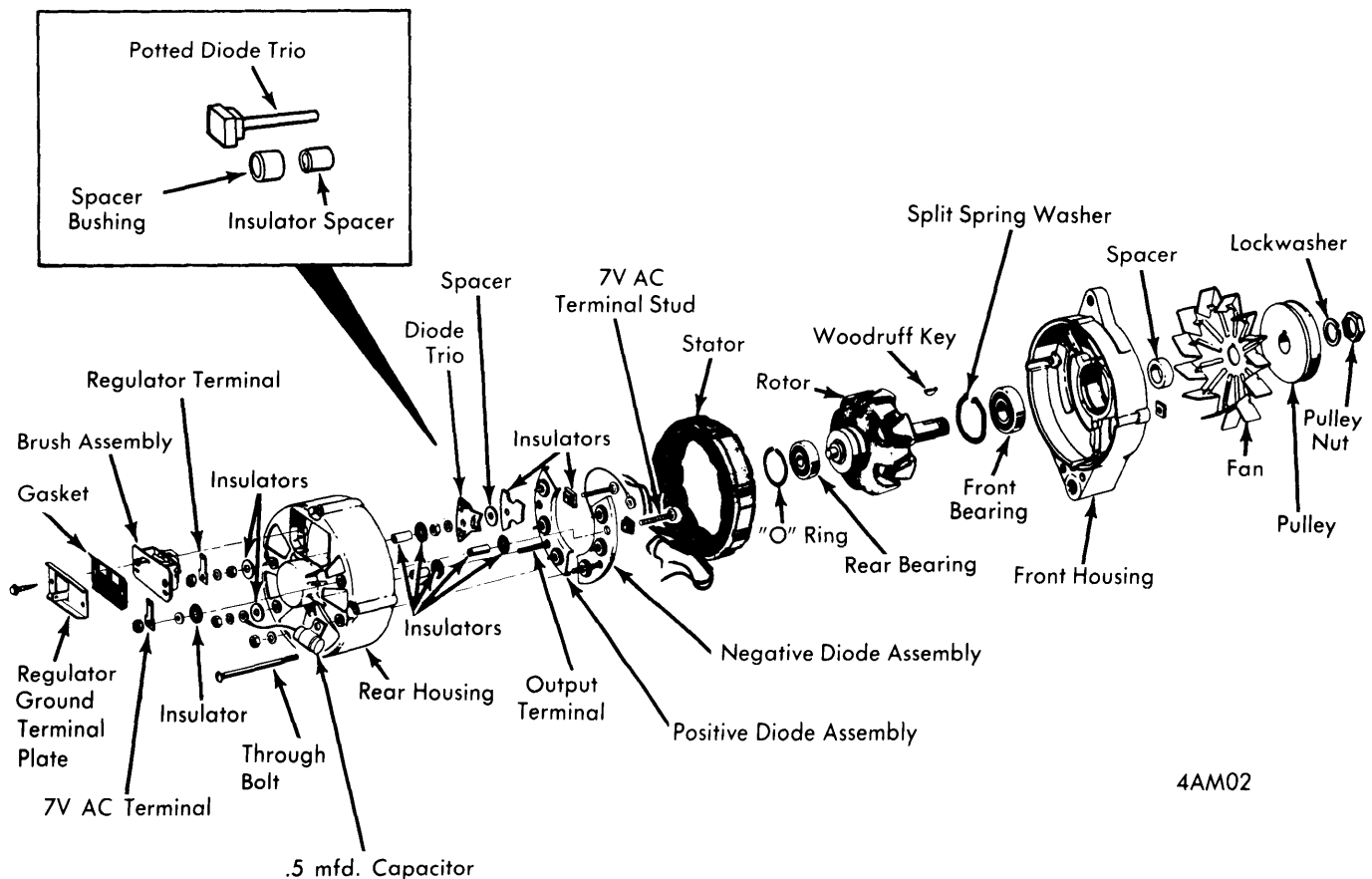

4AM02

### MOTOROLA ALTERNATOR

## 1971-74 MOTOROLA (Cont.)

stator to diode wire junctions. Avoid bending stator wires at each junction when removing the positive and negative diode assembly from the housing.

3) Remove board type diode trio by unsoldering leads at each positive diode. Remove diode trio attaching nut and diode trio. To remove potted diode trios, unsolder leads at diode trio. **NOTE** — Use no more heat than necessary to unsolder connections.

4) Remove rotor pulley using a double jaw puller. Remove woodruff key and spacer. The split ring washer must be unseated by inserting suitable tool (J-21157) through the front housing, and compressing the washer while exerting pressure toward rotor. The rotor and front bearing can be removed from front housing by tapping rotor shaft. Remove rotor bearings using suitable bearing puller (J21155).

### BENCH TESTING

**Rotor** — Check rotor for grounds using a 110 volt test light; no continuity should exist between slip ring and rotor shaft. Test for shorted windings using a current draw test (see illustration). Slowly reduce resistance of rheostat to zero. With battery voltage of 12.4-12.8 volts, field current should draw 1.8-2.5 amps. Excessive current draw indicates shorted windings and less than minimum current draw indicates open windings.

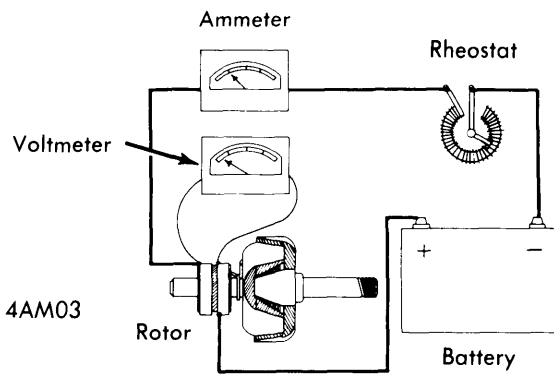

**ROTOR CURRENT DRAW TEST**

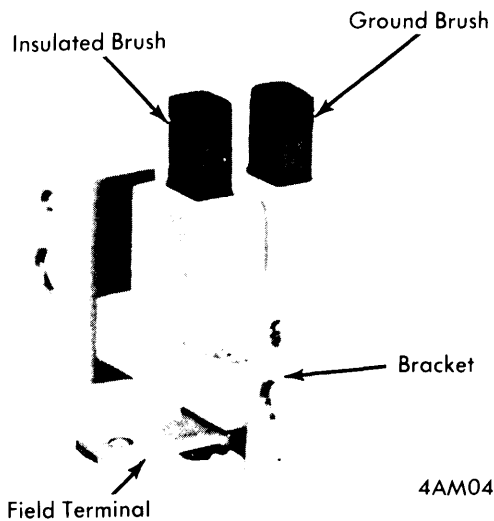

**BRUSH ASSEMBLY**

**Brush Assembly** — No continuity should exist between field terminal and bracket (see illustration). Continuity should exist only between field terminal and insulated brush, and between grounded brush and bracket.

**Diode Trio** — A testing device that draws a one amp. load (maximum) at 12 volts should be used (see illustration). **NOTE** — A test light or ohmmeter is not recommended for testing diodes as there is not enough of a load to check diode breakdown caused by heat. Unsolder wires at diode trio. Connect test device to battery as shown in illustration. Attach negative clip to common threaded stud terminal of diode trio and positive clip to one of the diode terminals. The test light flickers or goes out, the diode is defective. After 1-3 minutes with test light on, reverse the leads. If test light lights, diode is defective. Test other diodes in trio using same procedure.

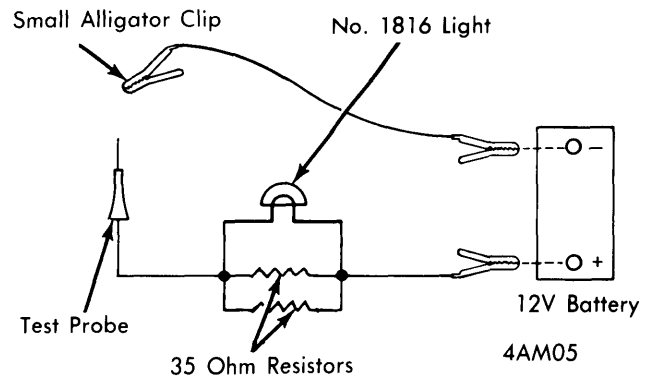

**DIODE TRIO LOAD TEST**

**Rectifier Diodes** — Unsolder wires from diodes, use needle nose pliers attached between diode and solder joint to absorb heat. A test apparatus that draws about 15 amps. is required (see illustration). Attach tester to a fully charged 12 volt battery. Connect test leads to diode heat sink and diode lead so lamp lights. Maintain test load on diode for 1-3 minutes; if light flickers or goes out, diode is defective. Reverse leads after 1-3 minutes; if lamp lights, the diode is defective. Test other diodes using same procedure.

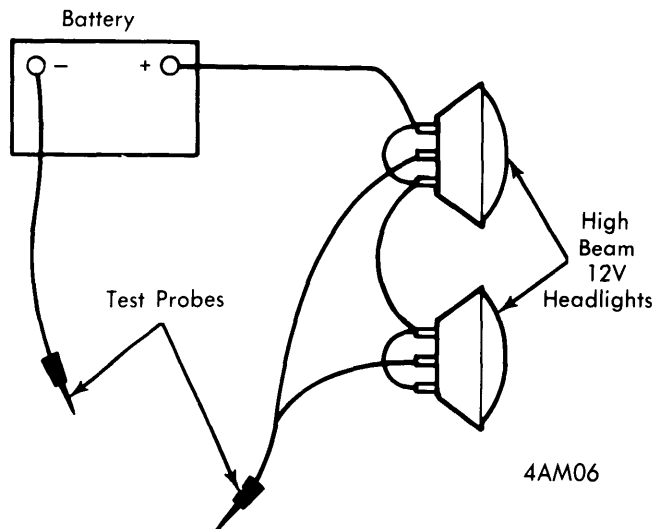

**RECTIFIER DIODE LOAD TEST**

## 1971-74 MOTOROLA (Cont.)

**Stator In-Circuit Test** — The stator may be tested with diodes connected to stator providing diodes are not defective. A shorted diode would make the stator appear to be shorted. **CAUTION** — Use a 12 volt test light or ohmmeter only. Connect test lead to a diode terminal and ground other lead. Reverse test leads; the light should come on in one direction only. If light does not come on at all, or lights in both directions, separate stator from diodes for further tests.

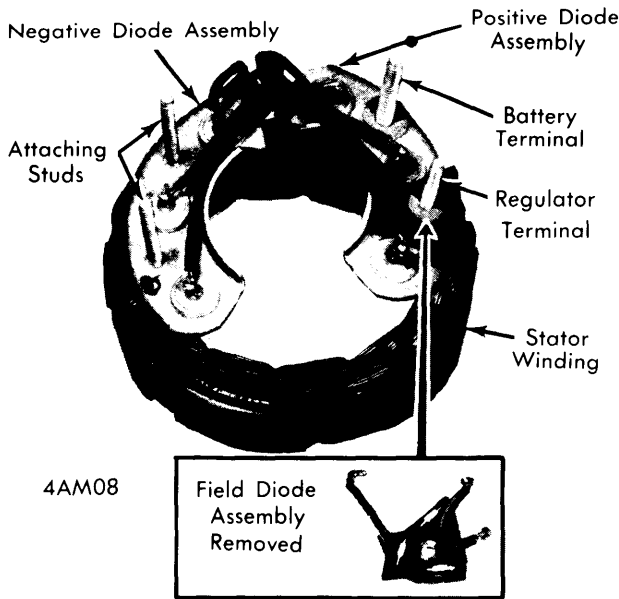

STATOR & DIODE ASSEMBLY

**Stator Load** — Perform this test with diodes unsoldered from stator leads. Use a voltmeter, ammeter, a variable load control and a fully charged 12 volt battery to test stator (see il-

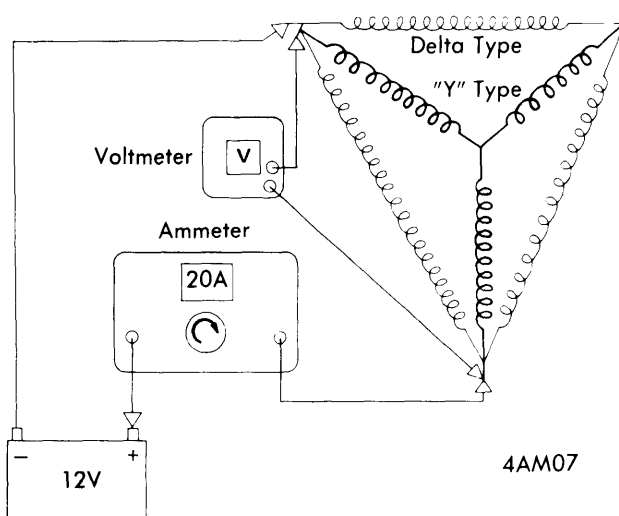

Alternator	Load	Maximum Voltage Drop	Maximum Variance Between Windings
37	20A	7.2 - 8.2	.7
51	20A	5.5 - 6.5	.6
62	20A	6.7 - 7.2	.5

STATOR LOAD TEST

lustration). Connect negative lead to any one stator lead and connect positive lead to load control. Connect remaining load control lead to either of the two stator leads. Connect voltmeter to stator leads and adjust load to draw 20 amps. Allow windings to heat up for about 15 seconds and record voltmeter reading. Reduce amperage draw to zero, disconnect voltmeter and load control leads. Repeat test for other stator windings. Variation between each winding must not exceed limits shown in table.

**Stator Grounds** — Test for grounds between windings and stator core using a test light or ohmmeter. No continuity should exist.

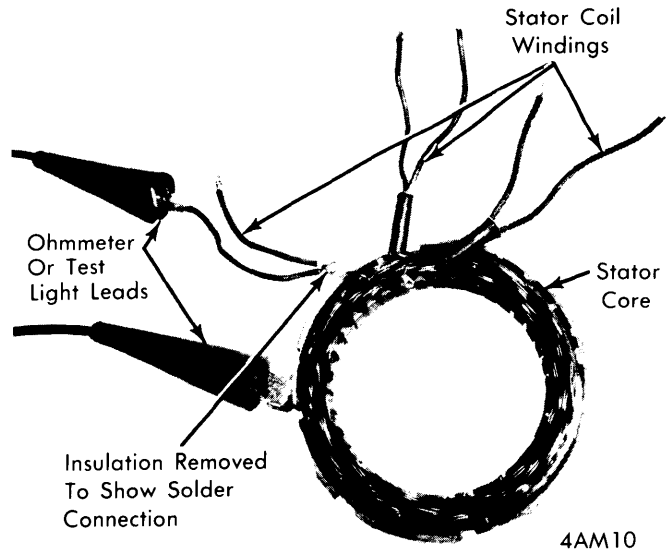

STATOR COIL SHORT TEST

### REASSEMBLY

1) Install front bearing using a 1 1/8" socket to press bearing into place. Insert split spring washer into hub of front housing and use suitable tool (J-21154) to seat washer into groove of hub. **NOTE** — Do not compress washer with any object that can slip off and damage bearing seal.

2) Lightly lubricate rotor shaft before installing. Use suitable bearing press (J-21156) to install rotor to front housing. Install fan, pulley spacer, key and pulley. Use a 7/16" socket to fit the inside race of the rear bearing and apply sufficient force to drive bearing against shoulder of rotor shaft.

3) Install stator assembly to rear housing as follows: Install flat fiber washers on positive diode attaching studs. If equipped with 7 volt ac terminal, install a fiber washer on the ac stud. Place stator in rear housing and install plastic sleeves on all insulated terminals. Install flat fiber washers, metal flat washers and locknuts. Before tightening the ac terminal, check that diode wire end does not contact heat sink. Install two terminal blades, tighten securely, and install rear housing assembly to front housing.

4) Check slip rings for grease or dirt before installing rear housing. Align scribe marks previously marked when joining alternator housings. Check that insulating washers are installed on regulator and battery terminals. If equipped with 7 volt terminal, note that terminal also serves as one of the negative diode assembly attaching studs. This is the only negative diode assembly stud that must be insulated from the rear housing. Install through bolts and turn rotor to check for free movement.

## 1971-74 MOTOROLA (Cont.)

