

## ALL MODELS

### GENERAL INFORMATION

All steering component fasteners are made of special quality materials. Replacement fasteners must be of same part number or equivalent. Do not weld, heat or bend steering linkage to repair or straighten. Torque all fasteners to specification and install new cotter pins. When installing cotter pins, do not back off castellated nuts to align cotter pin hole, tighten nut to lower specified torque; then tighten nut to next slot that lines up with stud hole. Do not hammer on ball studs or damage to threads may result. Threads should be clean and lightly lubricated with oil before being tightened.

### REMOVAL & INSTALLATION

#### TIE RODS

**Removal** — Raise vehicle and remove cotter pins and nuts from ball studs. Use a suitable puller to separate ball studs from steering knuckle and center cross link. To remove tie rod ends from adjuster sleeve, remove clamp bolts and unscrew end assemblies.

**Installation** — If tie rod ends were removed, apply penetrating oil to clamps, tie rod threads and sleeve. Wipe threads clean and lubricate with EP chassis lube. Place sleeve clamps in position and thread tie rod ends an equal distance into sleeve. Install tie rod assembly, castellated nuts and new cotter pins. Rotate tie rod ends rearward to limit of ball stud travel, then position sleeve clamps and tighten bolts. Lower vehicle and adjust toe-in. See *Wheel Alignment Specifications & Procedures* in WHEEL ALIGNMENT Section.

#### CENTER LINK

**Removal & Installation** — Using a puller or tie rod separator, disconnect inner tie rod ends, idler arm and pitman arm from center link. Remove center link from vehicle. To install reverse removal procedure, make sure idler arm stud seal is in place, and adjust toe-in.

#### IDLER ARM

**Removal** — 1) Raise vehicle and disconnect center link from idler arm. Remove two bolts attaching idler arm support to frame (note bolt direction).

**NOTE** — If idler arm support is disconnected from frame for other work, wire support to idler arm to prevent rotation if equipped with a threaded bushing (G.M. Saginaw linkage types).

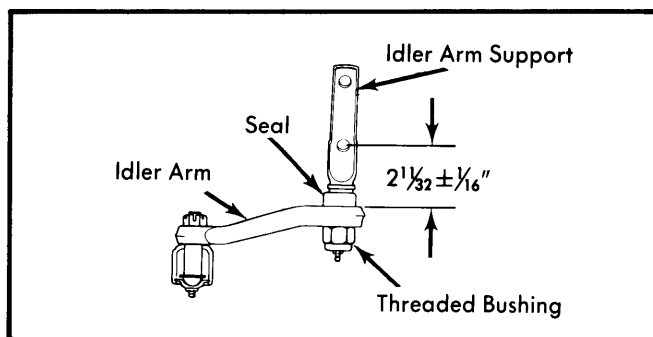

**Fig. 1 Idler Arm Positioning**  
(G.M. Models with Threaded Bushing)

2) Maximum allowable lash or vertical deflection of relay rod end of idler lever is  $\frac{1}{8}$ " when a 25 lb. load is applied at that point. Replace assembly if deflection is more than  $\frac{1}{8}$ ".

**Installation** — To install idler arm, reverse removal procedure and note the following: On G.M. models equipped with threaded bushing, an adjustment is required to ensure that idler arm ball socket is level with pitman arm socket. Idler arm support must be threaded into bushing until set as shown in Fig. 7. When idler arm is installed on support, it must be free to rotate 90° in both directions from straight ahead.

#### PITMAN ARM

**Removal** — 1) Raise vehicle and mark position of pitman arm to steering shaft relationship. Remove cross link ball stud cotter pin and nut. Using suitable puller, disconnect cross link from pitman arm.

2) On Eldorado, Seville, Riviera and Toronado models, it is necessary to disconnect and/or remove steering gear from its mounting before removing pitman arm. Remove pitman arm retaining nut and lock washer. Install suitable puller and remove pitman arm.

**NOTE** — DO NOT hammer on end of puller as damage to steering gear components may result.

**Installation** — To install pitman arm, reverse removal procedure and tighten nuts as required.

### TIGHTENING SPECIFICATIONS

Application	Ft. Lbs. (N·m)
Tie Rod End Nuts	
American Motors, Chrysler & Ford	35-45 (47-61)
General Motors	
Eldorado, Riviera,	
Seville & Toronado (Inner End Only)	55-65 (75-88)
All Others	30-40 (41-54)
Idler Arm-to-Center Link	
American Motors & Chrysler	35-45 (47-61)
Ford	60-70 (81-95)
General Motors	
Eldorado, Riviera,	
Seville & Toronado	55-65 (75-88)
All Others	35-45 (47-61)
Idler Arm-to-Frame	
American Motors	50-60 (68-81)
Chrysler	65-75 (75-102)
Ford	85-95 (115-129)
General Motors	
Corvette	25-35 (34-47)
All Others	50-60 (66-81)
Pitman Arm-to-Center Link	
American Motors, Chrysler & Ford	40-45 (54-61)
General Motors	
Eldorado, Riviera,	
Seville & Toronado	50-60 (66-81)
All Others	40-45 (54-61)