

FORD MOTOR CO. RACK & PINION

Capri, Mustang
Cougar, Granada
Escort, Lynx
EXP, LN7
Fairmont, Zephyr

DESCRIPTION

Steering is rack and pinion type, with input pinion shaft causing rack to move from side to side when steering wheel is turned. On front wheel drive models, the input shaft is connected to the steering shaft by a double "U" joint shaft. On rear wheel drive models, the input shaft is connected to the steering shaft by a single "U" joint shaft and a flexible coupling. Tie rods are attached at each end of the rack. All rear wheel drive models require 5 ounces of lubricant. All front wheel drive models require 3.2 ounces of lubricant. Refilling is not necessary unless gear is disassembled or leakage is evident.

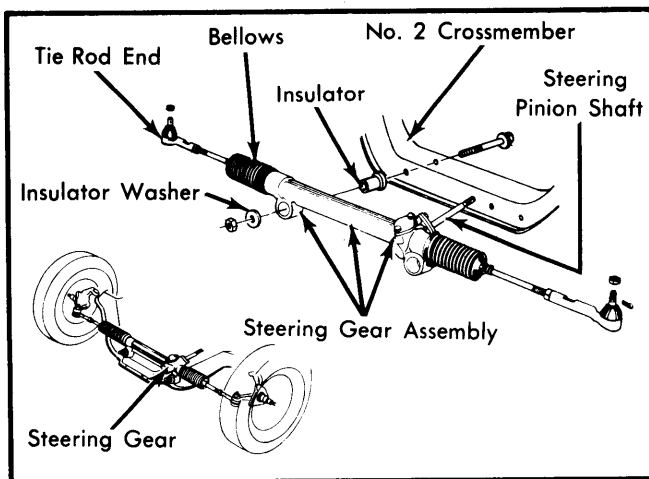

Fig. 1 Rack and Pinion Steering Assembly for Rear Wheel Drive Models

ADJUSTMENT

Rack and pinion gear provides two means of service adjustment. Steering gear must be removed from vehicle to perform these adjustments.

SUPPORT YOKE-TO-RACK CLEARANCE

- 1) Clean exterior of steering gear thoroughly and mount gear in a soft-jawed vise or suitable holding fixture.
- 2) Remove yoke cover, gasket, shims and yoke spring. Clean cover and housing flange areas thoroughly. Reinstall yoke and cover **WITHOUT** gasket, spring and shims. Tighten cover bolts lightly until cover just touches yoke.
- 3) Measure gap between cover and housing flange, then select shims which, together with cover gasket, are .005-.006" thicker than the measured gap.
- 4) Remove cover, assemble gasket on housing flange, then install shim pack, spring and cover. Install and tighten bolts evenly. Check steering gear for binding or looseness and smooth operation.

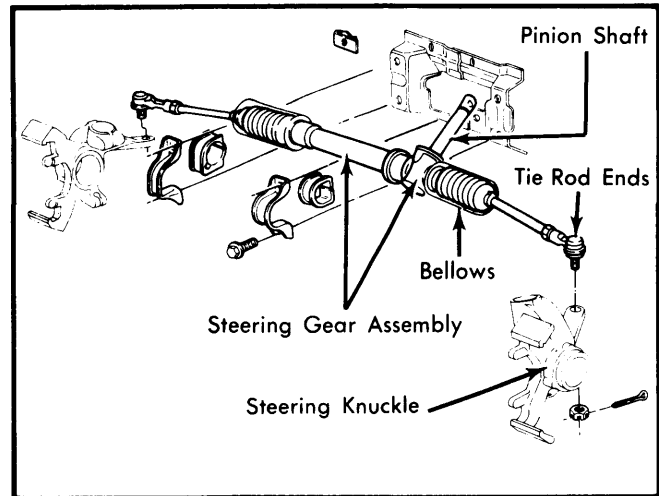

Fig. 2 Rack and Pinion Steering Assembly for Front Wheel Drive Models

TIE ROD MOVEMENT EFFORT

Install hook end of pull scale through hole in tie rod end stud. Effort to move tie rod should be 1-5 lbs. **DO NOT** damage tie rod neck. Replace tie rod/ball joint assembly if effort falls outside this range. Save tie rod end for use on new assembly.

PINION BEARING PRELOAD

- 1) Clean exterior of steering gear thoroughly and mount gear in a soft-jawed vise or suitable holding fixture.
- 2) Loosen yoke cover bolts to relieve spring pressure on rack. Remove pinion cover and clean cover flange area thoroughly, then remove cover gasket, spacer and shims.
- 3) Install new gasket on pinion cover flange, fit shims between upper bearing and spacer until shim pack is flush with top surface of gasket (check with light pressure on straight-edge placed on gasket face), then add one .005" shim to preload bearings.

NOTE — Spacer must be assembled next to housing cover.

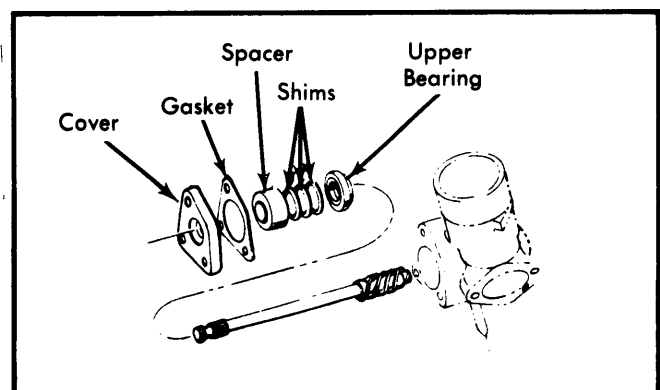

Fig. 3 Pinion Bearing Preload Adjustment. Build Up Shim Pack Until Flush With Gasket Surface, Then Add .005" Shim For Preload.

FORD MOTOR CO. RACK & PINION (Cont.)

4) On front wheel drive models, remove oil seal from cover and install cover using centering tool (T81P-3504-Y). Install pinion oil seal. On rear wheel drive models, install cover bolts and tighten evenly.

STEERING WHEEL CHECK

With front suspension in good condition and steering gear properly adjusted, free play measured at steering wheel rim should be no more than $\frac{3}{8}$ ". When turning steering wheel from one stop to the other with vehicle stationary, steering gear should not knock (a knock indicates that steering gear adjustment is required).

NOTE — Do not turn steering wheel forcefully from stop to stop with front wheels off ground. Build-up of pressure within gear could cause damage or blow off bellows.

REMOVAL & INSTALLATION

STEERING GEAR

Removal (Rear Wheel Drive Models) — Disconnect negative battery cable. Remove bolt retaining flexible coupling to input shaft. Turn key to "ON" position. Raise vehicle on hoist. Remove tie rod ends from spindle arms. Support steering gear and remove retaining bolts holding gear to crossmember. Remove gear assembly from vehicle.

Removal (Front Wheel Drive Models) — 1) Disconnect negative battery cable. Turn key to "ON" position. Remove access panel from dash, below steering column. Remove intermediate shaft bolts at gear input shaft and steering column shaft.

2) Using wide-blade screwdriver, spread slots enough to loosen intermediate shaft at both ends. Turn steering wheel to full left so tie rod will clear shift linkage.

3) From under vehicle, separate tie rod ends from steering knuckle with suitable removal tool. Turn right wheel to full left turn position. Remove left tie rod end from tie rod.

4) On automatic transmission models, disconnect speedometer cable at transmission. Disconnect secondary air tube at check valve. Disconnect exhaust system at exhaust manifold. Support exhaust system to allow enough clearance for gear removal.

5) Remove exhaust hanger bracket. Remove steering gear mounting brackets and insulators. Separate gear from intermediate shaft by having someone pull up on the shaft from inside the car. Rotate gear forward and down to clear input shaft through dash panel opening.

6) With input shaft in full left turn position, move gear through passenger side apron opening until left tie rod clears shift linkage. Lower left side of gear and remove from vehicle, taking care not to rip the rubber bellows.

Installation (All Models) — To install, reverse removal procedures and note the following: On front wheel drive models, make sure that flat part of gear left side mounting area is parallel to dash panel. Tighten the left mounting bracket first to locate the gear properly. Check and adjust toe in.

OVERHAUL

TIE ROD ENDS, BALL JOINT SOCKETS & BELLOWES

Disassembly — 1) Clean exterior of gear thoroughly, then mount in suitable holding fixture. Loosen jam nuts on outer ends of tie rods. Remove tie rod ends and jam nuts.

2) Loosen clamps retaining bellows to gear housing and tie rods. Drain lubricant and remove bellows. On front wheel drive models, remove set screw from ball housing with allen wrench. On rear wheel drive models, remove spiral pin from ball housing with suitable tool.

3) Install ball housing torque adapter tool (T78P-3504-AA) on ball housing. Locate the point of the locking screw in large hole midway along length of housing and tighten firmly.

NOTE — Use care not to place point of locking screw into tapped set screw hole.

4) Attach a $\frac{1}{2}$ " drive ratchet handle to tool. Expose enough rack teeth to install an adjustable wrench over the flat formed by the tops of rack teeth. Loosen ball housing tie-rod assembly by holding adjustable wrench and turning ball housing torque adapter tool.

CAUTION — If rack is not restrained by adjustable wrench, the pinion will be damaged.

Reassembly — 1) Clean and inspect threads on rack and in ball housing socket. On front wheel drive models, lubricate inner seat with multi-purpose lubricant.

NOTE — On front wheel drive models, ensure ball housing is firmly seated in housing socket and on tie rod ball. Back of inner seat and end face of rack must be wiped clean of any grease to avoid a hydraulic lock and improper assembly.

2) Thread tie rod assembly onto end of rack. Install ball housing torque adapter tool on ball housing. Locate point of locking screw in large hole midway along housing and tighten firmly.

NOTE — Use care not to place point into tapped set screw hole.

3) Hold rack with adjustable wrench on flat of rack teeth, as near the end as possible. If pinion has not been removed, use care not to load pinion during tightening.

4) Tighten ball housing by turning adapter tool with a $\frac{1}{2}$ " drive torque wrench. Rotate tie rod at least 10 times before measuring articulation effort.

NOTE — Do not force tie rod against limits of articulation travel.

5) If tie rod movement effort is not within specifications, replace with a new tie rod assembly. On front wheel drive models, install set screw in ball housing and tighten.

6) On rear wheel drive models, insert spiral retaining pin into small hole on ball housing, tapping lightly until pin is seated.

FORD MOTOR CO. RACK & PINION (Cont.)

7) On all models, apply lubricant to undercut in tie rod where bellows will be clamped. Install small bellows clamp. Install large bellows clamp on right side only.

8) Place gear in vertical position with pinion end up. Fill housing with proper amount of lubricant. Install large bellows clamp on left side. Install jam nuts and tie rod ends on tie rods.

INPUT SHAFT SEAL

Removal & Installation — Thoroughly clean input shaft and seal area. Pry pinion seal from bore, taking care not to damage shaft. On front wheel drive models make sure pinion cover is centered. Lubricate inside of new seal and install over shaft. Using a piece of tubing, press or tap seal into bore until flange is flush with shoulder of bore.

PINION ASSEMBLY, BEARINGS, RACK & HOUSING

Disassembly — 1) Clean exterior of gear thoroughly and place in suitable holding fixture. Remove yoke cover, shims, spring and yoke. Remove right hand ball housing/tie rod assembly and position rack to right hand stop.

2) Note position of flat on input shaft (front wheel drive models), or "D" shaped groove (rear wheel drive models), for proper reassembly. Remove pinion cover and gasket. Remove pinion shaft, spacer and shims. Remove upper bearing and pinion seal. Remove rack from housing and remove lower pinion bearing.

NOTE — Flat or "D" shaped groove must be in same position upon assembly so that steering wheel will be in straight ahead position.

Reassembly — 1) Install lower bearing in pocket at bottom of housing. On front wheel drive models, coat the entire length of rack with grease. Install rack in housing.

2) With rack moved to right stop, install pinion shaft. Make sure pinion shaft end is engaged in lower bearing inside diameter. Install upper bearing.

3) On rear wheel drive models, install shims, spacer, gasket, pinion cover and bolts. Adjust bearing preload.

4) On front wheel drive models, turn pinion from lock to lock, counting the number of turns. Turn pinion back from lock half the total number of turns. The flat on pinion gear must at 3 o'clock as viewed from driver's position. If pinion is incorrectly oriented, remove pinion gear and re-engage gear teeth to correct.

5) Install shims, spacer, gasket, pinion cover and bolts. Center pinion cover and check bearing preload. Adjust if necessary. Install new pinion seal in cover.

6) On all models, install right ball housing/tie rod assembly on end of rack. Install support yoke, spring, shims, gaskets, yoke cover and bolts. Adjust yoke preload.

NOTE — Make sure rack is restrained with an adjustable wrench during tightening to prevent damage to pinion teeth.

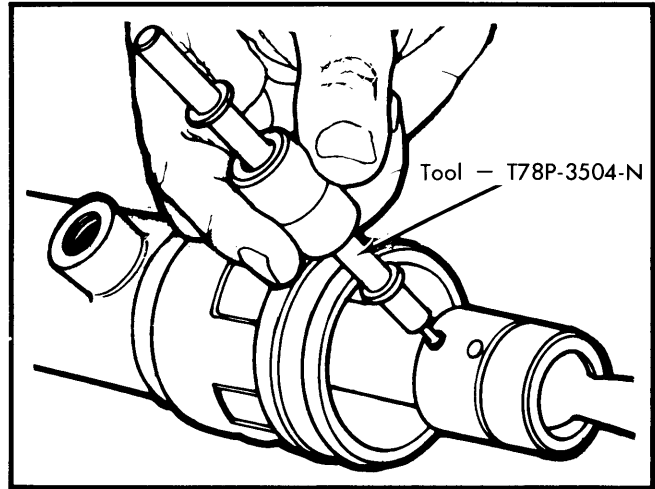

Fig. 4 Removing Spiral Pin on Rear Wheel Drive Models

TIGHTENING SPECIFICATIONS

Application	Ft. Lbs. (N·m)
Front Wheel Drive Models	
Pinion Cover Bolts	12-18 (16-24)
Steering Gear Mounting Bolts	48-55 (65-75)
Tie Rod-to-Spindle Nut	⓪27-32 (37-43)
Tie Rod Jam Nut	42-50 (57-68)
Flex Coupling Bolt	20-37 (27-50)
Ball Housing-to-Rack	40-51 (54-69)
Support Yoke Cover Bolts	60-96 INCH Lbs. (7-11)
Rear Wheel Drive Models	
Support Yoke Cover Bolts	15-22 (20-30)
Pinion Cover Bolts	15-22 (20-30)
Steering Gear Mounting Bolts	90-100 (122-136)
Tie Rod-to-Spindle Nut	⓪41-47 (56-64)
Tie Rod Jam Nut	41-50 (56-68)
Flex Coupling Bolt	20-37 (27-50)
Ball Housing-to-Rack	45-60 (61-81)

⓪ — Tighten to nearest cotter pin slot after torquing to specification.