

AMERICAN MOTORS & GENERAL MOTORS

American Motors
Buick
Cadillac
Oldsmobile

DESCRIPTION

The Electronic Level Control is a leveling system that automatically adjusts rear height of vehicle with varying loads on rear suspension. System is activated when ignition switch is on and weight is added to or removed from rear of vehicle. System is made up of a compressor, air dryer, exhaust solenoid, compressor relay, height sensor and air adjustable shock absorbers. Eldorado, Seville, Toronado and Riviera have 2 compressor relays and an air pressure limiting valve that keeps shock air pressure below 90 psi.

TROUBLE SHOOTING

CAR LOADED, WILL NOT RISE

Leaks in lines, fittings or shock absorbers. Pinched lines between compressor and shock absorbers. Defective height sensor. Compressor inoperative. Loose or bad electrical connection to sensor or compressor.

CAR LOADED, RISES, THEN LEAKS DOWN

Severe leak in lines, fittings or shock absorbers.

CAR LOADED, RISES PARTIALLY

Height sensor out of adjustment. Compressor or wiring defective.

CAR RISES WHEN LOADED, LEAKS DOWN WHEN DRIVING

Defective dryer or compressor. Pinched lines or leaks in fittings or lines.

CAR RIDES HIGH

Height sensor out of adjustment. Dryer plugged or lines pinched. Poor electrical connection.

NOTE — Refer to WHEEL ALIGNMENT Section for riding height measuring points and measurements.

TESTING

SYSTEM OPERATIONAL TEST

NOTE — Cycle system by turning ignition switch "OFF" and "ON". On Eldorado, Riviera, Seville and Toronado, transmission selector must be in "REVERSE". This procedure will reset the height sensor timer circuit.

1) Measure vehicle riding height and start engine momentarily. Leave ignition switch "ON".

2) Apply approximately 200 lbs. load to rear of vehicle.

- There should be 8-14 seconds delay before compressor turns on and vehicle begins to raise.
- Vehicle should raise to within $\frac{3}{4}$ " of riding height by the time compressor shuts off.

NOTE — Be sure applied load has not exceeded system capacity. This could cause failure of vehicle to rise to $\frac{3}{4}$ " of unloaded height.

3) After removing load, there should be 8-14 seconds delay before vehicle begins to lower.

4) Vehicle should be within $\frac{3}{4}$ " of the unloaded height in $3\frac{1}{2}$ minutes.

COMPRESSOR TEST

1) Disconnect wiring from compressor and exhaust solenoid terminals. See Fig. 1.

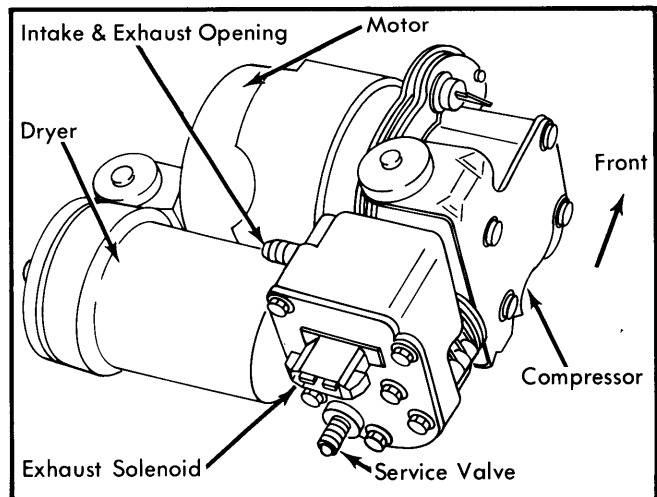

Fig. 1 Electronic Level Control Compressor

2) Disconnect pressure line from dryer and attach air pressure gauge to dryer fitting.

3) Connect 12 Volt power supply through ammeter to compressor.

- Current draw must not exceed 14 amps.
- Allow gauge to stabilize between 100-120 psi.

4) Shut off compressor and observe if pressure leaks below 90 psi.

NOTE — If compressor is allowed to run to maximum output pressure (120-180), the solenoid exhaust valve will act as a relief valve. This gives a FALSE indication of system leakage.

5) If compressor operates correctly, reconnect wiring and air lines.

ELECTRICAL TROUBLE SHOOTING

COMPRESSOR WILL NOT RUN

- 1) Check ground wire and 12 Volt connection to compressor.
- 2) Disconnect 12 Volt connection and jumper from battery to compressor.

- If compressor does not run, replace compressor.
- If compressor runs, locate open in 12 volt wire.

AMERICAN MOTORS & GENERAL MOTORS (Cont.)

- 3) Place jumper wire between terminal relay and ground.
 - If compressor does not run, replace relay.
 - If compressor runs, disconnect jumper wire and go to step 4.
- 4) Check wiring to sensor for security and proper grounding. Make sure adjustment nut is tight and link is properly installed. Check for correct sensor being installed.
 - If all items check out good, go to step 5.
- 5) Check height sensor for proper operation.
 - If compressor runs, make adjustment on sensor as necessary.
 - If compressor does not run, go to step 6.
- 6) Disconnect height sensor wiring and install test light to ground. Transmission must be in reverse on Eldorado, Riviera and Tornado models. Probe terminals No. 5 and 6 on sensor harness connector.
 - Light should be on at both terminals.
 - If no light, locate open in B+ circuit to sensor.
 - If test light on, go to step 7.
- 7) Connect jumper wire to terminal No. 3 and ground.
 - If compressor does not run, check for open in wire between compressor and sensor.
 - If compressor runs, on Century and Cutlass Ciera, perform height sensor operational check. On all others, connect jumper between terminals 3 and 4.
 - If compressor doesn't run, repair ground wire from height sensor. If compressor runs with both 3-to-ground and 3-to-4, make sensor operational check.

COMPRESSOR RUNS CONTINUOUSLY

- 1) Disconnect yellow wire (brown wire on Buick models) from compressor relay and plug connector back on relay.
 - If compressor still runs, replace relay.
 - Be sure 8-14 second relay functions. If delay fails to function, replace height sensor.
 - If compressor stops, replace wire in connector, reconnect relay and go to step 2.
- 2) Disconnect height sensor wiring.
 - If compressor stops, replace height sensor.
 - If compressor still runs, locate open in wire from terminal No. 3 to relay.
- 3) Check height sensor time delay function.
 - If no time delay, replace both sensor and relay.
 - If time delay is good, check circuit between compressor relay and height sensor for intermittent grounding condition.

- 4) Check for defective relay by tapping on case. If relay clicks, replace it.

RESIDUAL AIR CHECK

System has valving arrangement to maintain residual pressure of 8-15 psi (14-20 psi on Eldorado, Riviera, Seville and Tornado) in shock absorbers. Test as follows:

- 1) Attach air pressure gauge with tee fitting between dryer and air pressure line.
- 2) On Century and Cutlass Ciera models, disconnect relay and jumper 12 volts to compressor terminal to run compressor. Disconnect exhaust solenoid and jumper 12 volts to white wire terminal to exhaust system. Gauge should read 8-15 psi.
- 3) On all other models, turn ignition "ON" to inflate shock absorbers. Turn ignition "OFF" to exhaust system. Gauge should read 8-15 psi (14-20 psi on Eldorado, Riviera, Seville and Tornado) after system is deflated.

HEIGHT SENSOR OPERATIONAL TEST

- 1) Cycle system with ignition switch.
- 2) Raise vehicle on hoist and support axle housing at riding height.
- 3) Check all wiring for good connections.
- 4) Disconnect link from height sensor arm. See Fig. 2.

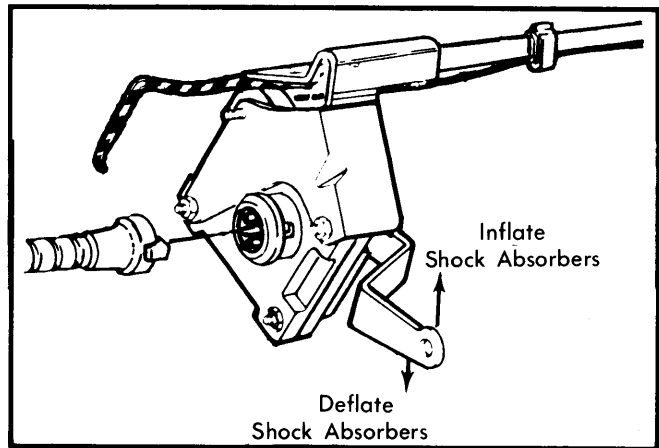

Fig. 2 Height Sensor Test

- 5) Move metal sensor arm "UP".
 - There should be a delay of 8-14 seconds before compressor turns "ON" and shock absorbers start to inflate.
 - As soon as shock absorbers fill, stop compressor by moving metal sensor arm "DOWN".
- 6) Move sensor arm below position where compressor stopped running.
 - There should be a delay of 8-14 seconds before shock absorbers start to deflate and vehicle lowers.
- 7) If height sensor does not function properly, replace it with correct model.

AMERICAN MOTORS & GENERAL MOTORS (Cont.)

ADJUSTMENT

HEIGHT SENSOR

1) Attach link to arm and loosen lock nut. See Fig. 3.

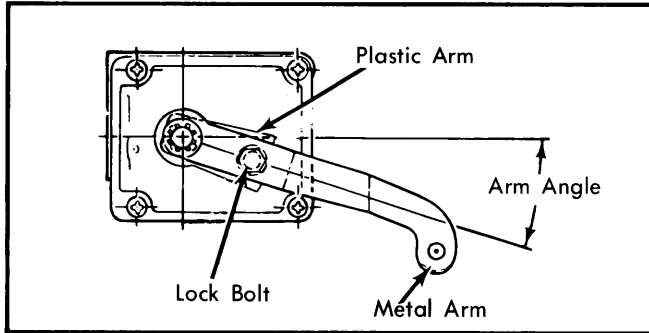

Fig. 3 Height Sensor Adjustment

2) To increase vehicle riding height, move plastic arm upward and tighten lock nut.

NOTE — If adjustment is used up, check riding height.

3) To lower riding height, loosen lock nut and move plastic arm down. Tighten lock nut.

4) If adjustment can not be made, check for incorrect sensor being installed.

Height Sensor Identification

Application	Code
American Motors	⓪
Buick	
Century	⓪
Electra, LeSabre	BF
Estate Wagon	BJ
Riviera	BA
Skylark	⓪
Cadillac	
Eldorado & Seville	BL
Deville & Fleetwood	BC
Oldsmobile	
Cutlass Ciera	⓪
88	BB
88 Wagon (Custom Cruiser)	BJ
98	BF
Toronado	BA

⓪ — Not available from manufacturer.

REMOVAL & INSTALLATION

COMPRESSOR

Removal — Deflate system through service valve and disconnect high pressure line at dryer by revolving spring clip and

remove tube assembly. Remove mount screws from relay (if equipped) and allow relay to hang out of way. Remove all electrical connections and support brackets.

Installation — To install, reverse removal procedure. Cycle system and check for leaks. See Fig. 4.

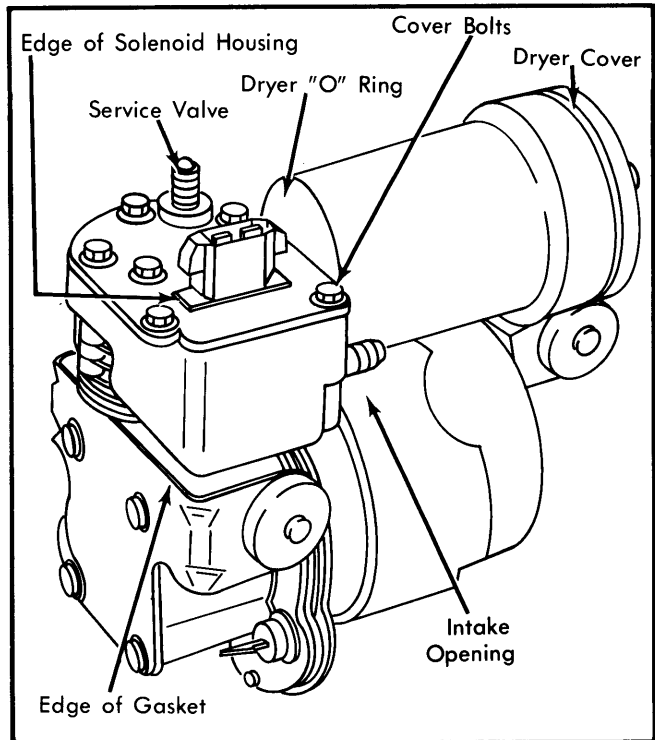

Fig. 4 Compressor Leak Check

AIR DRYER

Removal — Disconnect high pressure line by revolving spring clip and removing tube assembly. Disconnect dryer from compressor by revolving spring clip and slide dryer away from compressor head through its bracket. Remove "O" ring from compressor head.

NOTE — On some vehicles the compressor is mounted on right side of vehicle. Bracket will have to be removed to get dryer out.

Installation — Lubricate "O" ring and install in compressor head. Reverse removal procedures and check system for leaks.

AIR LINE REPAIR

The air line used in system can be repaired by splicing in a coupling at leak area. Use procedures as follows:

- 1) Inflate system to 100 psi.
- 2) Use soap and water solution to locate leak.
- 3) Deflate system through service valve and cut out leaking area.
- 4) Install coupling and tighten to 6 ft. lbs. See Fig. 5.

