

# Rear Suspension

## BUICK, CADILLAC, CHEVROLET, OLDSMOBILE & PONTIAC

Rear Wheel Drive  
(Except Chevette, Corvette & T1000)

### DESCRIPTION

Rear suspension is a link type with coil springs. System uses 4 control arms that attach the rear axle assembly to the frame. A bracket on the axle supports the coil springs. Top of coil spring is positioned under frame rail. Upper arms are attached to top of differential and extend forward to frame. Two shock absorbers are attached to frame and brackets on axle housing. Camaro and Firebird use a torque arm and track bar to secure differential.

### ADJUSTMENT

#### RIDING HEIGHT

See *Riding Height Adjustments and Specifications* in **WHEEL ALIGNMENT** Section.

### REMOVAL & INSTALLATION

#### COIL SPRING

**Removal (Buick, Oldsmobile & Pontiac)** — 1) Hoist rear of vehicle at axle housing and place safety stands under frame rails. Disconnect brake line at axle housing. Disconnect upper control arms at axle housing.

**NOTE** — Models equipped with ELC units use procedures given in Cadillac coil spring removal.

2) Remove shock absorber lower mount. Lower hoist at rear axle. Remove coil spring.

**Installation (Buick, Oldsmobile & Pontiac)** — To install, reverse removal procedures, ensuring that coil spring is positioned as shown in illustration.

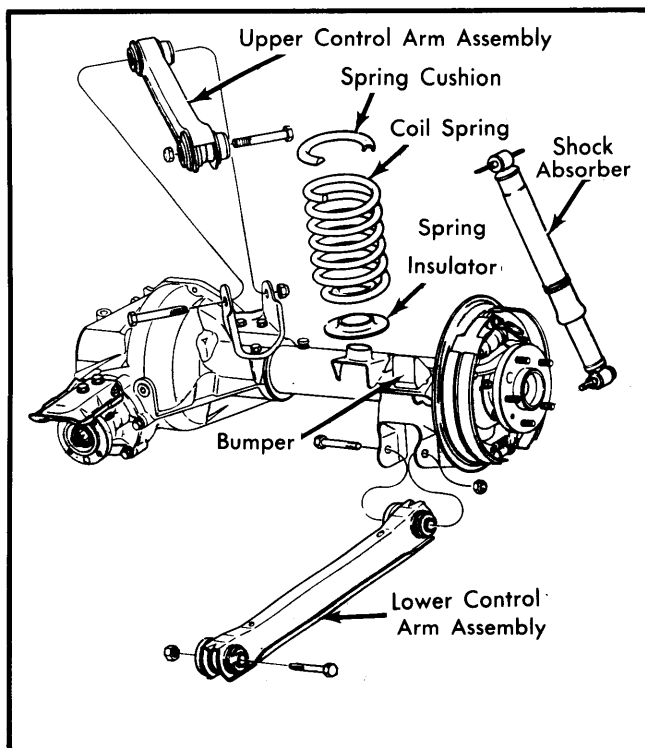

Fig. 1 Rear Coil Spring Suspension

**Removal (Chevrolet)** — 1) Raise vehicle and support rear axle with adjustable lifting device. Disconnect upper control arms from axle. Disconnect stabilizer bar, if equipped. Remove brake hose support bolt to allow for additional axle drop.

**NOTE** — Brake lines do not have to be disconnected to allow for additional drop. Do not lower axle to a point where brake line becomes taut, as damage will result.

2) Remove left side shock absorber lower attachment. Allow axle to travel beyond the fully extended shock with the aid of adjustable lifting device. Lower axle enough to remove spring.

**Installation (Chevrolet)** — To install, reverse removal procedure, ensuring that coil spring is positioned as shown in the illustration.

**Removal (Cadillac)** — 1) Raise vehicle on hoist so rear axle is supported. Remove shock absorbers. If equipped with Electronic Level Control, remove stabilizer bar-to-lower control arm bolts, and remove stabilizer bar. Remove 1 bolt securing junction block to top of differential. Disconnect brake lines from clips on axle.

2) On ELC vehicles, disconnect link from leveling valve arm. Place jackstand under nose of differential carrier and remove lower control arm-to-axle bolts. Disconnect drive shaft from pinion flange and support drive shaft with wire. Remove jack stands.

3) Remove upper arm pivot bolts at axle. Disconnect left side parking brake cable at equalizer. Disconnect cable at frame by removing clip. Slide cable through hole. Remove cable from clip at center of rear crossmember. Disconnect cable at connector located at left of frame. Support both frame rails at rear of frame. Lower axle enough to allow removal of coil springs, and remove springs.

**CAUTION** — Do not allow axle to wind-up as it is lowered, as springs may snap from their seats and cause injury.

**Installation (Cadillac)** — To install, reverse removal procedure ensuring that coil spring is positioned as shown in the illustration.

### UPPER CONTROL ARM

**CAUTION** — Remove and replace 1 control arm at a time to prevent rear axle from rolling or slipping.

**Removal** — 1) If vehicle is equipped with ELC, remove attaching nut that secures height control sensor link to right upper control arm. Position over travel lever in center position.

**NOTE** — On some vehicles, disconnecting lower shock absorber mount will provide clearance for upper control arm removal.

2) Unbolt control arm from upper and lower pivot bolt mounting and remove arm from vehicle.

**Installation** — Reverse removal procedures and tighten pivot bolts with vehicle on ground and at curb height.

## BUICK, CADILLAC, CHEVROLET, OLDSMOBILE & PONTIAC (Cont.)

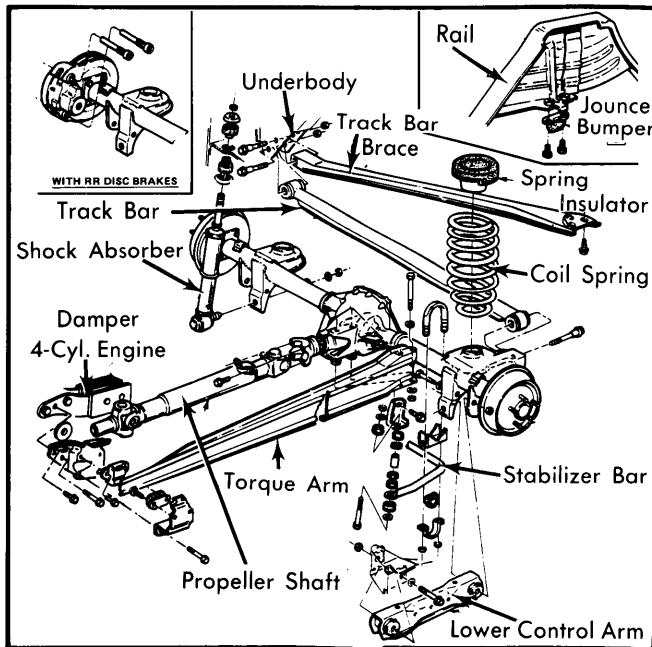

Fig. 2 Rear Suspension Camaro & Firebird

### LOWER CONTROL ARM

**CAUTION** — Remove and replace one control arm at a time to prevent rear axle from rolling or slipping.

**Removal** — Raise and support rear of vehicle. Support axle housing to relieve tension on control arm bolts. Remove lower control arm pivot bolt (below axle housing). Disconnect control arm from frame crossmember and remove assembly.

**NOTE** — If vehicle is equipped with stabilizer bar it will be necessary to remove bar before unbolting arm.

**Installation** — Reverse removal procedures and tighten pivot bolts with vehicle on ground and at curb height.

### TRACK BAR, TORQUE ARM & REAR SPRINGS

**Removal** — 1) Hoist vehicle and support rear axle at curb height position. Remove track bar mounting bolt and nut at rear axle and at body bracket. Remove track bar.

2) Disconnect rear brake hose clips at underbody to allow additional axle drop. Remove right and left shock absorber lower attaching nuts.

3) Remove propeller shaft on vehicles equipped with 4-cylinder engines. Carefully lower rear axle and remove coil springs. Remove torque arm near attaching bolts. Remove front torque arm outer bracket and remove torque arm.

**Installation** — 1) Position torque arm and loosely install rear torque arm bolts. Install front torque arm bracket and tighten to specifications.

2) Torque rear torque arm nuts to specifications. Position springs and insulators in spring seats and raise rear axle until rear axle supports weight of vehicle at normal curb height position.

3) Install shock absorbers to rear axle and torque nuts to specifications. Thoroughly clean track bar-to-axle assembly bolt and nut. Reinstall track bar mounting bolt at axle and torque nut to specifications. Torque track bar to body bracket.

4) Install brake line clips. Install propeller shaft (4-cylinder models). Remove adjustable lifting device and lower vehicle.

### TIGHTENING SPECIFICATIONS

Application	Ft. Lbs. (N·m)
Upper Control Arm-to-Frame	
Buick	
Regal .....	70 (95)
Electra & LeSabre .....	95 (130)
Cadillac .....	90 (122)
Chevrolet	
Caprice & Impala .....	70 (95)
El Camino, Malibu & Monte Carlo .....	73 (97)
Oldsmobile	
Cutlass .....	70 (95)
88 & 98 .....	95 (130)
Pontiac .....	70 (95)
Lower Control Arm-to-Axle	
Buick	
Regal .....	80 (109)
Electra & LeSabre .....	95 (130)
Cadillac .....	90 (122)
Chevrolet	
Camaro .....	68 (93)
Caprice & Impala .....	92 (125)
El Camino, Malibu & Monte Carlo .....	70 (95)
Oldsmobile	
Cutlass .....	80 (109)
88 & 98 .....	120 (165)
Pontiac	
Bonneville & Grand Prix .....	70 (95)
Firebird .....	68 (93)
Shock Absorber (Upper Attachment)	
Buick, Cadillac & Oldsmobile .....	20 (27)
Chevrolet	
All Models .....	12 (17)
Pontiac	
All Models (Except Firebird) .....	20 (27)
Firebird .....	12 (16)
Shock Absorber (Lower Attachment)	
Buick, Cadillac & Oldsmobile .....	65 (88)
Chevrolet & Pontiac	
Except Camaro & Firebird .....	65 (88)
Camaro & Firebird .....	70 (95)
Stabilizer-to-Control Arm	
Buick, Cadillac & Oldsmobile .....	50 (68)
Chevrolet	
Camaro .....	12 (17)
Caprice & Impala .....	20 (27)
El Camino, Malibu & Monte Carlo .....	37 (50)
Pontiac (Except Firebird) .....	42 (57)
Firebird .....	12 (17)
Track Bar	
Camaro & Firebird .....	93 (126)
Torque Arm Bracket	
Camaro & Firebird .....	20 (27)
Rear Torque Arm Nuts	
Camaro & Firebird .....	100 (135)