

FORD MOTOR CO.

Ford & Mercury
Lincoln Town Car & Mark VI

DESCRIPTION

The rear axle housing is suspended from the frame by 2 upper control arms which control side-to-side movement, and 2 lower control arms which control front-to-rear movement. Each coil spring is mounted between a lower and upper seat. The shock absorbers are attached to the upper spring seat, or the upper shock brackets at the frame, and at the lower shock brackets welded to the axle tube.

ADJUSTMENT

RIDING HEIGHT

See *Riding Height Adjustment and Specifications* in **WHEEL ALIGNMENT** Section.

PROPELLER SHAFT PINION ANGLE

See *Propeller Shaft Alignment* in **DRIVE AXLES** Section.

REMOVAL & INSTALLATION

COIL SPRING

NOTE — If one spring must be replaced, both springs must be replaced. If equipped with stabilizer bar, remove as outlined.

Removal (Ford, Mercury, Lincoln and Mark VI) — Place hoist under axle housing and raise vehicle. Place safety stands under frame side rails. Disconnect lower shock absorber mountings. Unsnap right side parking brake cable from retainer. Lower hoist and axle housing until springs are released. Remove springs and insulators from vehicle.

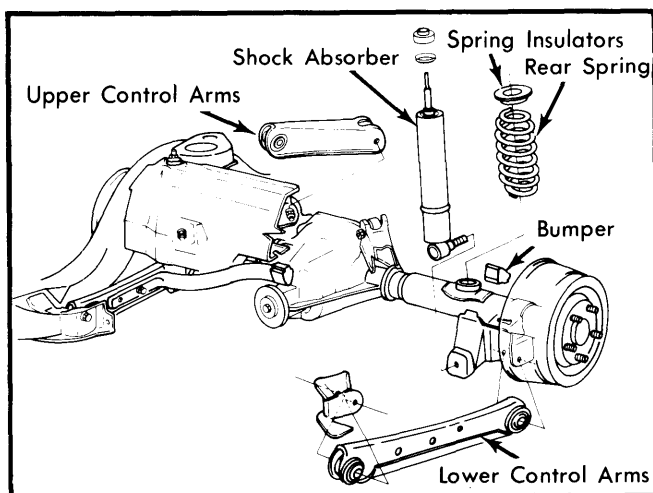

Fig. 1 Coil Spring Type Rear Suspension Assembly
(Ford, Mercury, Lincoln & Mark VI)

Installation (Ford, Mercury, Lincoln and Mark VI) — Reverse removal procedure and note following: Ensure coil spring insulator is installed between upper end of spring and frame seat.

Removal (All Other Models) — Raise vehicle and support at rear body crossmember. Lower hoist until shock absorbers are fully extended. Rear axle must be supported by stands. Place transmission jack under lower arm and remove attaching bolts and nuts. Lower transmission jack slowly to release spring load. Remove coil spring and insulator.

Installation (All Other Models) — 1) Place upper spring insulator on top of spring. Place lower spring insulator on lower arm (if equipped). On Thunderbird and XR-7, place internal damper into spring. Position spring on lower seat so that pigtail is at rear and pointing toward left side of vehicle.

2) Slowly raise transmission jack until arm is in position and install new rear pivot bolt with nut facing out. Lower jack and raise axle to curb height. Tighten pivot bolt. Remove supports and lower vehicle.

LOWER CONTROL ARM

NOTE — When one lower control arm requires replacement, both lower arms must be replaced. If both upper and lower arms are removed at the same time, coil springs must also be removed.

Removal (Ford, Mercury, Lincoln and Mark VI) — Remove stabilizer bar, if equipped. Raise vehicle on hoist and place safety stands under frame side rails. Lower hoist until shocks are fully extended. Support axle under differential pinion nose, and under axle. Remove pivot bolt from axle bracket, and disengage lower arm from bracket. Remove pivot bolt from frame bracket and remove lower arm.

Removal (All Other Models) — Remove stabilizer bar, if equipped. Raise vehicle and support at rear body crossmember. Support axle and lower hoist until shocks are fully extended. Place transmission jack under lower arm rear pivot bolt and remove bolt and nut. Lower transmission jack slowly until spring can be removed. Remove lower arm front pivot bolt and remove lower arm.

Installation (All Models) — Reverse removal procedure, noting the following: Do not torque bolts until both are in place and axle is raised to riding height.

UPPER CONTROL ARM

NOTE — When one upper control arm requires replacement, both upper arms must be replaced.

Removal (Ford, Mercury, Lincoln and Mark VI) — Raise vehicle and place safety stands under frame side rails. Support axle. Lower axle and support under differential pinion nose as well as under axle. Disconnect parking brake cable from upper arm retainer. Remove upper arm-to-axle housing attaching bolt and nut and disconnect arm from housing. Remove upper arm-to-frame bracket retaining nut and bolt and remove upper arm.

FORD MOTOR CO. (Cont.)

Installation (Ford, Mercury, Lincoln and Mark VI) – Reverse removal procedure and note following: Install new attaching bolts and nuts, with bolts facing front of vehicle.

Removal (All Other Models) – Raise vehicle on hoist and support at rear body crossmember. Remove upper arm rear pivot bolt and nut. Remove front pivot bolt and nut. Remove upper arm.

Installation (All Other Models) – Reverse removal procedure and note the following: Install new pivots bolts and nuts, with nuts facing inboard.

Installation (Ford, Mercury, Lincoln and Mark VI) – Reverse removal procedure noting following: Install new bolts and nuts. Color coded end of stabilizer bar goes on right side of vehicle.

Removal (All Other Models) – Raise vehicle on hoist. Remove 4 bolts, nuts and spacers attaching stabilizer bar to lower arm brackets. Remove stabilizer bar.

Installation (All Other Models) – Reverse removal procedure and note following: Install new bolts and nuts. Color coded end of bar goes on right side of vehicle. Inspect for adequate clearance between lower arm and stabilizer bar.

STABILIZER BAR

Removal (Ford, Mercury, Lincoln and Mark VI) – Raise vehicle on hoist and support with safety stands under frame side rails. Lower hoist and axle housing until shocks are fully extended. Remove 4 bolts, nuts and spacers attaching stabilizer bar to lower arm. Remove stabilizer bar.

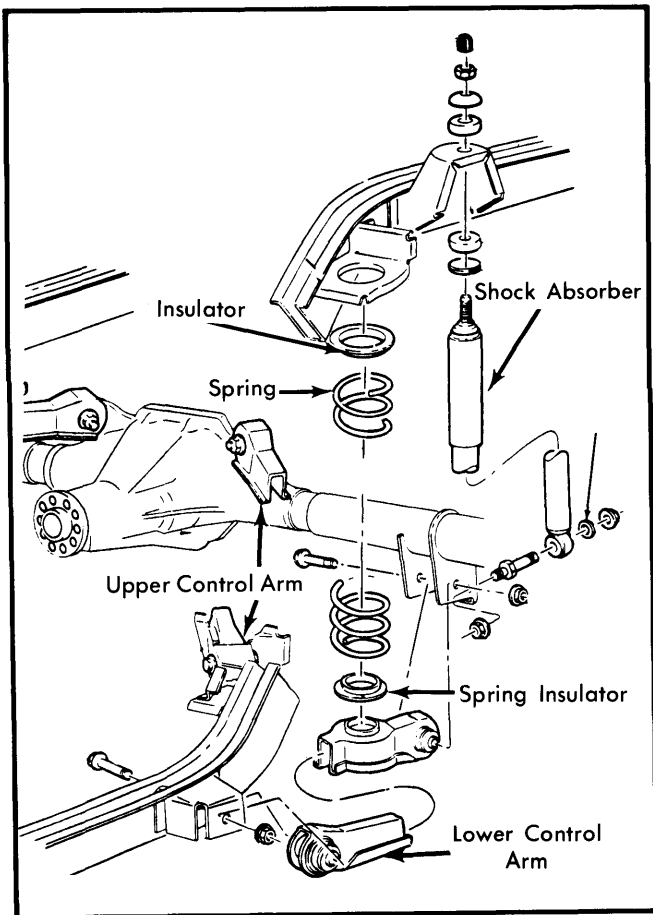

Fig. 2 View of Rear Suspension on Capri, Mustang, Fairmont, Zephyr, Granada and Cougar (Thunderbird and XR7 Similar)

TIGHTENING SPECIFICATIONS

Application	Ft. Lbs. (N·m)
Shock Absorber Upper	
Ford, Mercury, Lincoln, Mark VI	14-26 (19-35)
Capri, Mustang, Fairmont, Zephyr, Thunderbird, Cougar, Granada, XR7	24-26 (33-35)
Shock Absorber Lower	
Ford, Mercury, Lincoln, Mark VI	55-85 (75-116)
Capri, Mustang, Fairmont, Zephyr, Thunderbird, Cougar, Granada, XR7	60-65 (82-88)
Upper Arm-to-Axle	
Ford, Mercury, Lincoln, Mark VI	103-133 (140-181)
Capri, Mustang, Fairmont, Zephyr, Thunderbird, Cougar, Granada, XR7	90-100 (122-136)
Lower Arm-to-Axle	
Ford, Mercury, Lincoln, Mark VI	103-133 (140-181)
Capri, Mustang, Fairmont, Zephyr, Thunderbird, Cougar, Granada, XR7	90-100 (122-136)
Upper Arm-to-Frame	
Ford, Mercury, Lincoln, Mark VI	120-150 (163-204)
Capri, Mustang, Fairmont, Zephyr, Thunderbird, Cougar, Granada, XR7	100-110 (136-150)
Lower Arm-to-Frame	
Ford, Mercury, Lincoln, Mark VI	120-150 (163-204)
Capri, Mustang, Fairmont, Zephyr, Thunderbird, Cougar, Granada, XR7	100-110 (136-150)
Stabilizer Bar, Rear	
Ford, Mercury, Lincoln, Mark VI	70-92 (95-125)
Stabilizer Bar-to-Lower Arm	
Capri, Mustang, Fairmont, Zephyr, Thunderbird, Cougar, Granada, XR7	45-50 (61-88)
Shock Absorber Clevis Bolt	
Thunderbird, XR7	55-60 (75-82)