

CHRYSLER CORP. SINGLE PISTON DISC

Chrysler Corp. (All Models)

DESCRIPTION

The disc brake assembly consists of a caliper, disc pads, splash shield, adapter, and rotor. As the brake pedal is depressed, hydraulic pressure is applied against the piston located in the caliper assembly. This force is transmitted to the inboard disc pads and against the braking surfaces of the rotor. As the forces increase against the inboard side, the caliper moves inward, providing full clamping force on the rotor.

Calipers are installed 2 ways. On Aries, Horizon, Omni and Reliant models, a floating caliper is mounted, using 2 steel guide pins installed through 2 rubber bushings. On all other models, a sliding caliper is mounted on 2 machined pads and held in position by 2 retaining clips and anti-rattle springs.

ADJUSTMENT

SERVICE BRAKES

Disc brakes are self-adjusting. Caliper piston seals are designed to retract pistons just enough to allow brake lining to lightly brush disc without any drag.

SERVICING

BLEEDING SYSTEM

See *Hydraulic Brake Bleeding* in this section.

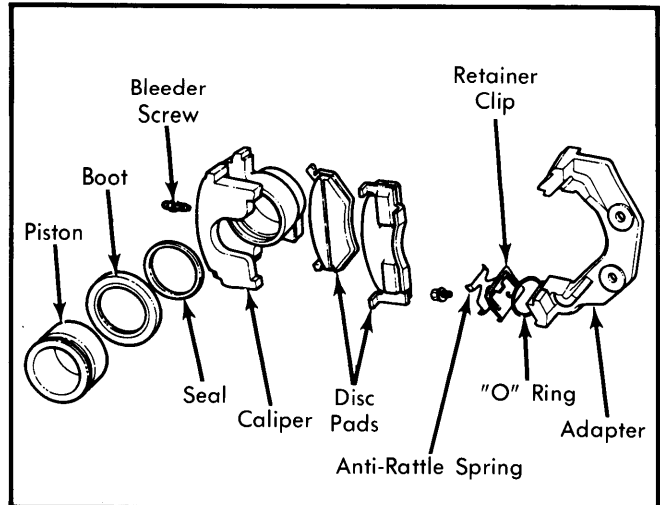

Fig. 1 Exploded View of Sliding Caliper Assembly (All Models Except Aries, Horizon, Omni & Reliant)

DISC PAD INSPECTION

Inspect condition of disc pads any time wheels are removed. When a shoe and lining assembly is worn to a thickness of approximately $\frac{5}{16}$ " it should be replaced.

DISC PAD REPLACEMENT

Removal (Exc. Aries, Horizon, Omni & Reliant) — Raise and support front of vehicle. Remove wheel and tire. Remove retaining clips and anti-rattle springs. Slowly slide caliper out and away from rotor. Remove outer pad by prying between pad and caliper fingers. Support caliper with wire to prevent damage to brake hose. Remove inner pad.

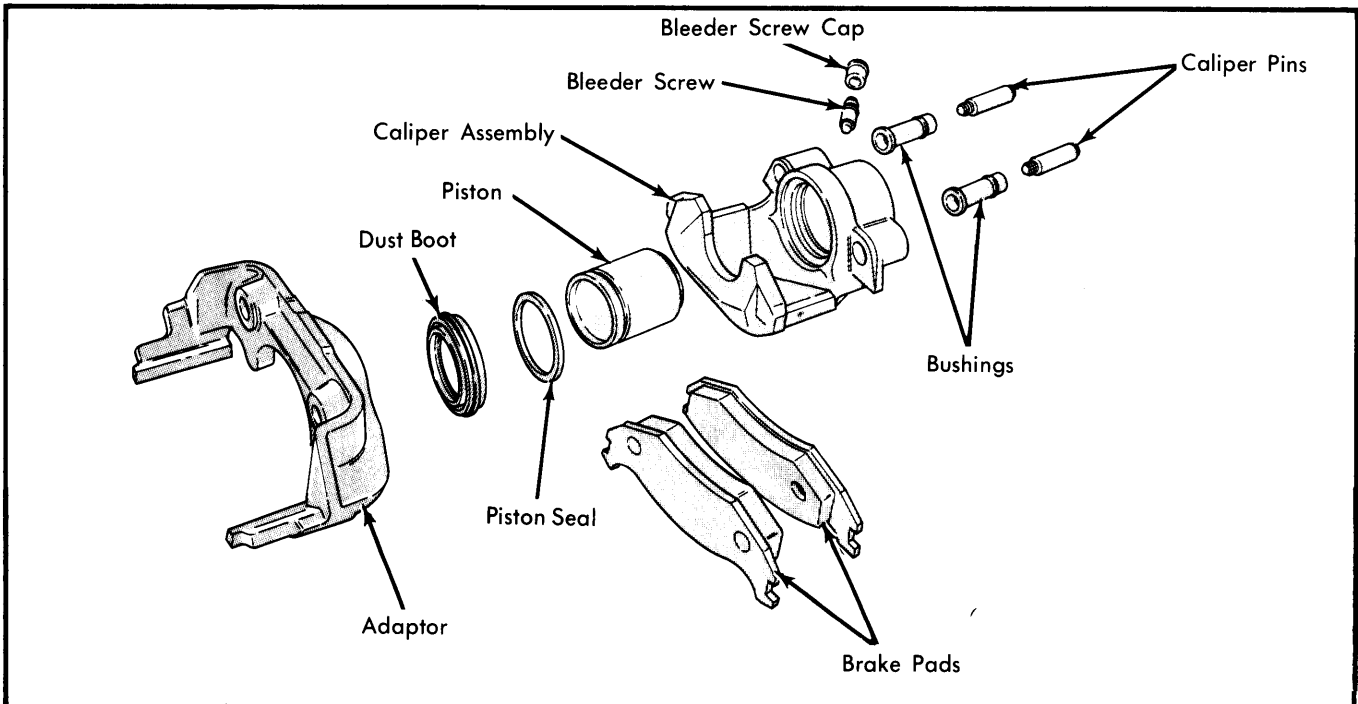

Fig. 2 Exploded View of Floating Caliper Assembly (Horizon & Omni Shown, Aries & Reliant Similar)

CHRYSLER CORP. SINGLE PISTON DISC (Cont.)

Installation (Exc. Aries, Horizon, Omni & Reliant) – 1) Slowly and carefully push piston into bore of caliper until bottomed. Slide new outer disc pad into recess of caliper.

NOTE – No free play between pad flanges and caliper fingers should exist. If free play is evident by vertical pad movement after installation, remove pad and bend flanges to create slight interference fit to eliminate free play.

2) Position inner pad in position on adapter with pad flanges in adapter machined guides. Slowly slide caliper assembly into position in adapter and over rotor. Align caliper on machined guides of adapter.

CAUTION – Be careful not to pull dust boot from its groove as piston and boot slide over inner pad.

3) Install anti-rattle springs and retaining clips and tighten retaining screws. Make sure inner anti-rattle spring is installed on top of retaining spring plate.

4) Pump brake pedal several times until a firm brake pedal is obtained. Refill master cylinder if necessary. Bleed brake system if necessary. Install wheel and tire assembly and lower vehicle.

Removal (Aries, Horizon, Omni & Reliant) – 1) Raise and support front of vehicle and remove wheel and tire. On Horizon and Omni, remove caliper guide pins and anti-rattle spring. See Fig. 3.

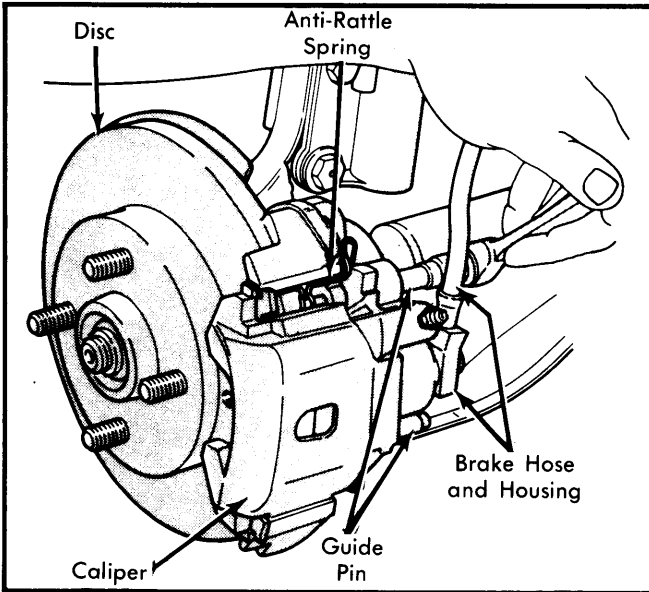

Fig. 3 Removing or Installing Caliper Guide Pins (Omni and Horizon)

2) On Aries and Reliant, remove hold-down spring from caliper assembly by pushing in and outward at center of spring. Loosen but do not remove caliper guide pins until caliper is free. Remove guide pins only if bushings or sleeves are to be replaced.

3) On all models, remove caliper by slowly sliding it outward away from rotor. Support caliper firmly to prevent damage to brake hose. On Horizon and Omni, slide outer pad from adapter. Slide rotor off drive axle hub and studs. Slide inner pad out of adapter.

4) On Aries and Reliant, remove shoe from caliper by pulling away from piston. Lift outer pad from adapter.

Installation (Aries, Horizon, Omni & Reliant) – 1) On Aires and Reliant, install new inner pad in caliper, entering retainer in bore in piston. Position outer pad on adapter.

2) On Horizon and Omni, slowly and carefully push piston back into caliper bore until bottomed. Slide new inner pad into position in adapter and install rotor over studs on drive hub.

3) On Horizon and Omni, position outer pad in adapter. On all models, carefully lower caliper over rotor and outer pad. Insert guide pins through bushings, caliper and adapter.

4) Press in on pins and thread into adapter, using care not to cross threads. Tighten to specifications. On Horizon and Omni, install anti-rattle spring with end loop inboard on caliper lug.

5) On Aries and Reliant, install hold-down spring. On all models, pump brake pedal several times until a firm pedal is obtained. Refill master cylinder and bleed brake system if necessary.

6) Install wheel and tire and tighten stud nuts by skipping every other nut going around. Tighten first to $\frac{1}{2}$ of final specification, then repeat sequence to full specification. Road test vehicle and seat pads by making several stops.

ROTOR SERVICING

Lateral Runout – Tighten wheel bearings until all end play is eliminated. Attach dial indicator to suspension such that dial pointer contacts rotor face approximately one inch from outer edge. Turn rotor through one complete revolution, checking indicator as rotor moves. If runout exceeds specifications, refinish or replace rotor assembly as necessary.

Parallelism – Measure thickness of rotor at 12 points around rotor. Make all measurements one inch from edge of rotor. If rotor does not meet specifications, refinish or replace rotor assembly as necessary.

REMOVAL & INSTALLATION

BRAKE CALIPER

Caliper removal and installation procedures are the same as for disc pad assembly replacement, except that it will be necessary to disconnect brake hose from caliper. See *Disc Pad Replacement*.

HUB & ROTOR

Removal (Exc. Aries, Horizon, Omni & Reliant) – Raise and support front of vehicle and remove tire and wheel. Remove caliper assembly and support out of the way to prevent damage to brake hose. Remove grease cap, cotter pin, nut lock, thrust washer and outer wheel bearing. Slide hub and rotor from wheel spindle.

Removal (Aries, Horizon, Omni & Reliant) – Raise and support front of vehicle. Remove wheel and tire. Remove caliper assembly as outlined in *Disc Pad Replacement Section*. Suspend caliper from wire hook to avoid damage to brake line. Remove rotor from drive hub studs.

CHRYSLER CORP. SINGLE PISTON DISC (Cont.)

Installation (All Models) – 1) On Aries, Horizon, Omni and Reliant, position rotor onto drive hub studs. On all other models, slide rotor and hub assembly onto spindle. Install outer wheel bearing, thrust washer and nut. Tighten nut to 240-300 INCH Lbs. while rotating hub.

2) Back off nut to release all preload, then tighten nut finger tight. Position lock on nut, then install cotter pin and grease cap. On all models, clean both sides of rotor with alcohol or suitable solvent, then install caliper assembly.

OVERHAUL

Disassembly – 1) With caliper removed from rotor (brake hose still attached), carefully depress brake pedal to hydraulically force piston out of bore. Pedal will fall away when piston has passed bore opening. Support brake pedal to any position below first inch of travel to prevent fluid loss.

CAUTION – Chrysler Corp. recommends that compressed air not be used to remove piston from caliper.

2) Disconnect brake hose from caliper and mount caliper in a padded vise. Do not clamp unit too tightly. Remove dust boot, and using a small wooden or plastic stick, pry seal from caliper bore groove. On Aries, Horizon, Omni and Reliant models, press out inner and outer bushings from bore. On Aries and Reliant, discard bushings and Teflon sleeves.

NOTE – Do not use a screwdriver or other metal tool to remove seal from caliper, because of possibility of scratching piston bore or burring edges of seal groove.

Cleaning & Inspection – Clean all components, using denatured alcohol, and air dry. Blow out all passages and bores. Inspect piston and bore for scoring or pitting. Clean light scoring or corrosion with crocus cloth. Bores with deep scoring may be honed, providing diameter of bore is not increased more than .001". If specification is exceeded, replace caliper.

Reassembly – 1) Dip new piston seal in clean brake fluid and install in groove in bore. Position seal at one area in groove, and with clean fingers, gently work seal into groove until seated. Coat new piston boot with clean brake fluid, leaving a generous amount inside boot.

2) For Aries, Horizon, Omni and Reliant, position dust boot over piston. Install piston into bore, pushing it past piston seal, until it bottoms in bore. For all other models, position boot in bore. Using a hammer and Tool C-4682 for Horizon and Omni, Tool C-4689 for all other models and handle C-4171 for all models, drive boot in position in bore.

3) On Aries, Horizon, Omni and Reliant, compress flange of new inner and outer guide pin bushing with fingers. Work into position by pressing in on bushings, using fingers or plastic trim stick until seated. On Aries and Reliant, remove Teflon sleeves from guide pin bushings before installing bushings into caliper. After bushings are installed, reinstall Teflon sleeves into bushings.

NOTE – Be sure bushing flanges extend over caliper casting evenly on both sides.

5) On all models except Aries, Horizon, Omni and Reliant, use a plastic trim stick to work piston into boot. Carefully push piston into bore until bottomed. Make sure boot is in piston groove. On all models, install brake hose to caliper using new seal washers.

TIGHTENING SPECIFICATIONS

Application	Ft. Lbs.
Brake Hose-to-Caliper	19-29
Adapter Mounting Bolts	
Aries, Horizon, Omni & Reliant	70-100
All Others	95-125
Guide Pins	
Aries & Reliant	18-22
Horizon & Omni	25-40

Application	INCH Lbs.
Caliper Retainer Plate Screws	170-260
Splash Shield Mounting Bolts	
Aries, Horizon, Omni & Reliant	200-300
All Others	160 Min.
Bleeder Screw	
Aries, Horizon, Omni & Reliant	60-100
All others	80-170

DISC BRAKE ROTOR SPECIFICATIONS

Application	Disc Diameter	Lateral Runout	Parallelism	Original Thickness	Minimum Refinish Thickness	Discard Thickness
Aries & Reliant	9.28"	.005"	.0005"	.930-.940"	.912"	.882"
Horizon & Omni	9.00"	.005"	.0005"	.490-.505"	.461"	.431"
All Other Models	10.98"ⓐ	.004"	.0005"	1.000-1.010"	.970"	.940"

ⓐPolice and Taxi 11.75" Disc.