

Power Steering

CHRYSLER CORP.

Chrysler Corp.

DESCRIPTION

Power steering gear consists of a gear housing containing a sector shaft with sector gear, a power piston with gear teeth broached into side of piston which is in constant mesh with gear shaft sector, and a worm shaft connecting the steering wheel to power piston through a U-joint type coupling. The worm shaft is geared to piston through recirculating ball contact. Steering valve, mounted on top of steering gear, directs the flow of fluid through system. Fluid is supplied to steering gear by an engine driven constant displacement pump through a pressure hose. Oil is returned to pump reservoir from steering gear through a return hose.

LUBRICATION, TROUBLE SHOOTING & TESTING

See Power Steering General Servicing in this section.

ADJUSTMENT

SECTOR SHAFT PRELOAD

Disconnect center link from steering gear arm. Start engine and run at idle. Turn steering wheel from lock-to-lock, counting number of turns, and then turn back halfway to center position. Loosen adjusting screw until backlash is just felt in steering gear arm. Tighten adjusting screw until backlash just disappears, then turn adjusting screw $\frac{3}{8}$ - $\frac{1}{2}$ turn more. Tighten lock nut.

VALVE BODY CENTERING

1) Loosen both valve body screws and then retighten to 7 ft. lbs. to prevent valve leakage during valve centering. Start engine, if unit is self-steering, tap the valve up or down to correct. Turn steering wheel to expel air from system and refill reservoir as required.

CAUTION — Do not turn hard against steering gear stops. High pressure may blow out "O" rings since valve body screws have not been finally tightened.

2) With steering wheel in straight ahead position, start and stop engine several times, tapping the valve body up and down as required until there is no movement of steering wheel when engine is started or stopped. The valve is now centered. Tighten two screws attaching valve body to housing.

REMOVAL & INSTALLATION

STEERING GEAR

Removal — 1) To avoid damage to energy absorbing steering column, it is recommended that steering column be completely detached from floor and instrument panel before steering gear is removed.

NOTE — See Steering Columns in this section for removal and installation procedures.

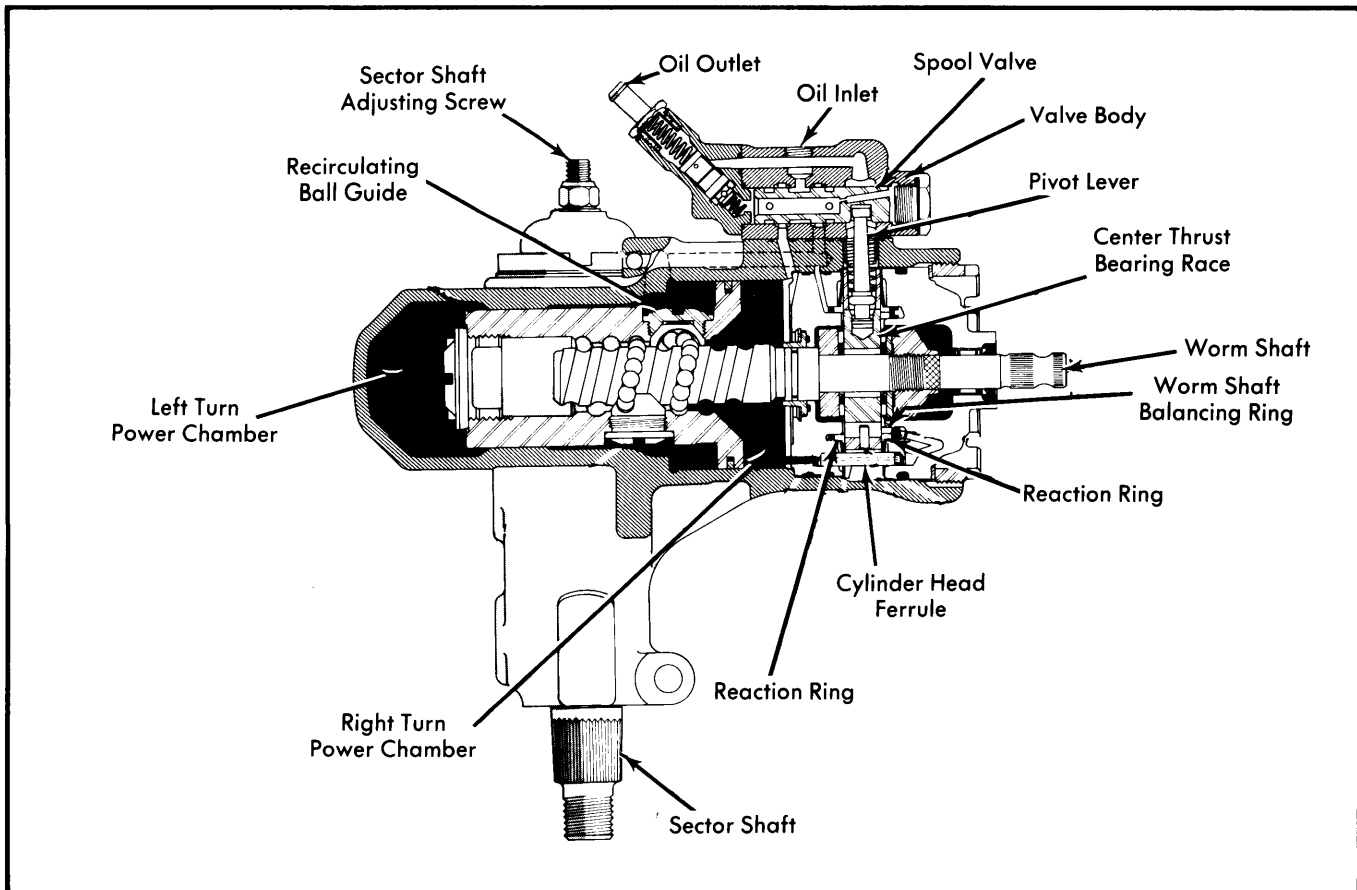

Fig. 1 Power Steering Gear

CHRYSLER CORP. (Cont.)

2) Remove steering column and disconnect power steering pressure and return hoses at centering valve on gear. Tie ends of hoses above pump level to avoid loss of fluid.

3) From under vehicle, remove steering arm retaining nut and lock washer. Remove steering arm with suitable puller (C-4150). Remove gear-to-frame retaining bolts and remove gear.

Installation — Reverse removal procedures and note the following: Place steering wheel in straight ahead position. Rotate worm shaft by hand and center sector shaft to midpoint of its travel. Align master serration on sector shaft with splines on steering arm.

OVERHAUL

STEERING GEAR

Disassembly — 1) Clean exterior of gear housing and install it in a suitable holding fixture. Drain steering gear through pressure and return connections by turning steering worm shaft lock-to-lock several times. Remove valve body attaching screws, valve body and the three "O" rings. Remove pivot lever and spring.

CAUTION — Use care not to collapse slotted end of valve lever as this will destroy bearing tolerances of spherical head.

2) Loosen sector shaft adjusting screw lock nut and remove sector shaft cover spanner nut with a suitable tool (C-3988). Rotate worm shaft to position sector shaft sector teeth at center of piston travel. Loosen steering power train retaining nut with a suitable tool (C-3989).

3) Turn worm shaft to full left turn position to compress power train parts. Remove power train retaining nut and housing head tang washer. With power train firmly compressed, pry against piston teeth with a screwdriver using sector shaft gear teeth as a fulcrum, and remove complete power train.

NOTE — Cylinder head, center race, spacer assembly and housing head must be maintained in close contact with each other.

4) Place power train vertically in soft jawed vise. Remove housing head from worm shaft and "O" ring from groove in housing head. Remove reaction seal from groove in face of housing head with compressed air directed into ferrule chamber. Remove reaction spring, reaction ring, worm balancing ring and spacer.

NOTE — If worm shaft seal is to be replaced, replace seal with housing head disassembled in steering gear housing.

5) Hold worm shaft from turning, then turn nut to release staked portions from knurled section and remove nut. Wire brush knurled sections to remove metal chips, then blow out nut and worm shaft to remove any metal particles. Remove upper thrust bearing race (thin) and upper thrust bearing. Remove center bearing race, then lower thrust bearing and bearing race (thick). Remove lower reaction ring and spring, then cylinder head assembly.

6) Remove "O" rings from outer grooves in cylinder head. Remove reaction "O" ring from groove in face of cylinder head by directing air pressure into oil hole between the two "O" ring grooves. Remove snap ring, sleeve and rectangular oil seal ring from cylinder head counterbore. Test operation of worm shaft. Torque required to rotate worm shaft throughout its travel in or out of piston should not exceed 1 1/2 INCH lbs.

NOTE — Worm and piston are serviced as an assembly and should not be disassembled.

7) Test for excessive side play with piston held in vise (rack teeth up) and worm in its approximate center of travel. Vertical side play measured at a point 2 5/16" from piston flange should not exceed .008" when end of worm is lifted with a force of one pound.

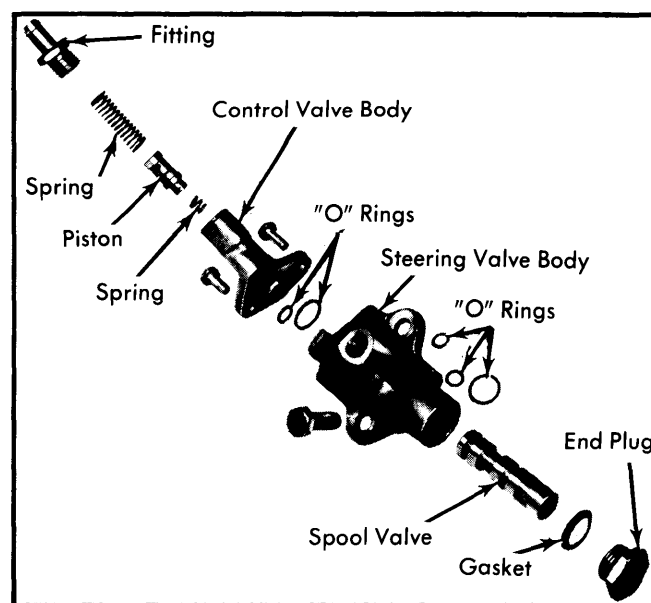

Fig. 2 Valve Body

Reassembly — 1) Inspect condition of Teflon sealing ring. If replacement is necessary, either Teflon or cast iron piston rings may be used. To install cast iron piston ring, install new sealing "O" ring and slide new piston ring into place in piston groove, then place piston and ring assembly in a holding fixture (C-3676) with lower part of piston and ring resting on land of fixture. Press down on piston to seat ring in piston groove, forcing open ends of ring out for ease of locking ring ends.

2) To install new Teflon piston ring, install new rectangular seal ring making sure ring is not twisted. Stretch Teflon ring as little as possible and slide ring into piston groove. Re-size Teflon ring by using a piston ring compressor.

3) Place piston assembly in vertical position (worm shaft up) in a soft jawed vise. Inspect worm shaft teflon seal for nicks and voids. To replace seal, cut and remove oil seal. Replacement seal is split and should be installed using multi-purpose grease to hold seal centered on shaft. Make sure end gap is closed. Inspect cylinder head ferrule oil passage for obstructions and lands for burrs. Lubricate two large "O" rings and install them in cylinder head grooves. Install worm sleeve seal, sleeve and snap ring (if removed). Make sure snap ring is seated in groove. Install lower reaction seal ("O" ring) in cylinder head groove.

CHRYSLER CORP. (Cont.)

4) Slide cylinder head assembly (ferrule up) on worm shaft. Make sure gap on worm shaft seal ring is closed to avoid damaging ring as cylinder head moves against piston flange. Lubricate with power steering fluid, and install parts in the following manner: Lower thrust bearing race (thick), lower thrust bearing, lower reaction spring (small hole over ferrule), lower reaction ring (flange up so ring protrudes through reaction spring and contacts reaction "O" ring in cylinder head), center bearing race, upper thrust bearing, upper thrust bearing race (thin). Start worm shaft thrust bearing adjusting nut but do not tighten.

5) Turn worm shaft clockwise one-half turn. Hold worm shaft in this position with splined nut, then tighten nut to 50 ft. lbs. to prestretch threads. Loosen adjusting nut. Place several turns of cord around center bearing race. Make a loop in one end of cord, and attach a suitable spring scale to loop. Pulling cord will cause bearing race to rotate. Retighten worm bearing adjusting nut while pulling on cord with scale. When adjusting nut is tightened properly, reading on scale should be 16-24 ozs. (20 ozs. preferred while race is turning).

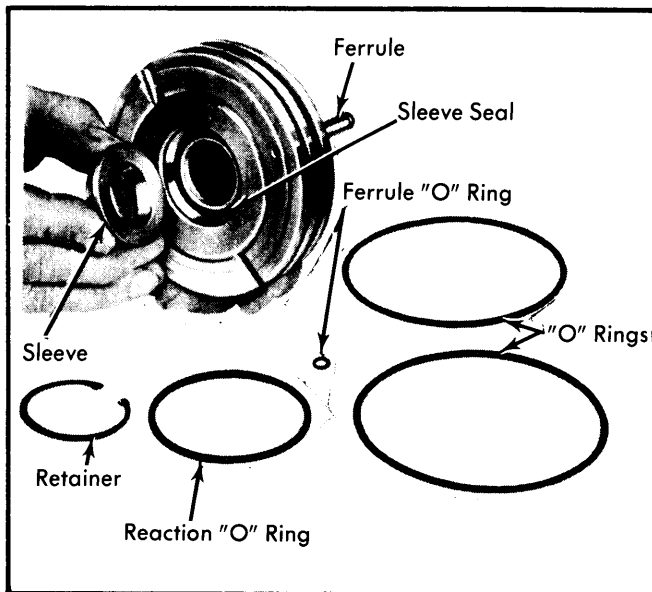

Fig. 3 Cylinder Head Oil Seals

6) Stake upper part of worm shaft adjusting nut into knurled area of shaft. Hold a $\frac{1}{4}$ " flat end punch on centerline of wormshaft end at a slight angle to nut flange. Strike punch a sharp blow with a hammer and test preload. If adjusting nut moved during staking operation, it can be corrected by striking the nut a glancing blow in the direction required to regain proper preload. After testing for proper preload, stake the nut at 3 more locations, 90° apart around upper part of nut. To test total staking, apply 20 ft. lbs. of torque in each direction. If nut does not move, staking operation is correct.

7) Position spacer assembly over center race, engaging dowel pin of spacer in slot of race, and slot of spacer entered over cylinder head ferrule. This aligns valve pivot lever hole in center bearing race with valve pivot lever hole in center bearing spacer assembly.

NOTE — The small "O" ring for the ferrule groove should not be installed until after the upper reaction spring and spacer have been installed.

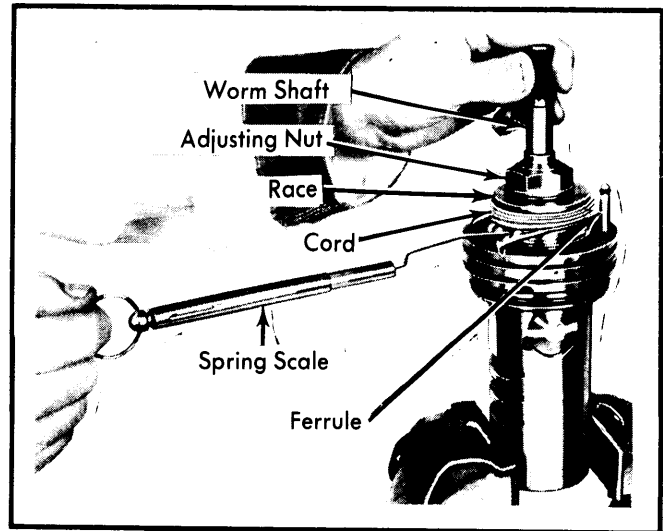

Fig. 4 Measuring Center Bearing Preload

8) Install upper reaction ring on center race and spacer with flange against spacer. Install upper reaction spring over reaction ring with cylinder head ferrule through hole in reaction spring. Install worm balancing ring (without flange) inside upper reaction ring. Lubricate ferrule "O" ring with Vaseline and install in groove on cylinder head ferrule. If oil seal was removed from housing head, install new seal with lip of seal toward bearing. Drive seal in until suitable installation tool (C-3650) bottoms on support. Lubricate and install reaction seal in groove in face of housing head with flat side of seal out. Install "O" ring in groove on housing head.

9) Slide housing head over worm shaft carefully engaging cylinder head ferrule and "O" ring. Make sure reaction rings enter circular groove in housing head. Install power train in gear housing. If it is necessary to replace gear shaft needle bearings, remove adjusting screw from sector shaft cover by turning adjusting screw clockwise until shaft becomes disengaged from cover, then slide adjusting screw out of "T" slot in end of shaft.

10) Do not remove sector shaft oil seal unless replacement is necessary. To remove oil seal, pry out grease retainer, remove oil seal snap ring and seal retainer, then pry out oil seal. Use care to avoid scratching seal bore. Lubricate new seal with power steering fluid and position seal with lip toward housing. Drive seal into housing and install seal retainer and snap ring with ring identification stamp to outside. Fill housing cavity with multi-purpose grease and position grease retainer on housing bore with metal side out. Drive retainer into housing until shoulder of suitable adapter (SP-5148) contacts gear housing.

11) Insert sector shaft and adjusting screw into cover, and using an Allen wrench through threaded hole in cover, turn screw counterclockwise to pull shaft completely into cover. Install aluminum gasket, date tag and lock nut, but do not tighten. Install "O" ring on undercut shelf of cover.

12) Lubricate power train bore of housing and install power train assembly. To keep reaction rings from coming out of their grooves, keep worm turned fully counterclockwise. Piston teeth must be facing to the right and valve lever hole in center race and spacer must be in the "up" position. Ensure that cylinder head is bottomed on housing shoulder. Align valve lever

CHRYSLER CORP. (Cont.)

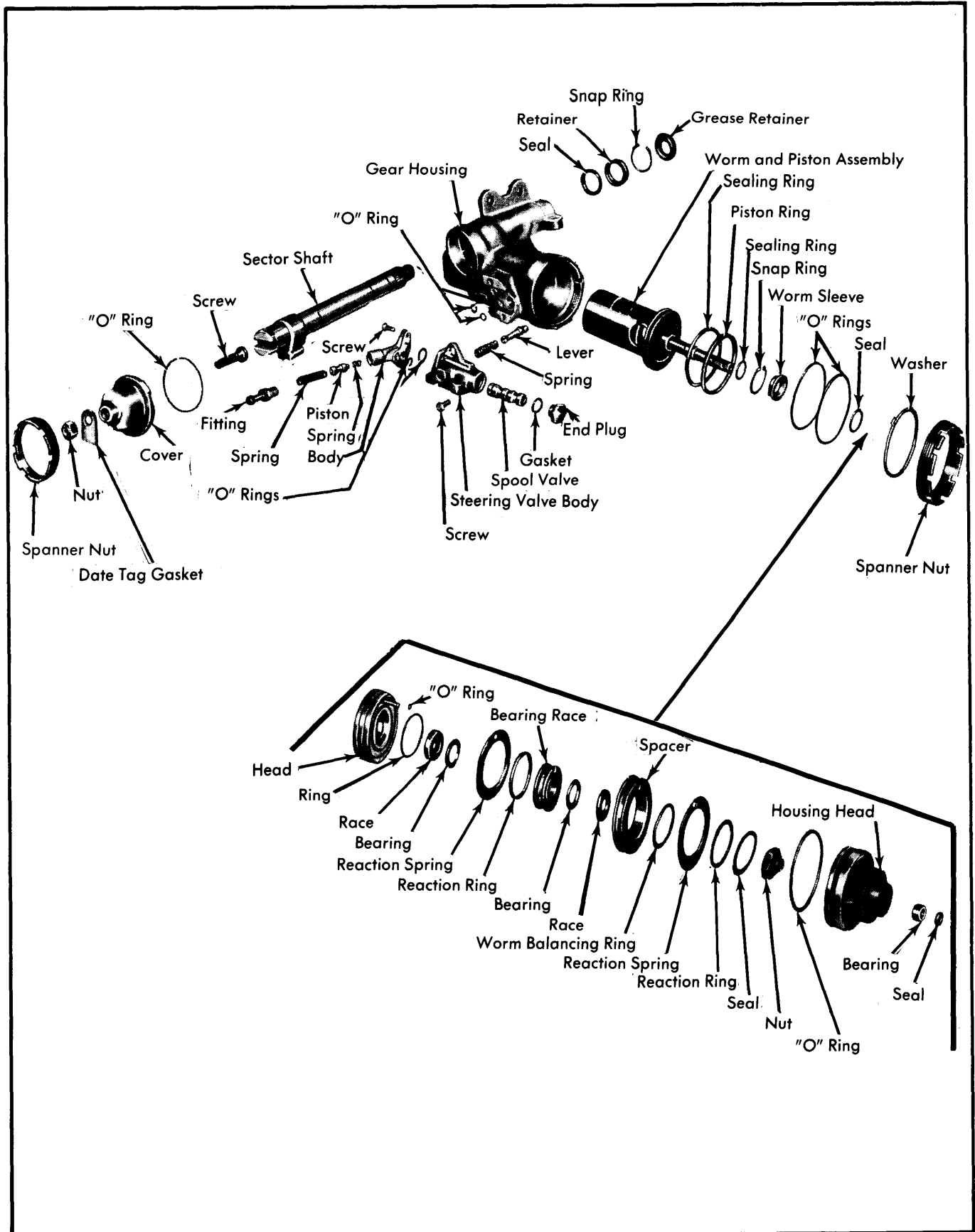

Fig. 5 Chrysler Corp. Power Steering Gear

CHRYSLER CORP. (Cont.)

hole in center bearing race and spacer with valve lever hole in gear housing. Install valve lever (double bearing end first) into center race and spacer through hole in steering gear housing to engage center race and spacer. Slots in valve lever must be parallel to wormshaft. Tap on end of lever lightly with wooden handle of hammer or screwdriver to seat lower pivot point in center race. Center lever in hole in housing by turning housing head (tap on reinforcing rib with hammer and drift).

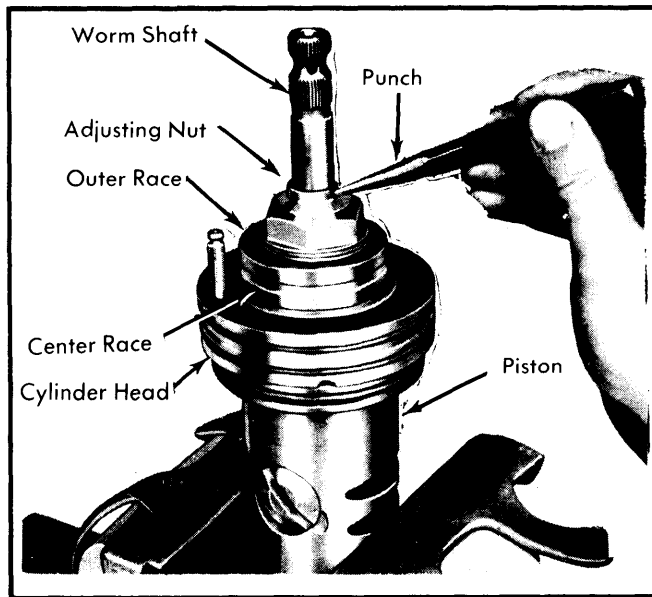

Fig. 6 Staking Adjusting Nut

13) Install housing head tang washer (available service part) to index with groove in housing. Install spanner nut and tighten. Valve lever must remain centered in hole in housing. Turn wormshaft until piston bottoms in both directions and note action of lever. Valve lever must be in center of hole and snap back to its center position when worm torque is relieved. Install valve lever spring (small end first). Set power piston at center of travel, install gear shaft and cover assembly with sector teeth indexed with piston rack teeth. Make sure that cover "O" ring is installed correctly and tighten cover spanner nut.

14) Install valve body on housing making sure valve pivot lever enters hole in valve spool. Be sure "O" ring seals are in place. Tighten valve mounting screws.

15) If new worm shaft and piston assembly has been installed, master serration on power steering gear worm shaft spline must be machined to properly center steering shaft coupling. To file master serration, power steering gear must be assembled and worm shaft centered in its travel. With steering gear in its normal upright position remove one tooth of the spline at the 12 o'clock position, using a file.

SECTOR SHAFT OIL SEAL

1) Sector shaft oil seal may be replaced without removing steering gear from vehicle. Remove steering arm nut. Disconnect steering gear arm from sector shaft with tool C-4150 or equivalent or damage to "T" slot ears on sector shaft

will result. Slide a threaded adapter (SP-3056 of tool C-3350) over end of sector shaft and threaded tool nut on sector shaft. Maintain pressure on threaded adapter with tool nut while screwing adapter far enough to engage metal portion of grease retainer. Place the two half rings (SP-1932), and tool retainer ring over both portions of the tool. Turn tool nut counterclockwise to remove retainer. Remove oil seal snap ring and seal back-up washer. Remove inner seal in same manner and using same tools as for grease retainer.

2) An acceptable alternate method of removing sector shaft oil seal, after disconnecting steering arm, is as follows: Carefully pry grease seal out of housing, then remove oil seal retaining snap ring and seal retainer. Place receptacle under gear and start engine. Turn steering wheel all the way to full left turn. Oil pressure will force seal out of housing.

3) Place new seal on flat surface (lip down), lubricate inner diameter with power steering fluid and insert seal protector sleeve (SP-1601). Position seal on sector shaft (seal lip in). Place tool adapter (SP-5148) with long step against new seal, slide it over shaft with seal lip toward housing. Install tool nut on sector shaft and tighten until shoulder of adapter contacts gear housing. Remove tool nut and adapter.

4) Install seal retainer and oil seal snap ring (identification stamp to outside). Fill housing cavity with multi-purpose grease and position grease retainer in housing bore. Place tool adapter (SP-5148) with short step of lip against retainer. Install tool nut on sector shaft and tighten tool nut until shoulder contacts gear housing. With steering gear and wheels in straight ahead position, install steering gear arm and nut.

WORM SHAFT OIL SEAL

Worm shaft oil seal may be replaced without removing steering gear from vehicle. Remove steering column, then remove oil seal using suitable tool (C-3638). Drive new oil seal in place (lip of seal toward housing), install and align steering column.

TIGHTENING SPECIFICATIONS

Application	Ft. Lbs.
Gear Housing-to-Frame Bolts	100
Sector Shaft Adjusting Screw Lock Nut	28
Sector Shaft Cover Nut	150
High Pressure Hose Fitting	
Pump End Fitting*	30
Gear Eng Fitting	19
Steering Arm Nut	175
Housing Head Spanner Nut	200
Valve Body Attaching Bolts	8
Valve Body End Plug	50
Control Valve Body Fitting	20
Steering Wheel Nut	60