

SAGINAW BALL BEARING WORM & NUT

American Motors
General Motors

DESCRIPTION

Saginaw manual steering gear is of the recirculating ball worm and nut type with steering shaft, worm shaft and ball nut all in line. The ball nut, mounted on worm, is driven by ball bearings which circulate in spiral grooves in both worm and ball nut as a rolling thread. Ball return guides, attached to nut, serve to recirculate both sets of balls. The ball nut is one piece and geared to sector shaft. Teeth on ball nut and sector are designed so a tighter fit exists between teeth when wheels are straight ahead. Worm shaft bearing adjuster is used to provide proper bearing preload on worm shaft. Sector gear lash is set by adjusting screw on end of sector shaft.

ADJUSTMENT

NOTE — Before any adjustments are made to gear, check for binding at frame bracket mounting bolts, instrument panel bracket, or flexible coupling. Steering shaft should run through full range in both directions without binding. Binding indicates misaligned steering gear on mountings or coupling. Always set worm bearing preload before setting sector shaft over-center adjustment.

WORM BEARING PRELOAD

1) If steering gear is on vehicle, remove horn ring or button and disconnect pitman arm from sector shaft using a suitable puller. Turn steering wheel gently $\frac{1}{2}$ turn from either stop, then

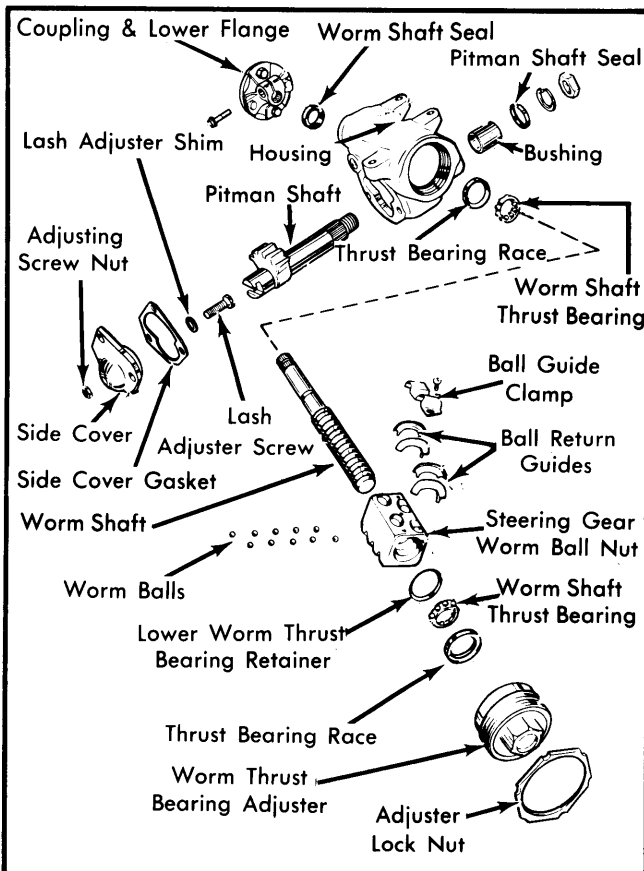

Fig. 1 Saginaw Ball Bearing Worm and Nut Steering Gear

loosen sector shaft adjusting screw several turns to eliminate sector load.

CAUTION — DO NOT turn steering wheel hard against stops with pitman arm removed from gear as damage to ball return guides could result.

2) Use a torque wrench having a 50 INCH Lb. maximum scale or less to measure preload. Attach torque wrench to steering wheel nut and turn through a 90° arc observing torque reading. If less than 5-8 INCH Lbs., loosen adjuster lock nut and turn worm thrust bearing adjuster to increase preload. Tighten adjuster lock nut and recheck preload.

SECTOR SHAFT OVER-CENTER ADJUSTMENT

Rotate steering wheel gently from stop-to-stop counting total number of turns. Turn wheel back half way to center sector on high spot. Rotate steering wheel $\frac{1}{2}$ turn either side of center. Use a 50 INCH Lb. torque wrench or less on steering wheel nut and note torque while turning wheel over sector high spot. If not within 4-10 INCH Lbs. more than worm bearing preload, loosen adjusting screw lock nut and turn screw until correct over-center torque is obtained. After adjustments are completed, install steering arm and tighten nuts.

NOTE — Total worm and sector preload must not exceed 16 INCH Lbs.

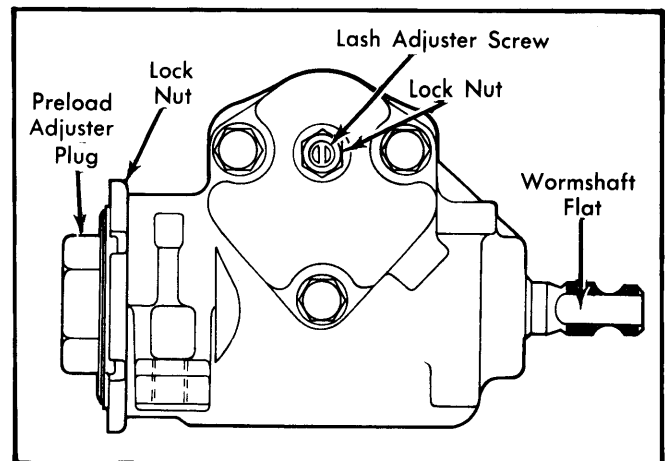

Fig. 2 Adjustment Locations

REMOVAL & INSTALLATION

NOTE — Observe the following recommended procedures applying to specific makes and models of vehicles before servicing steering gears.

American Motors — Flexible coupling has a pointer which must align with flat of shaft when installing. Loosen steering column mounting bolts and move column in or out if necessary to straighten flexible coupling. See *Collapsible Steering Columns* in this Section.

General Motors (Flexible Coupling) — Install flexible coupling onto the steering gear wormshaft splined end. Align the flat in the coupling with the flat on the shaft. Install coupling clamp bolt and torque to specifications. Install intermediate

SAGINAW BALL BEARING WORM & NUT (Cont.)

shaft to flexible coupling and loosely install flange bolts. Align flexible coupling pins in center of intermediate shaft flange slots and torque flange-to-coupling bolts to specifications. Install coupling shield.

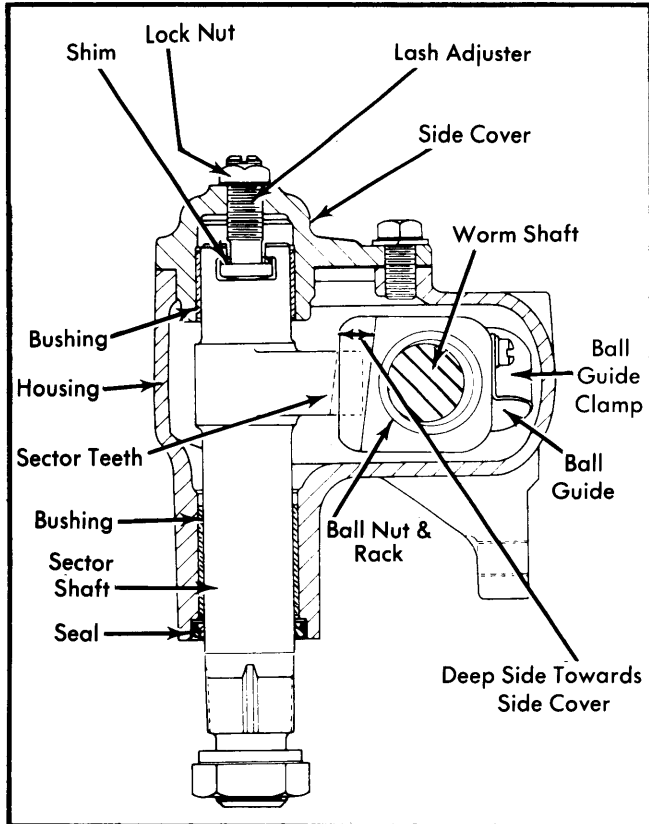

Fig. 3 Steering Gear - Sectional View

STEERING GEAR

Removal - 1) Turn steering wheel so front wheels are pointing straight ahead. Disconnect battery ground cable. Remove steering gear coupling shield (if equipped) and disconnect steering shaft coupler bolt. Mark alignment of worm shaft to steering shaft for reassembly reference.

2) Raise vehicle and mark position of sector shaft to pitman arm if not master splined. Remove pitman arm nut and remove arm with suitable puller. Remove steering gear mounting bolts and remove gear from vehicle.

CAUTION - DO NOT hammer on end of puller to remove pitman arm.

Installation - 1) Align all components before tightening any bolts. Align worm shaft flat or mark to match coupling and install gear with mounting bolts finger tight. Tighten coupling pinch bolt, align gear to coupling and tighten gear mounting bolts.

2) Install pitman arm on sector shaft master spline or as previously marked. Tighten pitman arm nut and connect battery ground cable. Install coupling shield (if equipped). Check steering movement for smooth operation before lowering vehicle and adjust if required. See *Collapsible Steering Columns* in this section for column adjustment.

SECTOR SHAFT SEAL

Removal - Seal can be replaced without removing steering gear on most vehicles. Remove pitman arm using suitable puller. Pry sector shaft seal from housing with screwdriver, using care not to scratch housing bore.

Installation - Lubricate new seal with suitable steering gear lubricant and cover splines with shim stock or card stock to protect seal lips. Position seal in sector shaft bore and tap into place using a suitable socket. Remove protective stock and replace pitman arm.

OVERHAUL

NOTE - Clean entire outside surface of steering gear before disassembly to avoid contaminating worm shaft and ball nut assembly.

DISASSEMBLY

1) Mount gear in suitable holding fixture or clamp gear mounting lug in vise. Turn worm shaft until sector gear is centered on ball nut (straight ahead position). Remove side cover bolts and tap lightly on end of sector shaft to remove. Remove sector shaft and side cover as an assembly. Separate shaft from cover by turning adjusting screw clockwise. Remove adjusting screw from sector shaft slot using care not to lose shim.

2) Scribe a locating mark on flexible coupling and worm shaft, then remove coupling from shaft. Loosen worm shaft adjuster lock nut with spanner wrench or a punch. Remove worm bearing adjuster, wormshaft and ball nut. Pry lower bearing out of adjuster nut with screwdriver. Turn housing on end to remove upper bearing.

CAUTION - DO NOT allow ball nut to run down to either end of worm as damage may result to ball guides. Worm shaft should be horizontal when removing adjuster nut and worm shaft assembly.

3) Do not disassemble ball nut unless there is an indication of binding, tightness or wear on worm shaft. If required, remove ball guide clamps and turn ball nut over a clean pan to catch balls. Rotate worm shaft slowly from side-to-side to remove all balls and remove worm shaft.

CLEANING & INSPECTION

Wash all parts with clean solvent and blow dry with air. Inspect worm and nut grooves for scoring or pitting. Examine all bearings, bearing cups, shaft surfaces, bushings and oil seals for wear or damage. Replace components as required.

COMPONENT SERVICE

Sector Shaft & Worm Shaft Seals - Pry out seals using a screwdriver if not previously removed. Before installing new seals, check condition of sector shaft bushings and upper worm shaft bearing race. Use a suitable size socket pressing on outer seal diameter to install seals.

Sector Shaft Bushings or Bearings - Support gear housing in an arbor press and use suitable tool to press out bushings. Use same tool (C-3875) with adapter to install new bushings or bearings. Worn or defective side cover bushings will require replacement of the entire side cover assembly.

SAGINAW BALL BEARING WORM & NUT (Cont.)

Worm Shaft Bearing Cups — Remove bearing cup from adjuster plug using suitable puller and slide hammer. Remove bearing cup from housing with a punch. To install bearing cups, press in new cups with a bench press.

REASSEMBLY

1) Lubricate all components before reassembly. Place ball nut on workbench with ball guide holes facing upward and deep side of ball nut teeth toward front edge of workbench. Insert worm shaft into nut so that equal number of shaft threads are visible at each end of nut. Place one ball bearing in each guide hole, then move worm shaft in nut so that ball bearings roll into nut threads and support worm shaft.

2) Assemble ball guides and place in ball nut. Place equal number of remaining balls into each circuit through holes in ball guides. To ease installation, rotate shaft slightly while inserting ball bearings. Install ball guide clamp and tighten screws. Lubricate wormshaft threads and rotate in and out of ball nut to circulate lubricant.

3) Install worm shaft bearings in housing and adjuster plug. Install adjuster plug bearing retainer. Lubricate threads of adjuster plug before assembly and wrap tape around worm shaft splines to protect seal during installation. Install worm and nut assembly in housing and tighten adjuster plug hand tight. On

American Motors models, pack steering gear housing with chassis grease.

4) Check sector shaft adjusting screw end play. Screw must turn freely and have a maximum of .002" end play. Turn worm shaft so ball nut is at center of travel and insert sector shaft. Tape sector shaft splines prior to installation to protect seal. Pack remaining portion of gear with chassis lube (American Motors models) or fill housing with steering gear lubricant meeting GM specification GM4673M (or equivalent).

5) Install new gasket and side cover on housing by turning adjusting screw into cover counterclockwise. Tighten cover bolts finger tight, then tighten adjuster screw until it bottoms and back off 1/2 turn. Tighten side cover bolts to 30 ft. lbs. Adjust worm bearing preload and sector shaft as previously described.

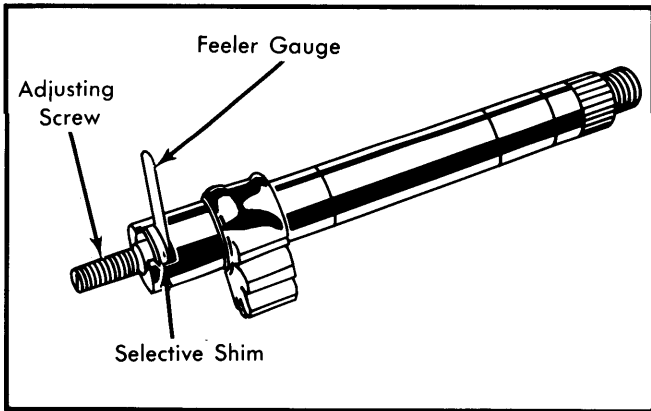

Fig. 4 Checking Sector Shaft End Clearance

TIGHTENING SPECIFICATIONS

Application	Ft. Lbs.
Gear-to-Frame Bolts	①70
Pitman Shaft Nut	
American Motors	②85
General Motors	185
Side Cover Bolts	30
Pitman Adjusting Screw Locknut	25
Worm Bearing Adjuster Locknut	
American Motors	50
General Motors	85
Steering Wheel Nut	
American Motors	25
General Motors	30
Flexible Coupling Nuts	20
Flexible Coupling Pinch Bolt	30

① — 30 ft. lbs. for Corvette only.

② — Stake nut to shaft threads in at least one place.