

Rear Suspension

ELDORADO, RIVIERA, SEVILLE & TORONADO

DESCRIPTION

Rear suspension is independent type, with trailing control arms, coil springs, air adjustable shock absorbers and a stabilizer bar. The hub and wheel bearing are a one-piece, no-maintenance assembly bolted to the control arm.

ADJUSTMENT

RIDING HEIGHT

See *Riding Height Adjustments and Specifications* in **WHEEL ALIGNMENT** Section.

WHEEL ALIGNMENT

See *Camber and Toe-In Adjustments and Specifications* in **WHEEL ALIGNMENT** Section.

REMOVAL & INSTALLATION

SHOCK ABSORBER

Raise vehicle and support control arm. Disconnect air line to rear shock by twisting spring clip 90° and pulling carefully on air line and connector. Remove upper and lower shock absorber mounting bolts and remove shock absorber. Reverse removal procedure to complete assembly. Add air to shock absorber.

COIL SPRING

Removal — Raise vehicle so rear wheels are off floor. Support bottom of control arm with jack and disconnect air line at shock absorber. If working on left side, remove ELC link at control arm. Remove upper shock absorber mounting bolt and lower control arm slowly. Remove spring.

Installation — Position spring with upper and lower insulators. Raise control arm, install shock bolt and connect ELC link and air line. Add air to ELC system and torque all bolts to specifications.

NOTE — Shock absorber should be fully extended when air line is connected to avoid damage to boot.

REAR CONTROL ARM

Removal — Raise and support vehicle. Remove tire and wheel assembly, stabilizer bar, brake line bracket and brake caliper. Mark hub and rotor for reassembly and remove rotor. If working on left side, remove ELC link at control arm. Support control arm with jack, remove ELC line to shock and remove shock absorber. Lower control arm, remove coil spring with insulators and remove control arm mounting bolts.

Installation — Reverse removal procedure noting the following: Shock absorber should be fully extended when air line is connected to avoid damage. Lightly pressurize system by

adding air at compressor service valve in engine compartment. Check rear wheel alignment.

STABILIZER BAR

Raise and support vehicle. Remove nut, bolt and washers holding stabilizer to control arm. Remove inside bolt of stabilizer link, loosen outer bolt, and rotate link out of way. Remove stabilizer bar. Reverse procedure to install.

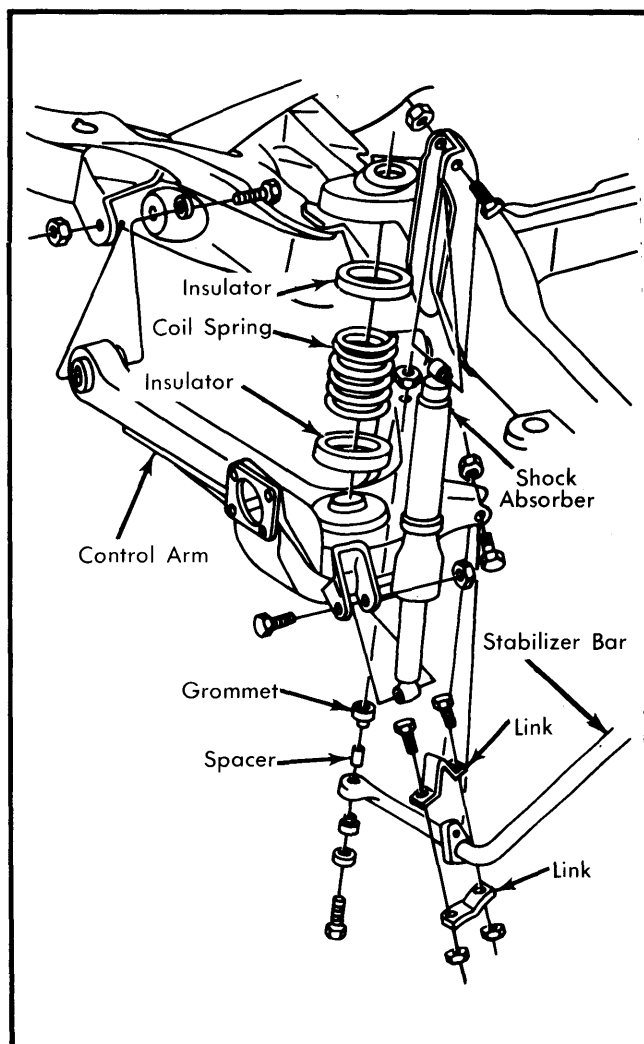

Fig. 1 Eldorado, Riviera, Seville and Toronado Rear Suspension

TIGHTENING SPECIFICATIONS

Application	Ft. Lbs.
Control Arm Pivot Bolts	100
Stabilizer Link Bolts	22
Stabilizer-to-Control Arm Bolts	60-65
Upper Shock Mount	65
Lower Shock Mount	65