

Rear Suspension

FORD MOTOR CO. ESCORT & LYNX

Escort
Lynx

DESCRIPTION

These vehicles use a modified MacPherson strut independent rear suspension. Each side consists of a shock strut, lower control arm, tie rod, forged spindle and a coil spring mounted between the lower control arm and the body side rail. The shock strut assembly is attached to the body side panel by a rubber insulated top mount assembly and nut. The lower end is bolted to the spindle. The lower control arm attaches to the underbody and the spindle. The tie rod attaches to the underbody and the spindle.

ADJUSTMENT

RIDING HEIGHT

See *Riding Height Adjustment and Specifications* in **WHEEL ALIGNMENT** Section.

REMOVAL & INSTALLATION

COIL SPRING

NOTE — If a twin post hoist is used, vehicle must be supported with jack stands placed under jack pads of underbody, forward of tie rod bracket.

Removal — Raise vehicle on hoist and place floor jack under lower control arm. Raise lower control arm to curb height. Remove tire and wheel. Remove nut, bolt and washer retaining lower control arm to spindle. Slowly lower control arm with floor jack until spring can be removed.

Installation — 1) Using new spring insulator, index insulator against tip of spring and press down until it snaps into place. Install spring in control arm, making sure it is properly seated in spring pocket. See Fig. 2.

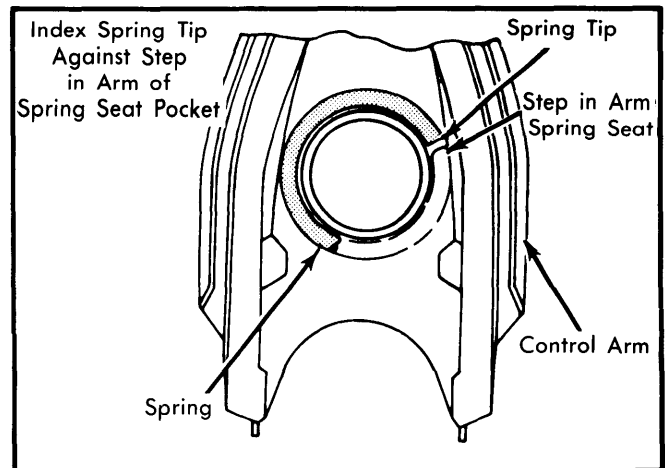

Fig. 2 Index Location for Rear Spring

2) Raise spring and control arm with floor jack. Position spring in pocket on underbody. Using new bolt, nut and washer, attach control arm to spindle. Bolt head should face front of vehicle.

3) Tighten bolt to specifications. Install tire and wheel. Remove floor jack and lower vehicle.

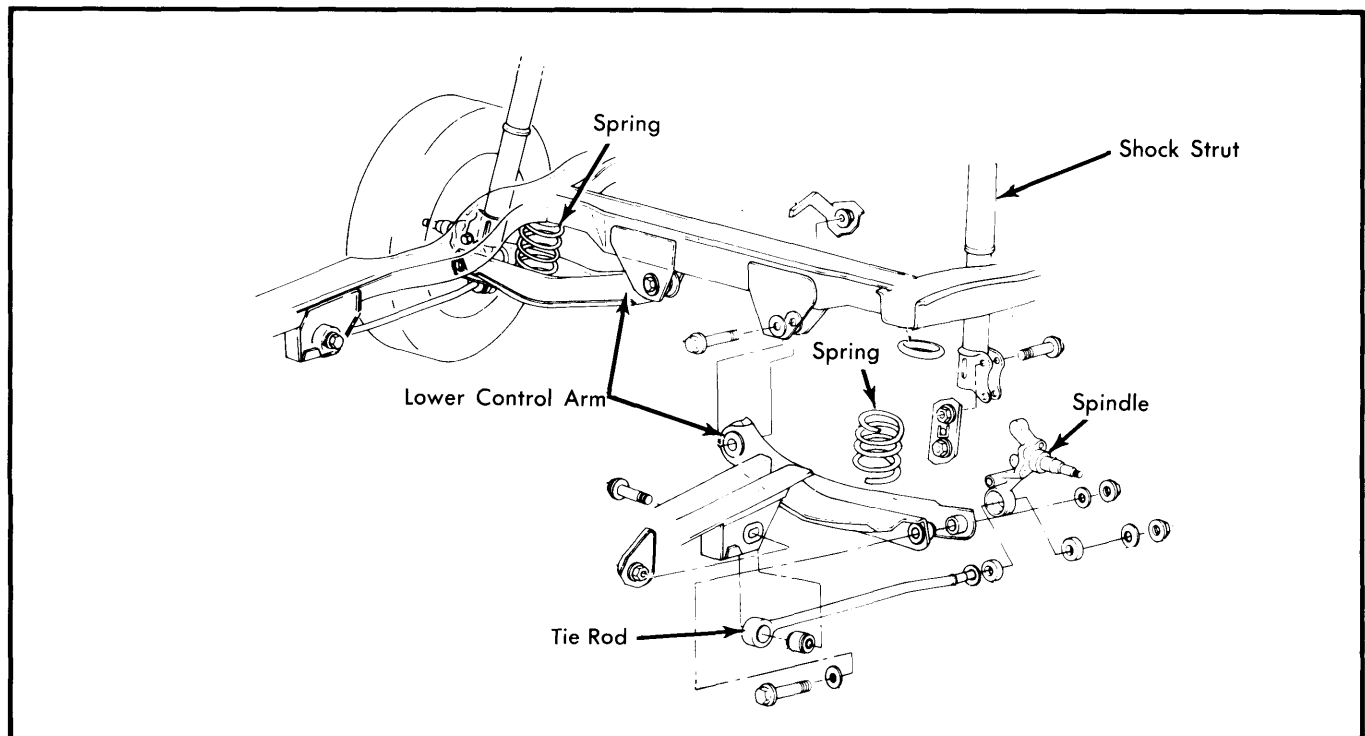

Fig. 1 Rear Suspension Assembly, Escort and Lynx

FORD MOTOR CO. ESCORT & LYNX (Cont.)

LOWER CONTROL ARM

NOTE — If a twin post hoist is used, floor jacks must be placed under lifting pads on underbody forward of tie rod body bracket. Lower rear hoist post out of way.

Removal — 1) Raise vehicle on hoist. Remove tire and wheel. Place floor jack under lower control arm between spring and spindle end mounting.

NOTE — Rear suspension should be at full rebound and shock strut fully extended.

2) Remove nuts from control arm-to-body mounting and control arm-to-spindle mounting. Do not remove bolts at this time. Remove spindle end mounting bolt.

3) Slowly lower floor jack until spring and insulator can be removed. Remove bolt from body end and remove control arm.

Installation — 1) Using new bolt and nut, attach lower control arm to body bracket. **DO NOT** tighten. Place spring in spring pocket in lower control arm.

NOTE — Make sure spring pigtail is properly indexed in control arm, and that insulator is seated and indexed at top of spring.

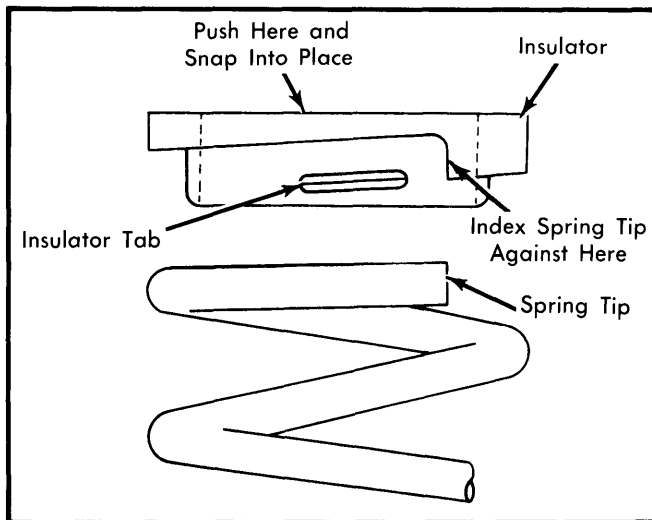

Fig. 3 Positioning Coil Spring in Insulator

2) Using floor jack, raise lower arm until it comes in line with mounting hole in spindle. Using new bolt, nut and washer, attach lower arm to spindle. **DO NOT** tighten.

3) Using floor jack, raise lower arm to curb height. Tighten all bolts. Install tire and wheel. Remove jacks and lower vehicle.

TIE ROD

Removal — 1) Raise vehicle on hoist. Scribe a vertical mark on tie rod front bracket at bolt head centerline, for proper installation of new bolt.

2) Remove nut, washers and insulator attaching tie rod to spindle. Remove nut and bolt attaching tie rod to body bracket, and remove tie rod.

NOTE — It may be necessary to pry front bracket sheet metal apart slightly to remove tie rod.

Installation — 1) Place dished washer with larger inside diameter over end of tie rod with flange toward middle of rod. With new bushings installed on spindle, insert tie rod through bushings and place eye of rod into body bracket.

NOTE — Two new dished washers must be used for reinstallation. One has a larger inside diameter than the other and must be installed in correct location. See Fig. 4.

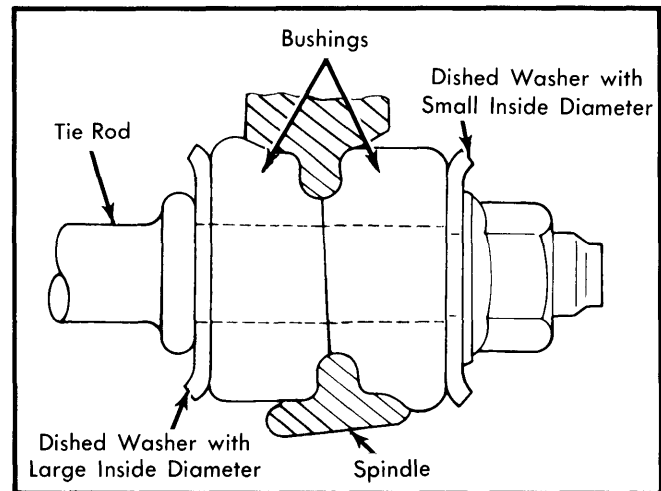

Fig. 4 Tie Rod-to-Spindle Installation

2) Using new bolt and nut, attach tie rod to body, but do not tighten. Place washer with smaller inside diameter over end of tie rod with flange toward end of rod. Install new nut and tighten.

3) Using floor jack, raise lower control arm to curb height. Line up center of bolt head with scribe mark made previously and tighten front bolt. Remove jack and lower vehicle.

TIE ROD BUSHINGS

Removal — Remove tie rod as previously outlined. Working from beveled side of tie rod, use remover tool (T81P-5896A), and clamp tool (T74P-3044-A1), and remove bushing from tie rod.

Installation — To install, reverse removal procedure.

SPINDLE

Removal — 1) Raise vehicle on hoist. Lower control arm must be raised to curb height. Remove wheel, tire, brake drum and wheel bearings. Remove brake backing plate from spindle.

2) Remove tie rod retaining nut and washer. Remove nuts and bolts retaining strut to spindle. Remove nut and bolt retaining lower control arm to spindle and remove spindle.

NOTE — Bushings in spindle can be popped out with a screwdriver, and replaced by pushing in by hand.

Rear Suspension

FORD MOTOR CO. ESCORT & LYNX (Cont.)

Installation — 1) With new tie rod bushings in place and disched washer installed on tie rod, position spindle over tie rod end. Attach spindle to shock strut with bolt heads toward rear of vehicle.

2) Attach lower control arm to spindle using new bolts and nuts. Install tie rod to spindle and tighten. Install brake backing plate to spindle. Install brake drum, bearings and wheel assembly.

SHOCK ABSORBER STRUTS

Removal — 1) Remove rear compartment access panels on 2-door models, or quarter trim panels on 4-door models. Loosen, but do not remove, top shock absorber attaching nut with a 43 mm deep socket and external hex tool (D81P-18045-A3), while holding strut rod with a 6 mm Allen wrench.

2) Raise vehicle on hoist and remove tire and wheel. Remove clip retaining flexible brake hose to rear shock and move hose aside.

NOTE — If a frame contact hoist is used, support lower control arm with floor jack. If twin post hoist is used, support body with floor jacks placed on lifting pads forward of tie rod body bracket.

3) Loosen nuts and bolts retaining shock to spindle, but do not remove. Remove top mounting nut, washer and rubber insulator. Remove 2 bottom mounting bolts and remove shock.

Installation — 1) Extend shock absorber to maximum length. Install new lower washer and insulator assembly. Use tire lubricant to ease insertion into quarter panel shock tower.

2) Position upper part of shock shaft into shock tower opening in body and push slowly on lower part of shock until mounting holes are lined up with mounting holes in spindle.

3) Install, but do not tighten, new lower mounting bolts and nuts, with bolt heads facing to rear. Place new washer and upper insulator on upper shock shaft.

4) Using a 43 mm deep socket and external hex tool (D81P-18045-A3), while holding strut shaft with 6 mm Allen wrench, tighten upper shock nut. Tighten lower mounting bolts.

5) Install brake flex hose and retaining clip. Install wheel and tire assembly. Remove floor jacks and lower vehicle. Install quarter trim panels or rear access panels.

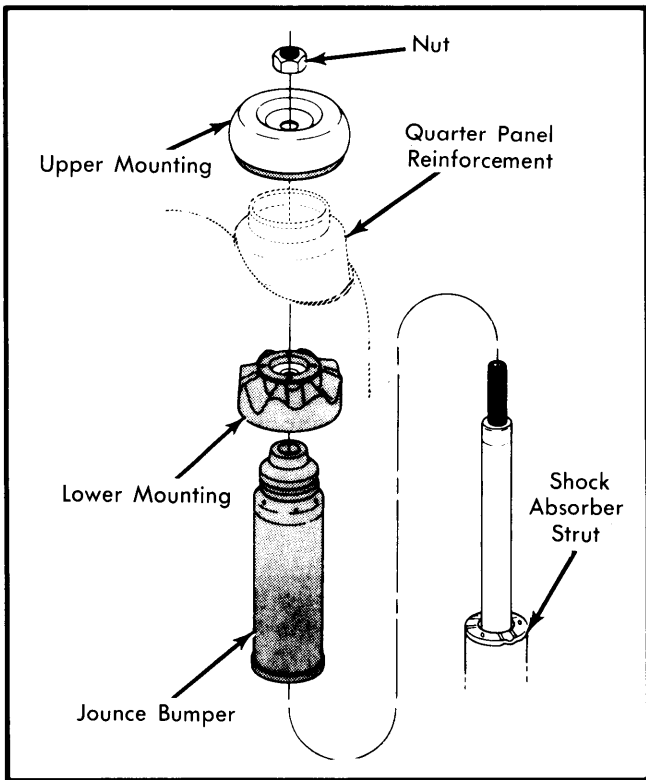

Fig. 5 Top Shock Mounting Components

TIGHTENING SPECIFICATIONS

Application	Ft. Lbs.
Shock Absorber-to-Body	60-70
Shock Absorber-to-Spindle	90-100
Control Arm-to-Body	65-75
Control Arm-to-Spindle	90-100
Tie Rod-to-Body	90-100
Tie Rod-to-Spindle	65-75