

ELDORADO, RIVIERA, SEVILLE & TORONADO

Buick Riviera
 Cadillac Eldorado
 Cadillac Seville
 Oldsmobile Toronado

DESCRIPTION

Front suspension is torsion bar with control arms, stabilizer bar and shock absorbers. Front end of each torsion bar is attached to lower control arm. Rear of each torsion bar is mounted at torsion bar crossmember with an adjustable arm for car height adjustment. Steering knuckle is suspended by conventional ball joints. Front wheel bearings do not require adjustment.

ADJUSTMENT

CASTER & CAMBER

See *Caster and Camber Adjustments and Specifications in WHEEL ALIGNMENT Section.*

RIDING HEIGHT

See *Riding Height Adjustments and Specifications in WHEEL ALIGNMENT Section.*

BALL JOINT CHECKING

See *Ball Joint Checking in WHEEL ALIGNMENT Section.*

REMOVAL & INSTALLATION

FRONT HUB & BEARING ASSEMBLY

Removal — Remove wheel cover, cotter pin and retainer, then loosen axle nut. Siphon $\frac{2}{3}$ of fluid from master cylinder reservoir then lift car and support with safety stands. Remove tire and wheel assembly, then compress caliper piston by prying between ball joint stud and caliper. Remove locating bolts and wire caliper out of way. Remove disc, axle nut and washer. Remove 3 hub retaining bolts on inside of steering knuckle and remove hub assembly carefully. Support drive axle to avoid damage to joints and seals.

Installation — Reverse removal procedure to complete assembly. Refill master cylinder and bleed system if necessary.

STABILIZER BAR

Removal — Raise car and support with safety stands. Remove bolts from bottom of both links, then grommets and retainers. Unbolt stabilizer bushing brackets from frame and remove bar.

Installation — Reverse removal procedure and note the following: Torque bolts to specifications. After tightening, link bolt must be cut off $\frac{1}{4}$ " below nut.

STEERING KNUCKLE & SEAL

Removal — 1) Loosen axle nut, drain $\frac{2}{3}$ of master cylinder fluid, then raise and support vehicle. Remove wheel and tire assembly, disc brake caliper, and drive axle nut. Using suitable puller, remove tie rod end from steering knuckle.

2) Disconnect lower ball joint using suitable tool. Remove upper ball joint by prying between knuckle and control arm while striking knuckle sharply with brass drift and hammer. Support drive axle to prevent damage to joints and seals and remove knuckle. Pry seal out of groove in knuckle.

Installation — To install, reverse removal procedures while noting following: Lubricate seal and install in knuckle using suitable tool (J-28574). Cotter pin on upper ball joint must be bent up and flat, to prevent interference with or damage to constant velocity joint seal.

UPPER BALL JOINT

Removal — Raise and support vehicle. Remove wheel and tire assembly. Disconnect upper ball joint by prying between upper control arm and steering knuckle. Using hammer and brass drift, strike knuckle sharply to help loosen ball joint stud. Drill out rivets and remove ball joint.

Installation — Install ball joint with bolts inserted from under side of control arm. Reverse removal procedure and tighten all bolts to specifications.

LOWER BALL JOINT

Removal — Raise and support vehicle. Remove steering knuckle as previously described. Drill out rivets and remove ball joint.

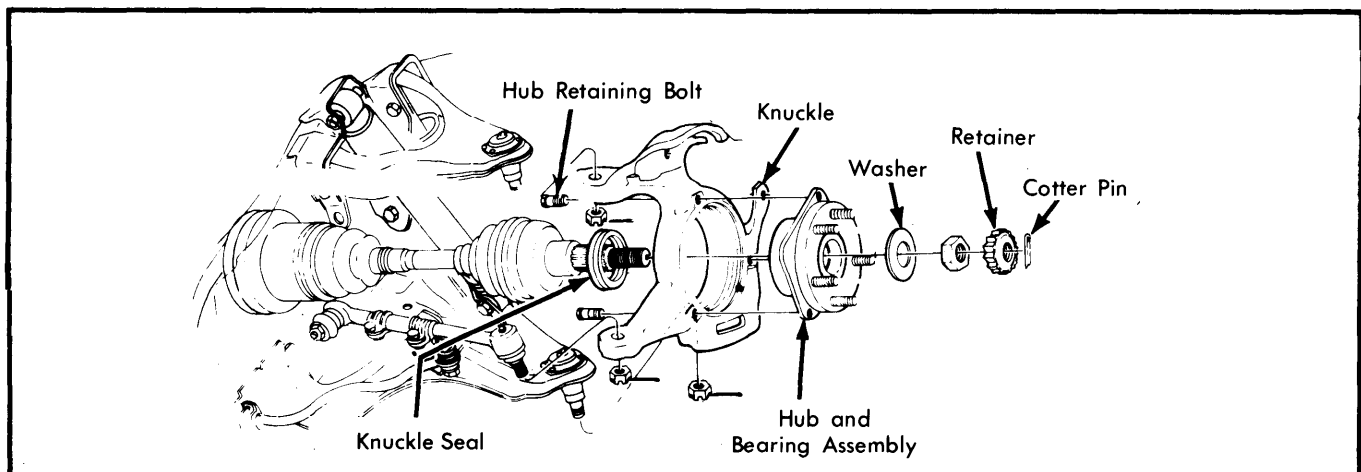

Fig. 1 Steering Knuckle Removal

Front Suspension

ELDORADO, RIVIERA, SEVILLE & TORONADO (Cont.)

Installation — Install ball joint with bolts inserted from under side of control arm. Reverse removal procedure and tighten all bolts to specifications. Check alignment and riding height.

TORSION BAR

Removal — Raise and support vehicle. Position suitable tool (J-22517-02 or BT-6601) as shown in illustration. Tighten center bolt until adjusting bolt and nut can be removed from crossmember. Release tension on torsion bar, slide forward in lower control arm until rear end of torsion bar clears crossmember. Pull end of bar down and back to remove from control arm.

Installation — Lubricate 3" of each end of torsion bar with extreme pressure chassis lubricant, then install torsion bar by reversing removal procedures and tighten nuts and bolts. Check riding height and wheel alignment.

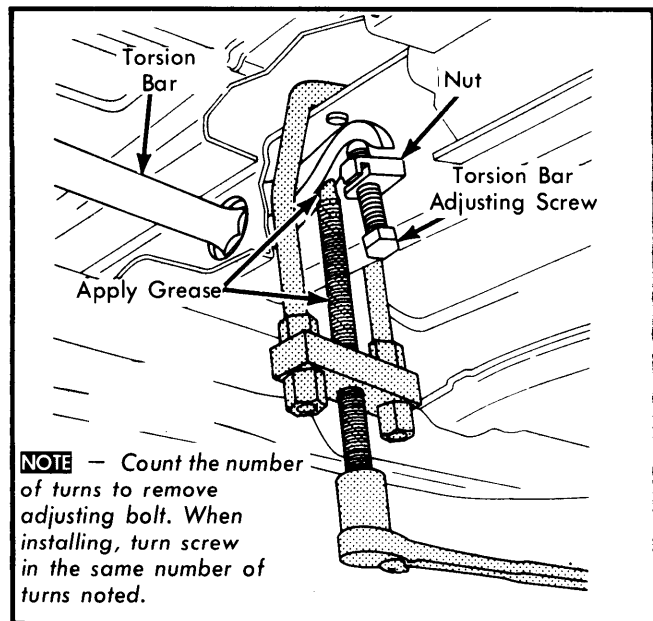

Fig. 2 Torsion Bar Removal

UPPER CONTROL ARM

Removal — Raise vehicle and support under lower control arm. Remove wheel and tire assembly and upper shock attaching bolt. Remove cotter pin and nut on upper ball joint. Disconnect brake hose clip. Unbolt and remove caliper assembly from disc, wire out of way and remove disc. Disengage upper ball joint from steering knuckle. Remove 2 control arm bolts and remove control arm by guiding shock absorber through access hole in arm.

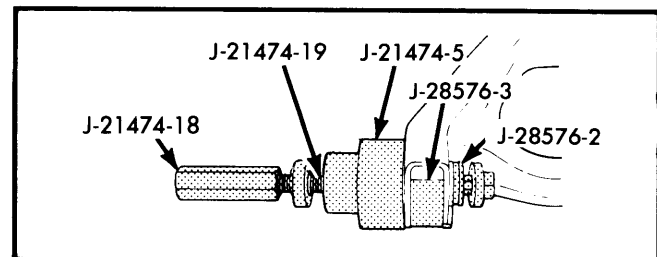

Fig. 3 Upper Control Arm Bushing Removal

Bushing Service — Remove upper control arm as previously described. Spray bushings with silicone lubricant to ease removal. Press out bushings, install new bushings and reverse removal procedures to complete assembly.

Installation — Reverse removal procedures, noting following: When installing bolts into cam assemblies, both bolt holes should be mounted downward. Cotter pin on upper ball joint must be bent upward to prevent damage to constant velocity joint seal. Check riding height and wheel alignment.

LOWER CONTROL ARM

Removal — Raise and support vehicle. Remove torsion bar and steering knuckle as previously described. Disconnect stabilizer link and lower mount of shock absorber. Ensure that drive axle is supported, then remove lower control arm pivot bolts and remove arm.

Bushing Service — With lower control arm removed from vehicle, spray bushings with silicone lubricant and install suitable tools as shown in Fig. 4. Press bushings out of lower control arm. Install new bushings and reverse removal procedure to complete assembly. Check riding height and wheel alignment.

Installation — Reverse removal procedures to complete installation. Check riding height and wheel alignment.

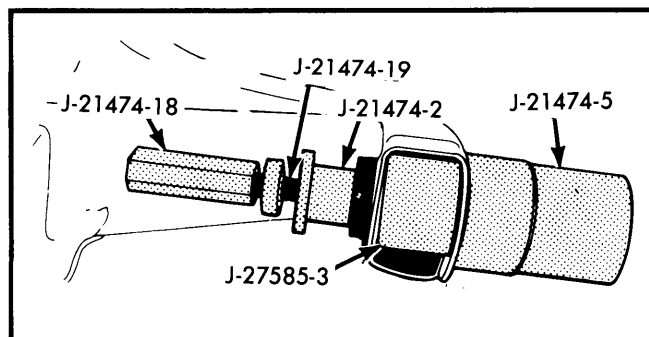

Fig. 4 Lower Control Arm Bushing Removal

TIGHTENING SPECIFICATIONS

Application	⊙Ft. Lbs.
Stabilizer Link Bolt	13
Stabilizer Bar Bracket-to-Frame	24
Upper Shock Absorber Mount	95
Lower Shock Absorber Mount	75
Upper Control Arm Pivot Bolt	70
Lower Control Pivot Bolt	90
Upper Ball Joint Stud Nut	90
Lower Ball Joint Stud Nut	65
Replacement Ball Joint Mount Bolts	8
Tie Rod End-to-Steering Knuckle	40
Wheel Bearing Assembly-to-Knuckle	75
Drive Axle Nut-to-Hub and Bearing	175

⊙ — When installing nut which requires cotter pin, turn nut in direction of tightening to align pin hole. DO NOT back off nut to align.