

# Front Suspension

## FORD MOTOR CO., ENCLOSED SPRING

Ford, Mercury,  
Lincoln Town Car, Mark VI

### DESCRIPTION

The front suspension is a ball joint type with a coil spring located between the upper and lower control arms. The upper control arm pivots on bushings located on a shaft assembly which is bolted to the frame. The lower arm pivots on a bolt attached to the number 2 crossmember. This suspension is similar to the spring tower suspension used on other models except for the location of the coil spring. On the spring tower models the spring is located above the upper control arm. See *Ford Motor Co., Spring Tower* in this Section.

### ADJUSTMENT

#### CASTER & CAMBER

See *Caster and Camber Adjustments and Specifications* in WHEEL ALIGNMENT Section.

#### RIDING HEIGHT

See *Riding Height Adjustments and Specifications* in WHEEL ALIGNMENT Section.

#### FRONT WHEEL BEARINGS

See *Wheel Bearing Adjustment* in WHEEL ALIGNMENT Section.

#### BALL JOINT CHECKING

See *Ball Joint Checking* in WHEEL ALIGNMENT Section.

### REMOVAL & INSTALLATION

#### BALL JOINTS

**NOTE** — Upper and lower control arms must always be replaced as an assembly. Do not install ball joints or other components in used control arm.

#### STABILIZER BAR BUSHING

**Removal** — Raise vehicle on hoist. Remove nut, washer and insulator from lower end of stabilizer bar attaching bolt. Remove bolt, remaining washers, insulators and spacer.

**Installation** — Assemble cup washer and new insulator on attaching bolt. Insert bolt through stabilizer bar, then install new washer and insulator. Install spacer, cup washer and insulator on bolt. Install bolt through lower arm and install new insulator and cup washer. Install and tighten bolts.

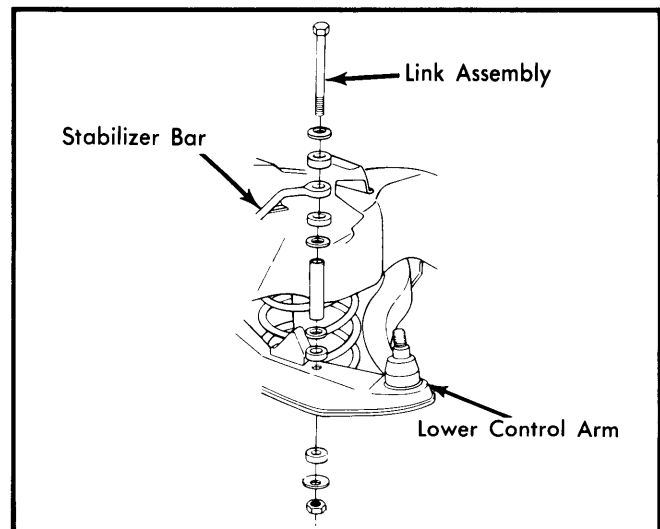

Fig. 1 Exploded View of Stabilizer Bar Bushings

#### STABILIZER BAR INSULATOR

**Removal & Installation** — Raise vehicle and support with safety stands. Disconnect stabilizer bar from each link, disconnect stabilizer attaching brackets and remove stabilizer. Cut insulators off bar. Using a suitable rubber lubricant, replace

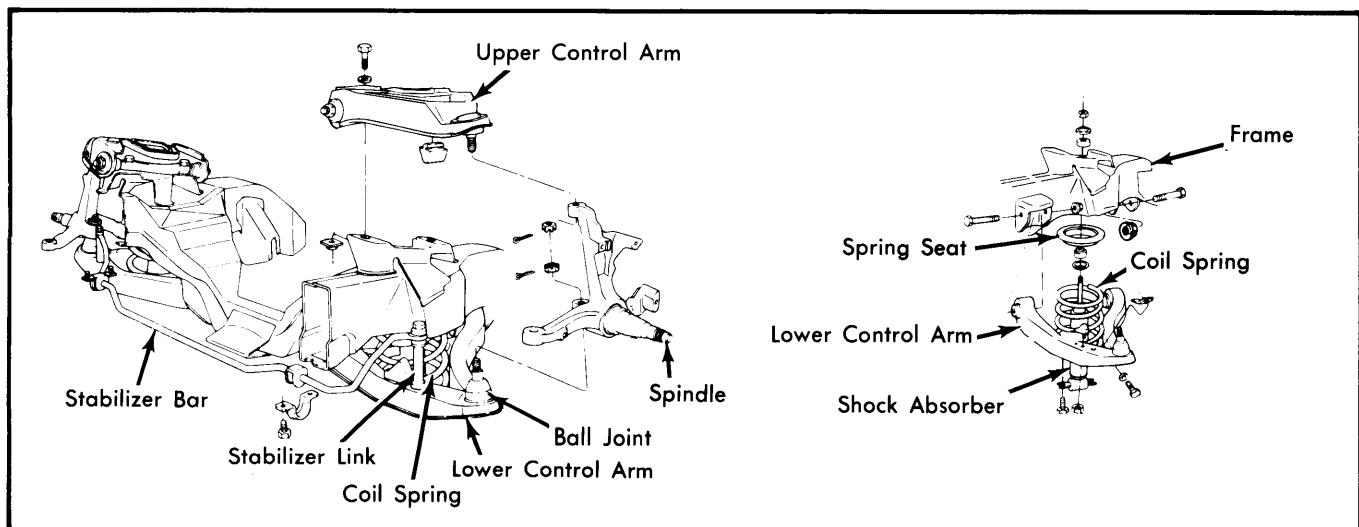

Fig. 2 Exploded Views of Ford Enclosed Spring Type Front Suspension

## FORD MOTOR CO., ENCLOSED SPRING (Cont.)

insulators on bar. To install, reverse removal procedure making sure that stabilizer link does not interfere with brake hoses.

**NOTE** — New stabilizer bar-to-lower control arm nuts and bolts should be installed each time bar is removed.

### COIL SPRING

**Removal** — 1) Raise vehicle on hoist. Remove tire and wheel. Disconnect stabilizer bar link from lower arm. Remove shock absorber-to-lower arm assembly attaching bolts.

2) Remove upper nut, retainer and grommet from shock absorber and remove shock absorber. Remove steering center link from pitman arm. Support vehicle with safety stands under jacking pads and lower hoist for working room.

3) Using spring compressor tool (D-78P-5310-A), install one plate with pivot ball seat facing downward into coils of spring. Rotate plate so it is flush with upper surface of lower arm.

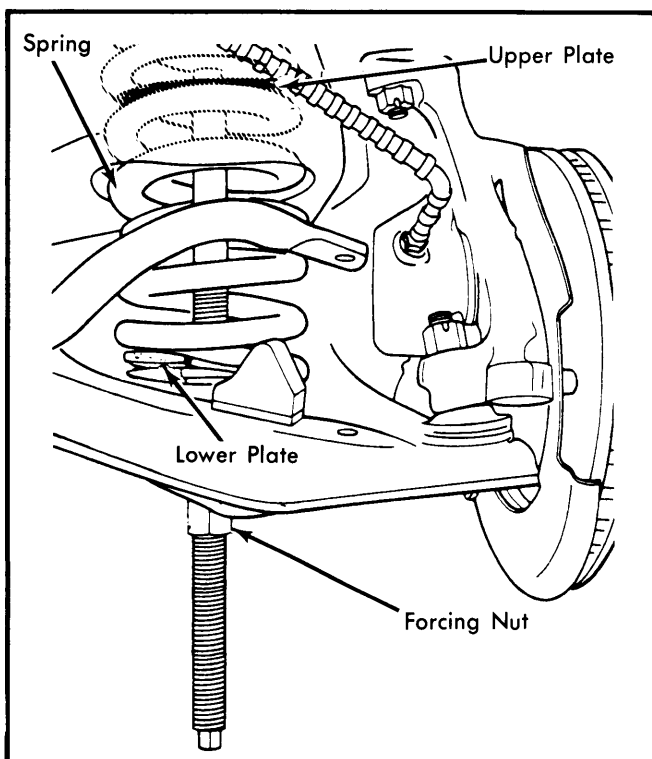

**Fig. 3 Compressor Tool in Position for Removal**

4) Install other plate with pivot ball seat facing up into coils of spring. Insert upper ball nut through coils of spring so nut rests in upper plate.

5) Insert compression rod into opening in lower arm through upper and lower plate and upper ball nut. Insert securing pin through upper ball nut and compression rod.

**NOTE** — Pin can only be inserted one way into upper ball nut because of a stepped hole design.

6) With ball nut secured, turn upper plate so it walks up coil and contacts upper spring seat. Back off  $\frac{1}{2}$  turn. Install lower

ball nut and thrust washer on compression rod and screw on forcing nut.

7) Tighten forcing nut until spring is compressed enough to be free in its seat. Remove 2 lower arm pivot bolts, disengage lower arm from frame crossmember, and remove coil spring.

8) If a new spring is to be installed, mark position of compression tool plates on spring with chalk. Loosen forcing nut to relieve spring tension and remove compression tool.

**Installation** — To install, reverse removal procedures, noting the following: Before compressing spring, be sure upper ball nut securing pin is inserted properly. Compress spring to same height as removal. Ensure that coil spring tail is positioned properly. See Fig. 4.

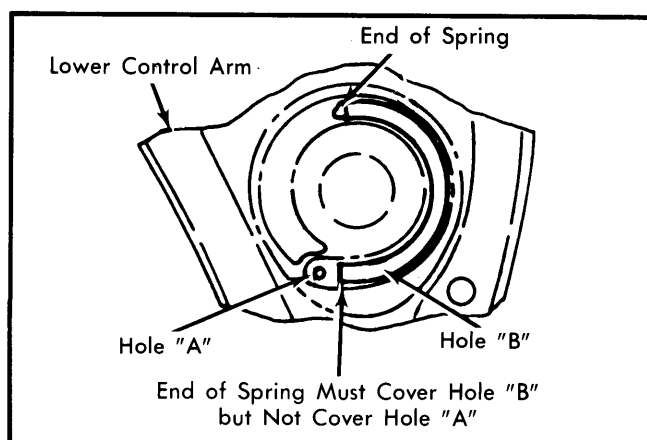

**Fig. 4 Coil Spring Positioning on Lower Control Arm**

### LOWER CONTROL ARM

**Removal** — 1) Raise front of vehicle and place safety stands under both sides of frame just behind lower control arms. Remove wheel and tire.

2) Remove brake caliper, rotor and dust shield. Remove shock absorber. Disconnect stabilizer bar link from lower arm. Disconnect steering center link from pitman arm. Remove cotter pin from lower ball joint nut.

3) Loosen ball joint stud nut 1 or 2 turns. DO NOT remove nut from stud. Install ball joint press tool (T57P-3006-B) between upper and lower ball joint studs.

4) Using a wrench, turn adapter screw until stud is under tension. Tap spindle with a hammer near lower stud to loosen stud. Remove tool. Place floor jack under lower arm.

5) Install coil spring compression tool as outlined previously, and remove spring. Remove ball joint nut and remove lower control arm assembly.

**Installation** — To install, reverse removal procedures noting the following: Position ball joint stud into spindle and tighten nut, installing a new cotter pin. Position coil spring in upper spring pocket and raise lower arm, aligning holes in arm with holes in crossmember. Ensure pigtail of lower spring coil is in proper position on seat.

# Front Suspension

## FORD MOTOR CO., ENCLOSED SPRING (Cont.)

### UPPER CONTROL ARM

**Removal** — 1) Raise front of vehicle and position safety stands under both sides of frame just back of lower arms. Remove wheel and tire from hub, then loosen stud nut on upper ball joint one or two turns. DO NOT remove nut from stud at this time. Install suitable tool (T57P-3006-B) between upper and lower ball joint studs with adapter screw on top. Tool must be firmly seated against ends of both studs and NOT against stud nuts.

2) Turn adapter screw with wrench until tool places stud under tension. Tap spindle near upper stud with hammer to loosen stud in spindle. DO NOT loosen stud from spindle using tool pressure only. Remove tool from between ball joint studs and place floor jack under lower arm. Remove upper arm attaching bolts, and remove upper arm assembly.

**Installation** — To install reverse removal procedures noting the following: Transfer bumper from old arm to new arm. Adjust caster, camber and toe-in to specification.

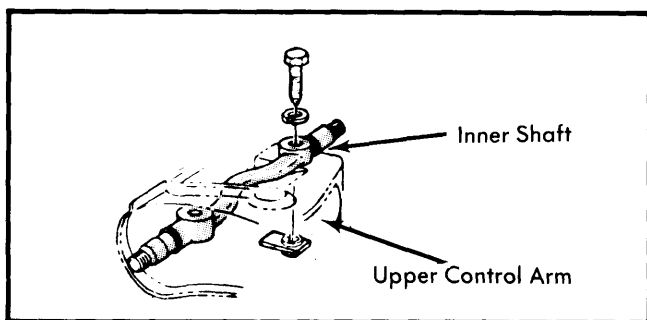

Fig. 5 Exploded View of Upper Control Arm Inner Shaft

### UPPER CONTROL ARM BUSHINGS

**Removal** — Remove nuts and washers from both ends of upper control arm shaft. Using suitable tool (T74P-3044-A-1), remove bushings from control arm. Repeat procedure for other side.

**Installation** — Position shaft and new bushings in upper control arm and press bushings into upper control arm. Position inner shaft so that serrated side contacts frame. Install inner

washer, rear bushing only, and 2 outer washers with new nuts on each end of inner shaft.

**NOTE** — Front bushing is larger than rear. Use adapter tool (T79P-3044-A2), to install rear bushing.

### FRONT WHEEL SPINDLE

**Removal** — 1) Raise vehicle and place safety stands under both sides of frame just behind lower arm. Remove wheel and tire. Remove brake caliper, rotor and dust shield. Disconnect tie rod end from spindle with tool (3290-C or equivalent).

2) Remove cotter pins from both ball joint stud nuts. Loosen nuts one or two turns, but DO NOT remove nuts at this time. Position ball joint remover tool between upper and lower ball joint studs. Tool should seat firmly on ball joint studs and NOT on stud nuts.

3) Turn tool with a wrench until tool places studs under considerable pressure. With a hammer hit the spindle near studs to break them loose in spindle. DO NOT attempt to loosen studs with tool pressure only. Position a floor jack under the lower arm. Remove upper and lower ball joint stud nuts, lower jack and remove spindle.

**Installation** — To install, reverse removal procedure. If spindle is being replaced because of accident damage, check wheel alignment.

### TIGHTENING SPECIFICATIONS

Application	Ft. Lbs.
Lower Arm-to-Crossmember .....	120-140
Upper Arm-to-Frame .....	120-140
Lower Arm-to-Bumper .....	29-35
Stabilizer Bar-to-Lower Arm .....	9-12
Ball Joint-to-Spindle	
Upper .....	75-90
Lower .....	100-120
Stabilizer Bar-to-Frame .....	14-26
Shock Absorber	
Upper .....	26-30
Lower .....	15-18