

## FORD MOTOR CO. MACPHERSON STRUT

Escort  
Lynx

### DESCRIPTION

The front wheel drive front suspension is a MacPherson Strut design with cast steering knuckles. The shock absorber strut assembly includes a rubber top mount and a coil spring insulator mounted on the shock strut. The strut assembly is attached at the top to the body side apron, and at the bottom to the steering knuckle.

A pinch joint is designed into the knuckle. The lower arm is attached to the underbody side apron, the steering knuckle and the stabilizer bar. The drive shaft outer stub shaft and wheel hub are attached inside the steering knuckle hub by a pressed fit of mating splines. The assembly is secured by a staked nut on the end of the stub shaft.

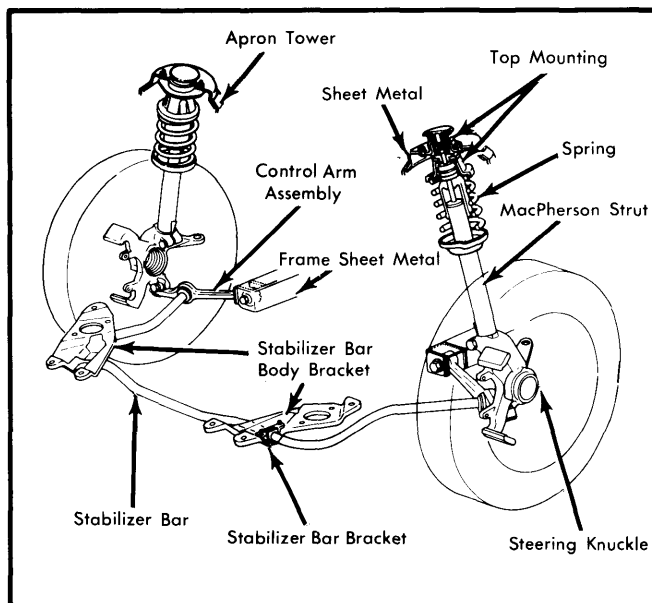

**Fig. 1 Exploded View of Ford Motor Co. MacPherson Strut Suspension**

### ADJUSTMENT

#### CASTER & CAMBER

See *Caster and Camber Adjustments and Specifications in WHEEL ALIGNMENT Section.*

#### RIDING HEIGHT

See *Riding Height Adjustments in WHEEL ALIGNMENT Section.*

#### FRONT WHEEL BEARINGS

See *Wheel Bearing Adjustment in WHEEL ALIGNMENT Section.*

#### BALL JOINT CHECKING

See *Ball Joint Checking in WHEEL ALIGNMENT Section.*

### REMOVAL & INSTALLATION

#### BALL JOINTS

**NOTE** — *Ball joints are not replaceable individually. Lower control arm and ball joints must be replaced as an assembly.*

#### STABILIZER BAR AND/OR INSULATORS

**Removal** — Raise vehicle on hoist. Remove nut from stabilizer bar at each lower control arm and pull off large dished washer. Remove stabilizer bar insulator mounting bracket bolts and remove stabilizer bar. Carefully cut worn insulators from bar.

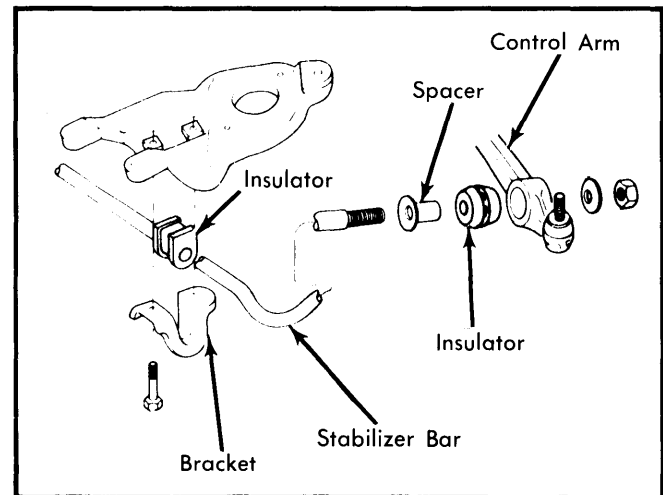

**Fig. 2 Exploded View of Stabilizer Bar**

**Installation** — To install, reverse removal procedure noting the following: Coat new insulators and stabilizer bar with Ruglyde, or equivalent lubricant.

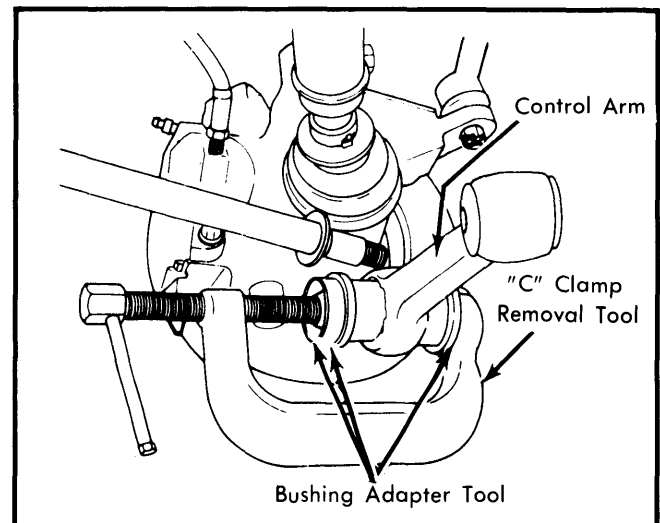

**Fig. 3 Removing Stabilizer Bar Bushings**

## FORD MOTOR CO. MACPHERSON STRUT (Cont.)

### STABILIZER BAR/CONTROL ARM INSULATOR

**Removal** — Raise vehicle on hoist. Remove stabilizer bar-to-control arm nut and dished washer. Remove control arm inner pivot nut and bolt and pull arm down from underbody and away from stabilizer bar. Using "C" clamp removal tool and adapter, remove old insulator bushing from control arm.

**Installation** — To install, reverse removal procedure noting the following: Saturate new bushings and lower arm with vegetable oil. DO NOT use any type of petroleum or mineral based oil. Tighten installing tool slowly until bushing pops into place.

### LOWER ARM PIVOT BUSHING

**Removal** — Raise vehicle on hoist. Remove stabilizer bar-to-control arm nut and dished washer. Remove control arm inner pivot nut and bolt and pull arm down from underbody and away from stabilizer bar. Using sharp knife, cut away retaining lip of bushing prior to removal. Using "C" clamp removal tool and adapter, remove old bushing from control arm.

**NOTE** — This operation can be done in vehicle without removing arm from knuckle.

**Installation** — To install, reverse removal procedure noting the following: Saturate new bushings with vegetable oil before installation. DO NOT use any type of petroleum or mineral based oil.

### LOWER CONTROL ARM

**Removal** — 1) Place ignition key in unlocked position. Raise vehicle on hoist. Remove nut from stabilizer bar. Pull off large dished washer. Remove lower control arm inner pivot bolt and nut.

2) Remove lower control arm ball joint pinch bolt. Using screwdriver, slightly spread knuckle pinch joint and separate control arm from steering knuckle. A drift punch may be used to remove production bolt. DO NOT use hammer to separate ball joint from knuckle.

**Installation** — To install, reverse removal procedure noting the following: Make sure ball stud groove is properly positioned. Use new bolts and nuts on reassembly.

### STEERING KNUCKLE

**Removal** — 1) Place ignition key in unlocked position. Raise vehicle on hoist. Remove tire and wheel. Remove cotter pin from tie rod end stud and remove slotted nut. Using suitable removal tool, remove tie rod end from steering knuckle.

2) Remove brake caliper. Remove hub from driveshaft. Remove lower arm-to-steering knuckle pinch bolt and nut with a drift punch. Using screwdriver, slightly spread knuckle to lower arm pinch joint and remove lower arm from knuckle. DO NOT use a hammer to separate ball joint from knuckle.

3) Remove shock absorber strut-to-steering knuckle pinch bolt. Using screwdriver, slightly spread knuckle-to-strut pinch joint. Remove knuckle from shock absorber strut.

4) Place assembly on bench and remove seals and bearings. Remove rotor splash shield from knuckle.

**Installation** — To install, reverse removal procedure noting the following: Use new nuts and bolts on reassembly. Make sure ball stud groove is properly positioned.

### SPRING, STRUT AND UPPER MOUNT

**Removal** — 1) Raise vehicle and place safety stands under jack pads rearward of wheels. Remove tire and wheel. Remove brake line flex hose clip from strut. Place floor jack under strut and raise strut as far as possible without raising vehicle.

2) Install suitable spring compressor tool by placing top jaw of tool on second coil from top of spring and bottom jaw so it grips a total of 5 coils. Compress spring until there is  $\frac{1}{8}$ " between any 2 coils.

**NOTE** — When using spring compressor, oil must be placed on threads. Use hand tools only, no impact tools. The spring must be compressed evenly from side to side.

3) Remove steering knuckle-to-strut pinch bolt. Loosen, but do not remove, 2 top mount-to-apron nuts. Lower jack away from lower control arm.

4) Place a piece of wood (2" x 4" x 7 $\frac{1}{2}$ ") against shoulder of knuckle. Using a short pry bar between wood block and lower spring seat, separate strut from knuckle. Remove 2 top mounting nuts. Remove strut, spring and top mount assembly from vehicle.

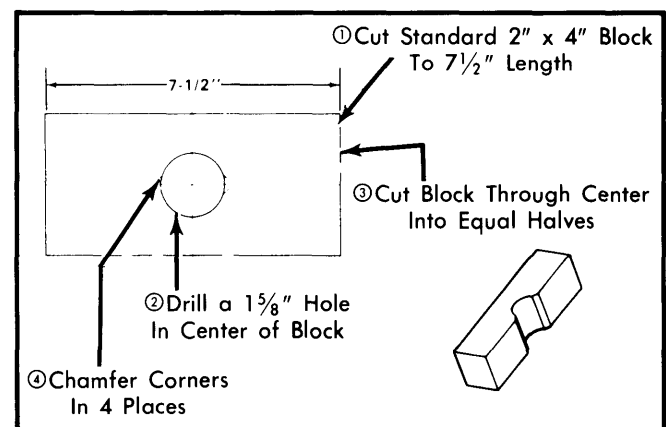

Fig. 4 Fabricating Wood Block

5) Place an 18 mm deep socket on strut shaft nut. Insert a 6 mm Allen wrench into shaft end and clamp mount in vise with wood blocks as shown in Fig. 5.

## FORD MOTOR CO. MACPHERSON STRUT (Cont.)

6) Remove top shaft mounting nut while holding Allen wrench with vise grips. Remove strut top mount components and spring.

**NOTE** — If only strut or top mount is to be serviced, do not remove compressor tool from spring.

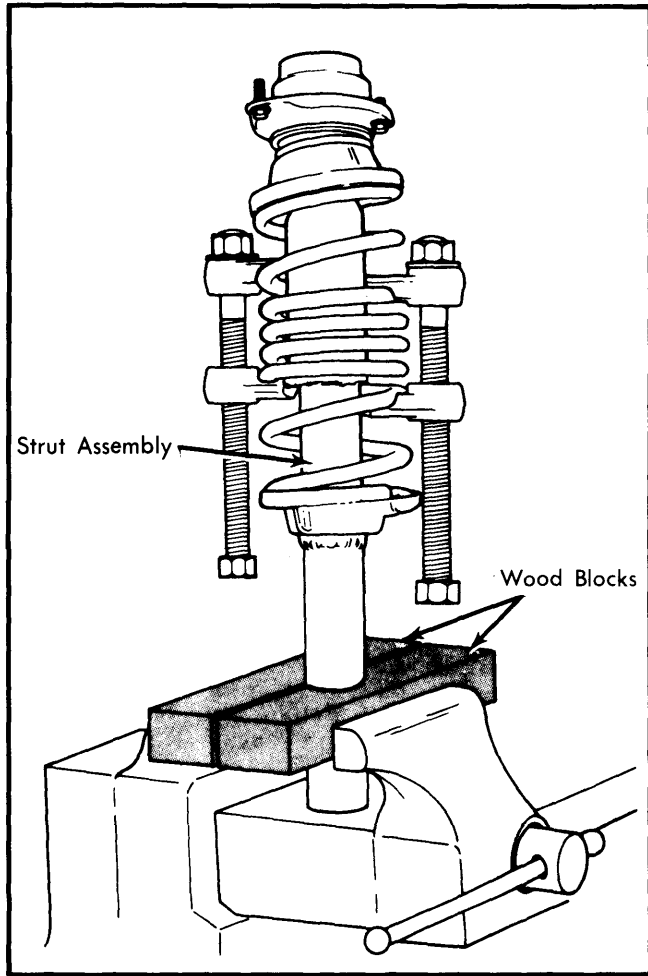

**Fig. 5 Positioning Strut Assembly and Wood Blocks in Vise**

**Installation** — To install, reverse removal procedure noting the following: Be sure that pigtail of spring is indexed in spring seat. Compressor tool must be positioned 90° from metal tab on lower part of strut. Bearing and seal must be positioned properly or damage to bearing will result.

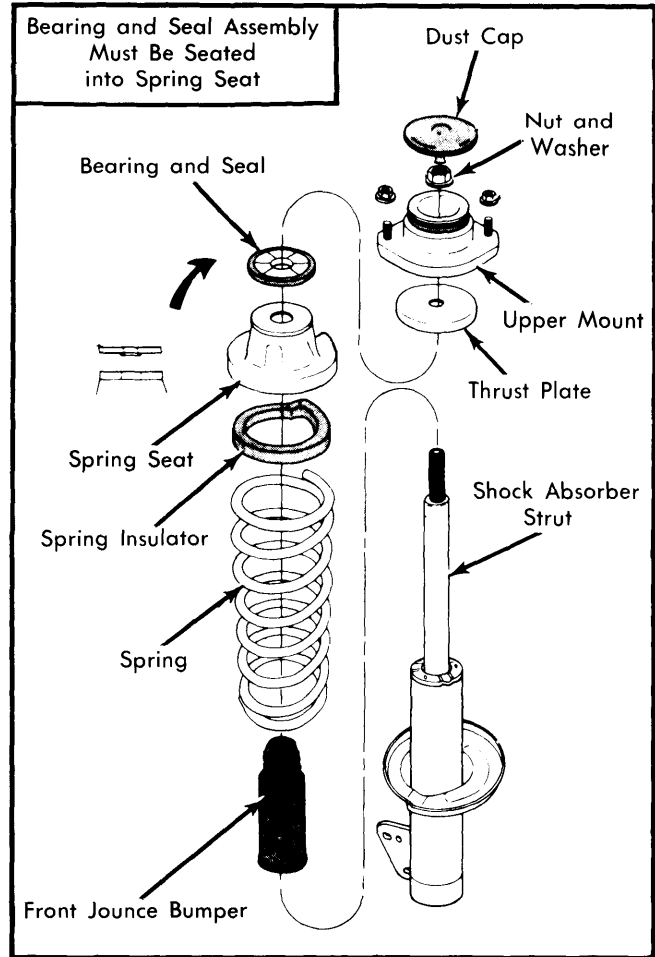

**Fig. 6 Exploded View of Top Mount Components**

### TIGHTENING SPECIFICATIONS

Application	Ft. Lbs.
Lower Control Arm-to-Body .....	44-55
Lower Control Arm Pinch Bolt .....	37-44
Stabilizer Bar-to-Control Arm .....	59-73
Stabilizer Bar Bracket-to-Body .....	50-60
Shock Absorber Shaft Nut .....	48-62
Shock Absorber-to-Knuckle .....	66-81
Steering Knuckle Pinch Bolt .....	68-81
Tie Rod-to-Steering Knuckle .....	23-35
Upper Mount Attaching Nuts .....	22-29