

FORD MODEL C-II

Ford Motor Co.

REMOVAL & INSTALLATION

DESCRIPTION

The C-II pump is belt driven and has an integral fiberglass nylon reservoir. Spring loaded slippers within cam and rotor create pumping action. A flow control/relief valve maintains pump volume and pressure. The pump design incorporates a pump pressure fitting which allows the pump pressure line to swivel; this is normal and does not indicate an undertightened fitting. An identification tag attached to the reservoir body indicates the pump model. Use model code when requesting service parts in case of differences in internal components.

POWER STEERING PUMP

Drain reservoir fluid by disconnecting fluid return line at reservoir. Disconnect pressure hose at pump and remove bolts from mounting bracket. Remove drive belt from pulley and pump from bracket. To install, reverse removal procedure, adjust belt tension, refill and bleed pump. See *Power Steering General Servicing* in this section for correct procedures.

NOTE — Do not pry against the reservoir to tighten belt. Pressure on the fiberglass may crack the reservoir.

POWER STEERING PUMP PULLEY

Drain as much fluid as possible from pump through filler pipe. Install suitable pulley remover tool (T75L-3733 or equivalent) on pulley hub and remove pulley. To install, reverse removal procedure.

CAUTION — Pulley must be removed without in and out pressure on shaft to prevent damage to internal thrust areas.

LUBRICATION, TROUBLE SHOOTING & TESTING

See *Power Steering General Servicing* in this section.

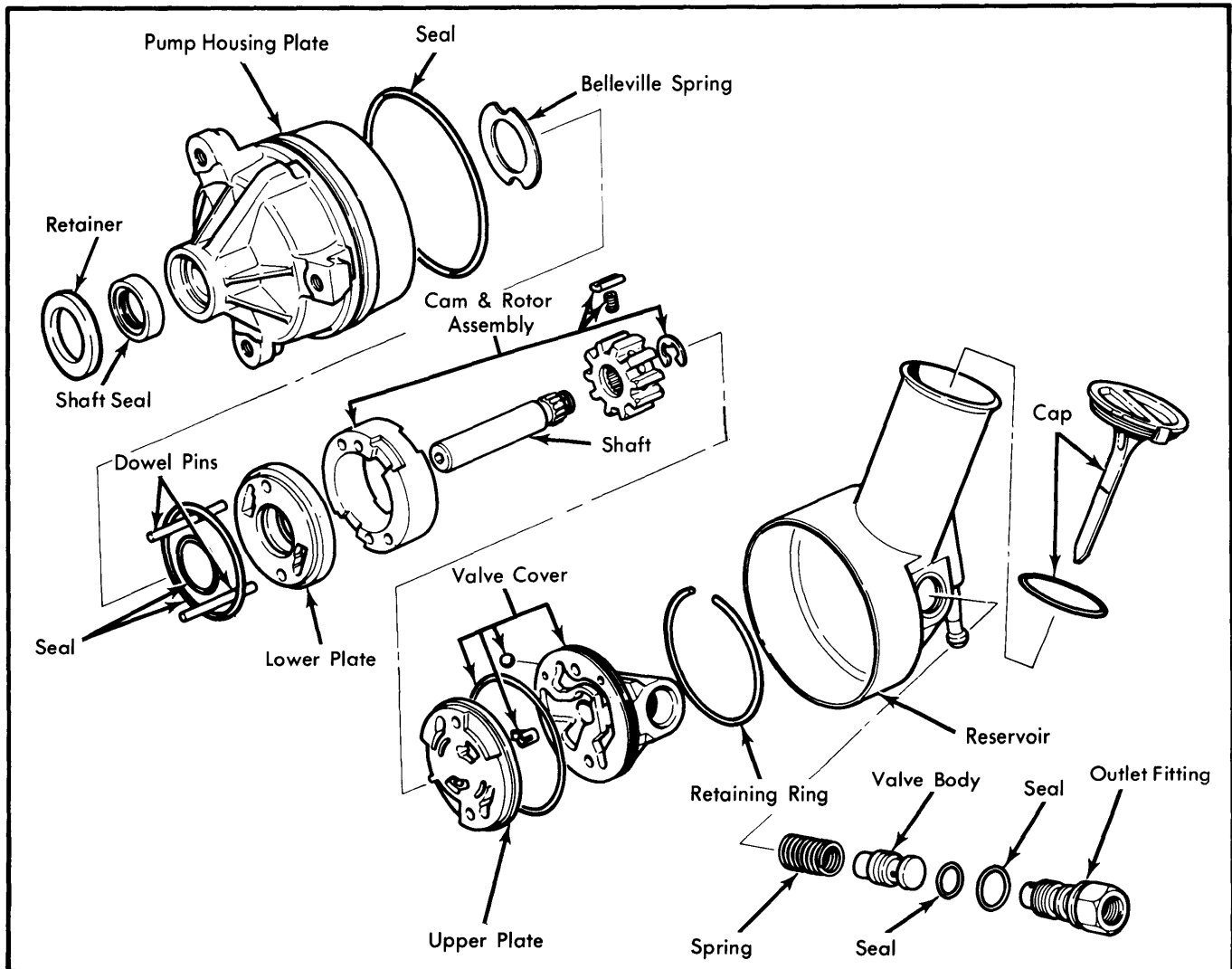

Fig. 1 Ford Model C-II Steering Pump

FORD MODEL C-II (Cont.)

ROTOR SHAFT SEAL

Remove pulley and install pump assembly in a vise, pulley end of shaft up. Clean any rust or dirt from shaft. To prevent scoring of shaft, wrap .005" shim stock (free of burrs) around rotor shaft and push it into ID of the seal until it is against bushing. Remove rotor shaft seal and seal retaining ring simultaneously by prying out with a screwdriver. Install rotor seal using suitable tool (T78P-3733-A3 or equivalent). Using plastic mallet, drive seal into bore until bottomed. Install seal retainer in same manner.

OVERHAUL

Disassembly – Remove outlet fitting, flow control valve and spring, and remove reservoir from pump. Mount large "C" clamp vertically in vice with screw at top. Place rotor shaft in lower support plate tool T78P-3733-A2 and compressor plate tool T78P-3733-A1 (or equivalent tools) into upper portion of "C" clamp. Insert pump (shaft down) into clamp and tighten until slight bottoming of valve cover is felt. Push inward on retaining ring through hole in side of pump housing to lift and remove retaining ring. Remove pump from clamp and lift cover off. Push on rotor shaft to remove shaft, upper plate, rotating group assembly and two dowel pins. To remove cover plate and Belleville spring, slam pump housing on flat surface. Pry rotor shaft seal from housing.

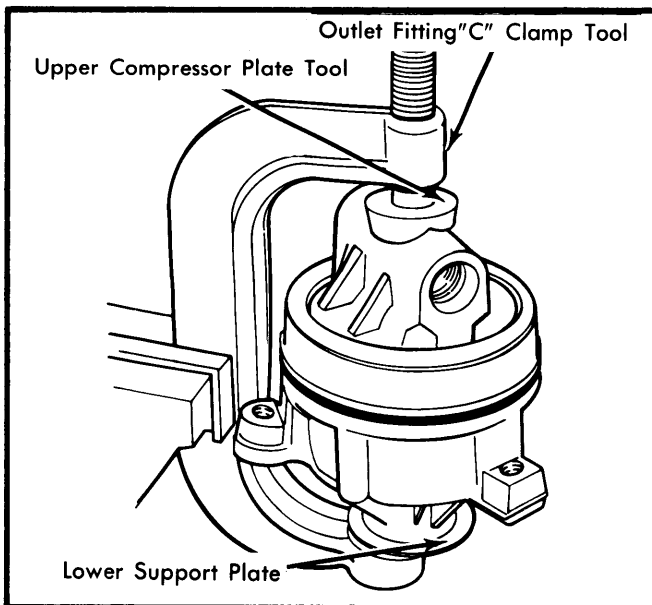

Fig. 2 Pump Positioned in "C" Clamp

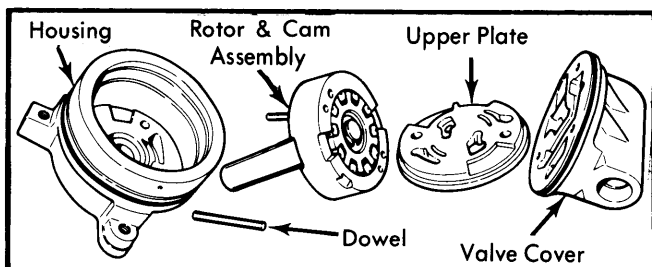

Fig. 3 Disassembled Pump

Reassembly – 1) If rotating group was disassembled, place rotor on shaft with triangle detent (See Fig. 4) facing upwards and install retaining ring at end of shaft. Place insert cam over rotor with recessed notch on cam facing upwards.

2) With rotor extended approximately half way out of cam, insert springs and slippers (groove facing outward) into rotor cavities beneath recessed cam flats. Index cam either one space right or left at a time about rotor and insert remaining springs and slippers until all 10 cavities are filled. Use care when turning rotor that previously installed springs and slippers do not fall out.

3) Using suitable adhesive on outside of seal and primer in seal bore, drive rotor shaft seal into bore with driver tool T78P-3733-A3 (or equivalent). With pulley side of housing facing down, insert two dowel pins and Belleville spring (dished surface upward) into housing.

4) Lubricate inner and outer "O" rings with power steering fluid and install on lower pressure plate. Insert lower pressure plate over dowels and into housing with seals facing front of pump. Use driver tool (T78P-3733-A3) and "C" clamp to press lower plate into housing until it is felt to bottom.

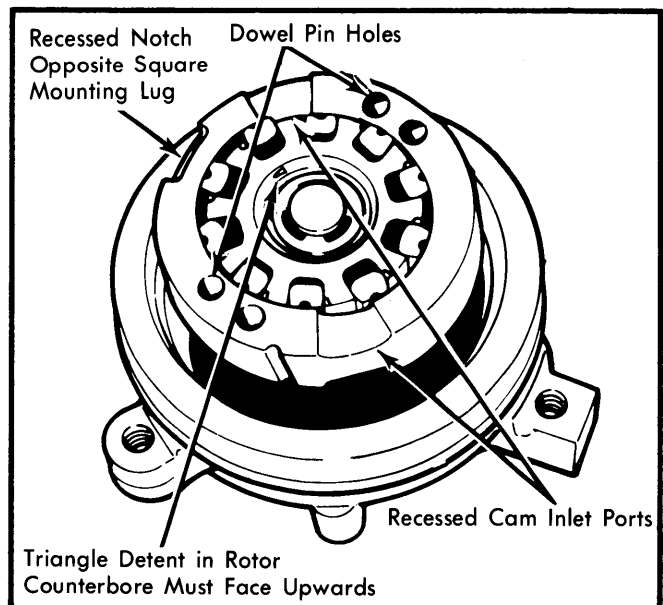

Fig. 4 Assembling Cam and Rotating Assembly

5) Install rotating assembly over dowel pins and into housing as shown in Fig. 4. Place upper pressure plate over dowel pins with recess directly over recessed notch on cam insert as shown in Fig. 5.

NOTE – Stepped holes must be used for dowel pins and the recessed notch in cam insert must face toward the reservoir approximately 180° opposite the square mounting lug on housing.

FORD MODEL C-II (Cont.)

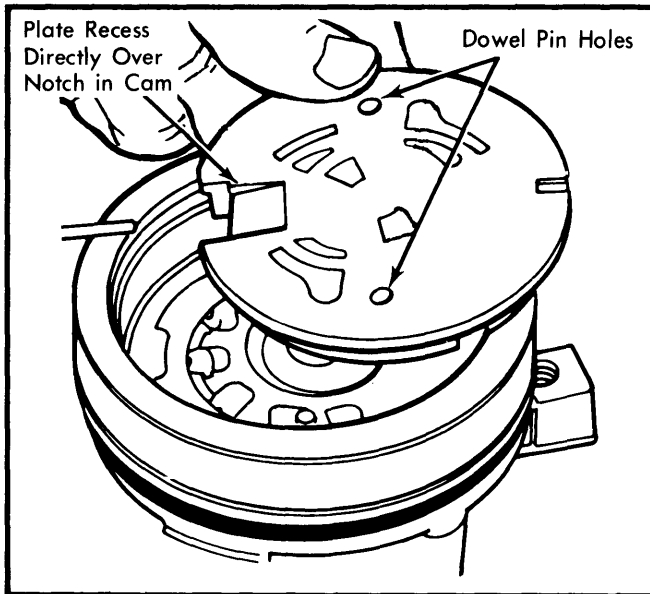

Fig. 5 Upper Pressure Plate Installation

6) Lubricate and place new "O" ring on valve cover. If plastic baffle is loose in valve cover, apply petroleum jelly to baffle and install into position on valve cover. Insert valve cover over dowel pins with outlet fitting hole directly in line with square

mounting lug on housing. Place assembly in "C" clamp and compress valve cover into pump housing. Install retaining ring with ends near access hole in housing.

7) Lubricate and install "O" ring on pump housing and install reservoir. Install flow control valve and spring into valve cover. Use new "O" ring seals on outlet fitting and install into valve cover to specified torque.

NOTE — If flow control valve is cocked, it may become stuck in valve cover. Do not force valve forward since chips may shear off and carry into valve bore.

TIGHTENING SPECIFICATIONS

Application	Ft. Lbs.
Pivot Bolt	30-45
Pump-to-Bracket	30-45
Bracket-to-Engine	30-45
Pressure Hose-to-Pump Nut	12-15
Outlet Fitting	24-35
Belt Adjusting Bolts	Ⓢ25-40

Ⓢ — Adjust to Proper Belt Tension