

GENERAL MOTORS TILT & TILT-TELESCOPE

DESCRIPTION

Two types of movable steering columns are used by General Motors. First type is the tilt steering column with six different steering wheel angle positions. The second type column tilts and also telescopes for driver ease of entry and comfort.

REMOVAL & INSTALLATION

The removal and installation procedures for tilt and tilt-telescope columns are the same as standard steering columns. See *General Motors Collapsible Steering Columns* in this section. **NOTE** — Removal is not necessary to service column upper end components.

DISASSEMBLY

NOTE — Once the steering column is removed from vehicle, it is extremely susceptible to damage. Dropping column on its end could collapse steering shaft or loosen plastic injections which maintain column rigidity. Leaning on mast jacket may cause jacket to bend or deform. When removing steering wheel, use a standard puller but do not hammer on puller to aid steering wheel removal as damage to column may result.

STEERING COLUMN

1) Disconnect battery ground cable and remove steering wheel. Remove column if necessary; steps one through seven can be performed without removing column from vehicle. Remove rubber bumper and carefully remove plastic retainer from lock plate. Install suitable tool (J-23063) on steering shaft and remove lock plate "C" ring; discard ring and install new one during reassembly. Remove lock plate, cancelling cam

and upper bearing preload spring. Remove column lower trim panel if equipped. Disconnect turn signal connector from harness and tape wires back along connector to keep wires flat during removal. Remove four bolts attaching bracket assembly to column jacket. Remove shift indicator cable attaching screw (if equipped).

2) Remove both bracket nuts while holding column up, remove bracket and wire protector from turn signal wiring, then loosely install bracket and nuts to hold column in place. Position turn signal lever in right turn position, unscrew lever and remove. Lift tilt lever and set column in center position. Push in hazard warning knob, remove screw and knob. Remove signal switch screws and carefully pull switch and wiring from column.

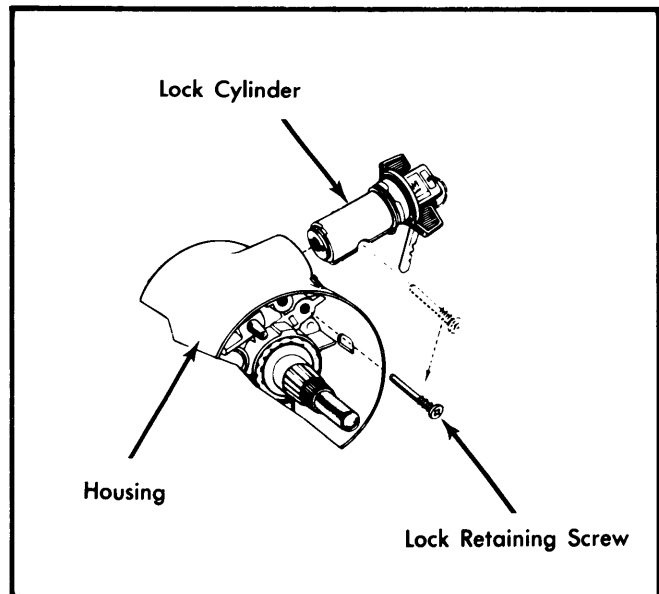

Fig. 1 Ignition Lock Cylinder Removal

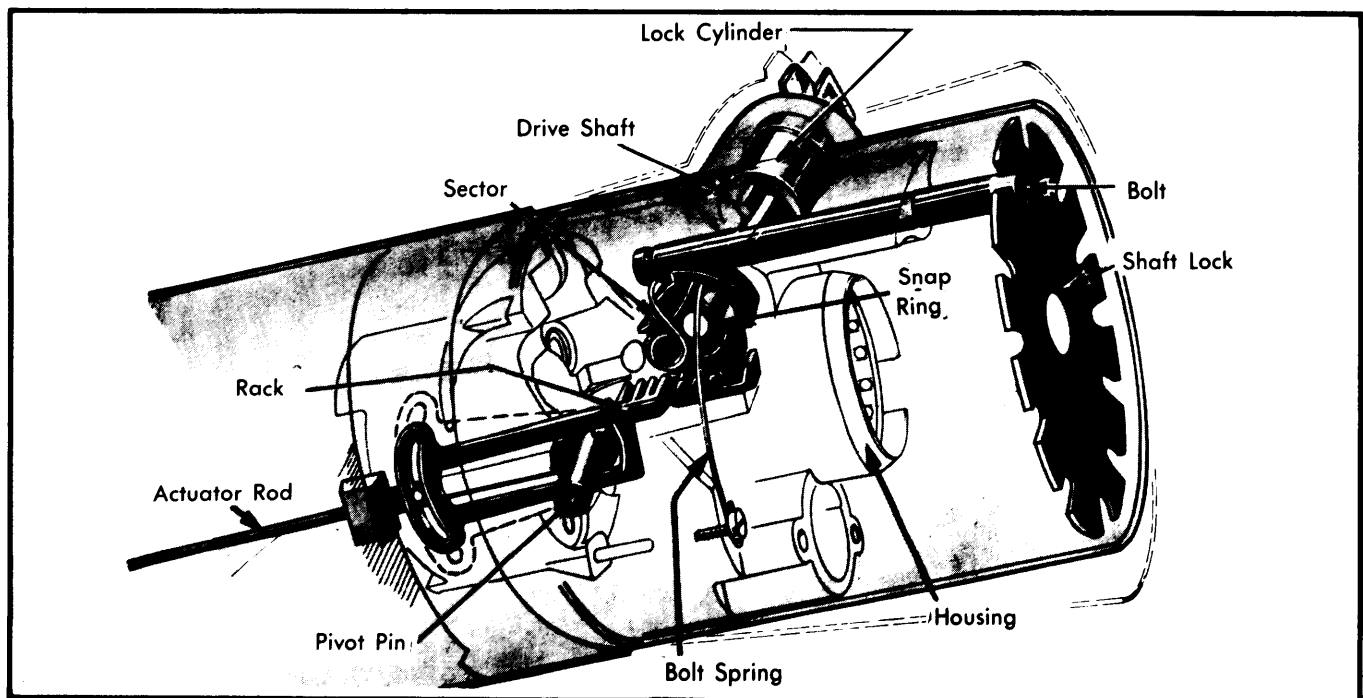

Fig. 2 Steering Locking Mechanism (Locked Position)

Movable Steering Columns

GENERAL MOTORS TILT & TILT-TELESCOPE (Cont.)

3) Turn ignition switch to "Run" position, remove key warning buzzer switch and screw securing lock cylinder, remove lock cylinder by pulling out. **CAUTION** — If clip from buzzer switch drops into column, further disassembly will be required to retrieve it.

4) Remove tilt lever and cover-to-housing screws. If equipped with dimmer on column, remove cap and actuator rod. Use punch to remove pivot pin, then lift out pivot assembly. Remove lock spring screw, then move rack assembly upward. Turn spring clockwise until disconnected from steering shaft lock bolt, and remove spring. Remove sector snap ring and remove sector with a pin punch by driving out cylinder lock shaft. Lock bolt can now be removed from housing. Remove lock drive

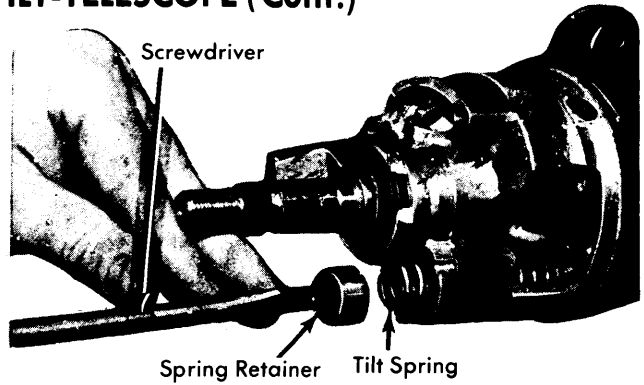

Fig. 3 Removing Tilt Spring Retainer

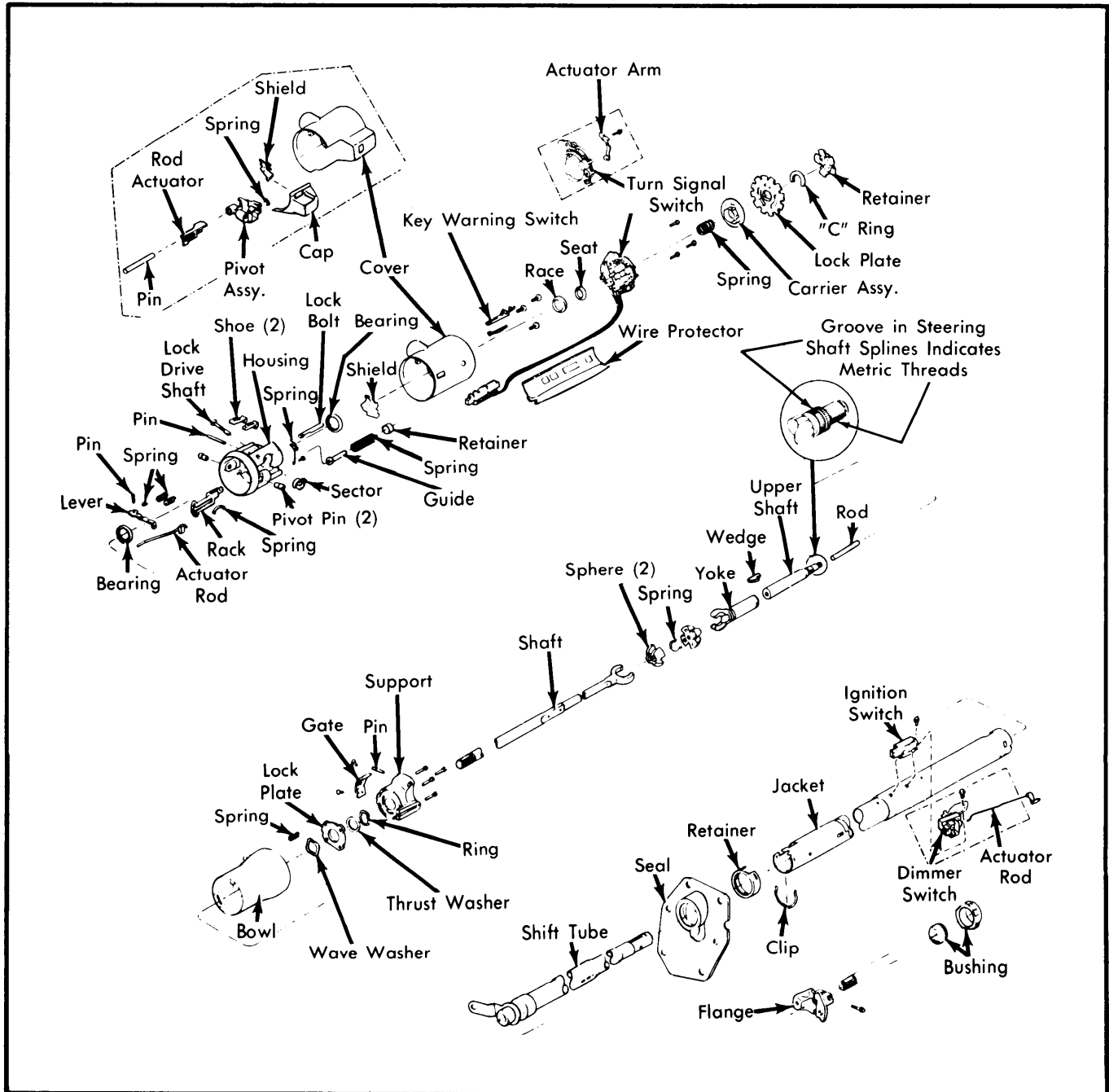

Fig. 4 Exploded View of General Motors Tilt and Tilt-Telescoping Steering Column

GENERAL MOTORS TILT & TILT-TELESCOPE (Cont.)

shaft through lock assembly opening. Install tilt lever and tilt column up. Remove tilt spring assembly using a screwdriver. Press in and turn retainer counterclockwise about $\frac{1}{8}$ turn to remove tilt spring.

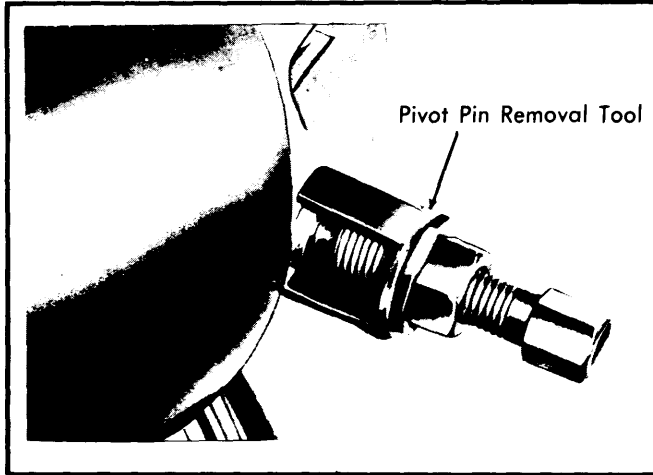

Fig. 5 Removing Pivot Pins

5) Remove housing upper bearing seat and race. Install suitable pivot pin removal tool (J-21854-1), and remove pivot pins. Lift tilt lever to release lock shoes. Pull upward on housing to extend rack fully down, then move housing to left to disengage rack from actuator and remove housing from column. Remove rack and spring from housing (do not lose spring shim if equipped). Using suitable pin punch (J-22635), drive out tilt release lever pin and remove lever and spring. Drive out lock shoe pin and remove shoes and springs.

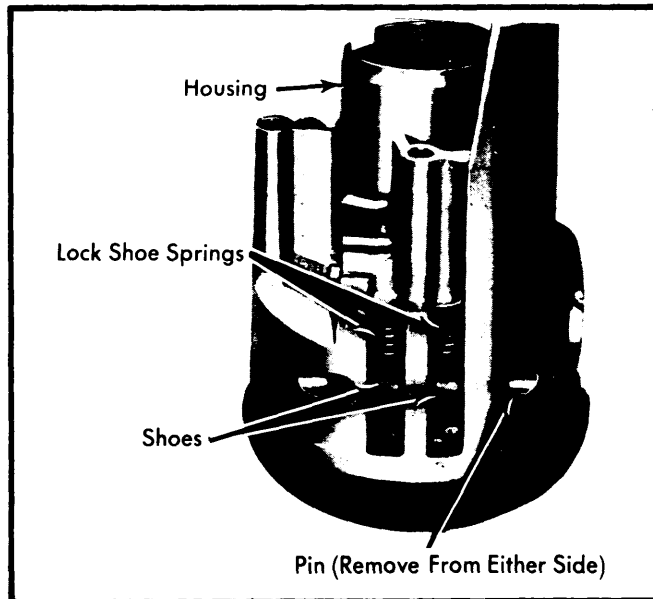

Fig. 6 Lock Shoe Mounting

6) With telescoping type columns, remove upper shaft from upper yoke by releasing locking rod and pulling shaft out. Remove locking wedge and rod. With all columns, to remove complete steering shaft assembly, disconnect and remove lower shaft coupling, bearing components and spacer (if equipped). Carefully pull steering shaft from column upper

end. **NOTE** — If service is required on yoke or centering sphere assembly only, it is not necessary to remove steering shaft completely from column. To disconnect steering shaft spheres, turn yoke 90° to centerline of lower shaft, align flats on centering sphere with lower shaft and remove upper yoke with centering sphere. Remove sphere from yoke by rotating sphere so flats align with yoke opening.

7) Remove shift lever by driving out pin and pulling lever from bowl. Remove four screws attaching support to lock plate and remove support. Remove shift gate attaching screws and remove shift gate from support. Remove ignition switch as follows: Remove toe-pan trim cover and loosen toe-pan clamp bolts. Remove nuts from column bracket and lower column. Place the ignition key lock cylinder in "LOCK" position before proceeding. **NOTE** — If lock cylinder has already been removed, the actuating rod to ignition switch should be pulled up until it stops and then pushed down one detent, which is "LOCK" position. Remove switch screws and remove ignition switch. Remove actuator rod through bowl from upper end of column.

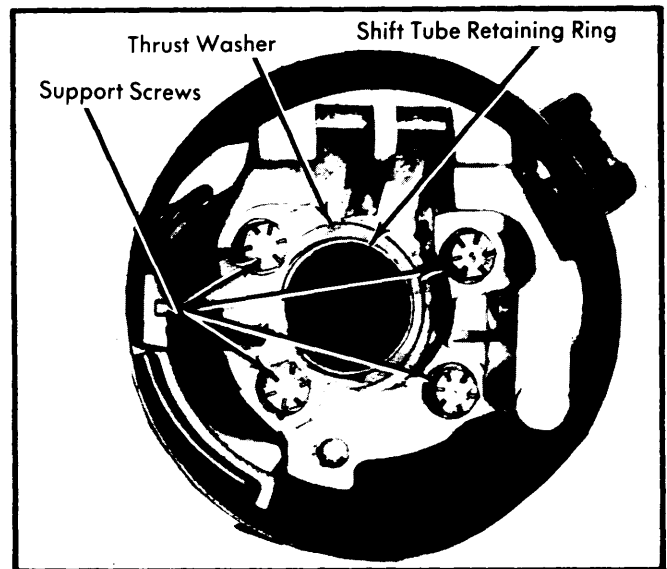

Fig. 7 Support & Shift Tube Mounting

8) The following steps for bowl and/or shift tube removal require column removal. With column removed from vehicle, remove ignition switch, neutral start and back-up switch (if equipped). Remove retaining ring, cover, bearing and adapter from column lower end. Remove shift tube retaining ring and thrust washer. Remove lower shift tube support screws (if equipped).

9) Position suitable puller (J-23072) in bowl and turn bolts into lock plate about six turns. Turn center tool bolt while guiding shift lever through slot in jacket. Separate shift tube and bowl. Mark location of lock plate and remove lock plate and wave washer. Slide shift tube out column lower end.

REASSEMBLY

CAUTION — Components and fasteners used in steering column design are important in that they can affect vehicle safety and the performance of vital systems if not serviced properly. All replacement parts must be of equal part number or equivalent quality. DO NOT use a part of lesser quality or substitute design.

GENERAL MOTORS TILT & TILT-TELESCOPE (Cont.)

STEERING COLUMN

1) Mount column in a suitable holding fixture or clamp onto two weld nuts with a vise. During reassembly, apply a thin coat of lithium grease to all friction parts. Install shift lever spring into housing if equipped. With floor shift models, install plunger. With tilt only columns, slide the gearshift lever housing onto mast jacket. With tilt-telescoping columns, install transmission control lock tube housing extension and tighten screws. Install housing cover so the three cover tabs enter slots in housing extension. Install housing onto mast jacket assembly. **NOTE** — Do not hammer on end of shift tube.

2) Install bearing support lock plate wave washer. Install bearing support lock plate sliding it under jacket opening. Slide lock plate into notches in jacket. Insert shift tube into lower end of mast jacket. Align keyway in tube with key in shift lever housing. Insert suitable shift tube installer tool (J-23073) in shift tube and turn tool to tighten swivel (see illustration). With tool installed as shown, turn nut on tool while guiding shift lever through jacket slot, and pull shift tube into housing. Remove tool.

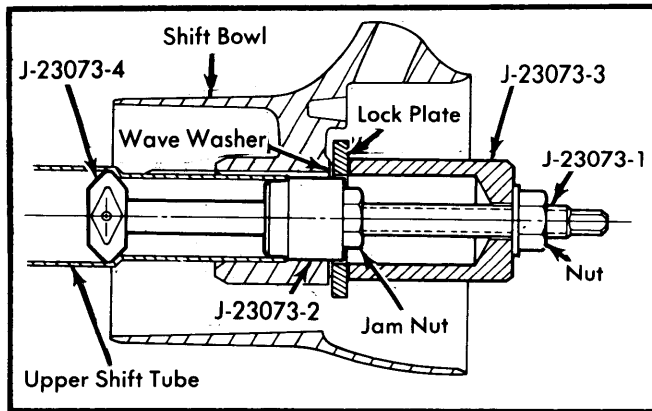

Fig. 8 Shift Tube Installer Tool

3) Install bearing support thrust washer and retaining ring by pulling shift lever housing up far enough to compress wave washer. Install bearing support by aligning "V" in support with "V" in jacket. Install and tighten screws. **NOTE** — With telescope columns, install actuator rod before tightening support screws. Install lower bearing adapter, bearing, bearing reinforcement, jacket and adapter. Install centering spheres and anti-lash spring. With telescope columns, install upper shaft, locking wedge, locking rod and bumper in upper yoke. Install steering shaft assembly in shift tube from upper end carefully guiding shaft through tube and bearing. With tilt only columns, install actuator rod through shift lever housing and insert in slot in bearing support.

4) If bearing housing was disassembled, proceed as follows: Press bearings into housing. Install lock shoe springs, lock shoes and shoe pin in housing. **NOTE** — With tilt lever opening on left side, shoes facing up, the four slot shoe is on left. Use a .180" rod to line up shoes for pin installation. Install shoe release lever, spring and pin. **NOTE** — To reduce load on release lever, hold shoes inward and wedge a block between top of shoes and bearing housing. Install sector drive shaft and lightly tap sector onto shaft and install snap ring. Install lock bolt and engage with sector cam surface. Install

rack and spring. Block tooth on rack should engage same on sector. Install external tilt release lever. Install lock bolt spring and tighten screw.

5) Extend rack downward from housing and assemble housing over steering shaft. Engage rack over end of actuator rod. With tilt release lever, hold lock shoes in the disengaged position and position housing over shaft so pivot pin holes line up. Install pivot pins using a brass drift. Place housing in full up position and install tilt spring guide, spring and retainer. Install upper bearing inner race and race seat. Install tilt and turn signal lever opening shields as equipped. Remove tilt release lever and install turn signal housing. Install tilt release lever and shift lever

6) Install 3 screws securing cover to housing assembly. Position wedge spring on buzzer switch, push switch and spring into hole in housing with switch contacts pointing up. Position turn signal switch in neutral position and install 3 screws.

7) Install hazard warning flasher button and check operation. Assemble ignition switch on actuator rod and adjust. Align key cylinder lock with keyway in housing and push lock all the way in. Install retaining screw and tighten. To complete reassembly, reverse disassembly procedure.

NOTE — All friction parts EXCEPT ignition lock assembly are to be lubricated with a light coat of lithium grease.

TIGHTENING SPECIFICATIONS

Application	Ft. Lbs.
Steering Wheel Nut	30-35
Bracket-to-Column Bolts	15-30
Bracket-to-Instrument Panel Stud Nuts	①15-25
Clamp-to-Steering Shaft Nut	
Oldsmobile Cutlass, 88, 98 & Toronado	55
Joint Assembly-to-Steering Shaft Bolt	
Oldsmobile Toronado	80
Flex Coupling Nuts	20
Flex Coupling-to-Shaft Bolt	30

① — Do not exceed 25 ft. lbs. to prevent crushing capsules.

Application	INCH Lbs.
Turn Signal Switch Screws	25-35
Ignition Switch Screws	35
Housing Cover Screws	100
Support-to-Lock Plate Screws	60
Shaft Lock Cover Screws	15
Shift Gate Screws	45
Lock Bolt Spring Screw	35
Tilt Release Lever	30
Trans. Control Lock Tube Housing	
Extension Screw	
Corvette	40