

## GENERAL MOTORS SINGLE PISTON DISC

Chevette

### DESCRIPTION

Caliper unit is constructed from a single casting which contains one large piston in inboard section of casting. Piston is constructed of nickle-chrome plated steel. Caliper unit is retained to mounting bracket by a single bolt, sleeve and bushings. Mounting bracket is bolted to rear side of steering knuckle. Brake rotor and hub are one piece. Brake rotor is cast iron using two machined braking surfaces (one on each side of rotor). Shoe and lining assemblies are constructed of stamped steel shoes with bonded linings. Inboard shoe is equipped with a spring steel wear sensor riveted to rear edge. When lining has worn to within .030" of shoe table, sensor contacts rotor, causing a very audible high frequency squeal.

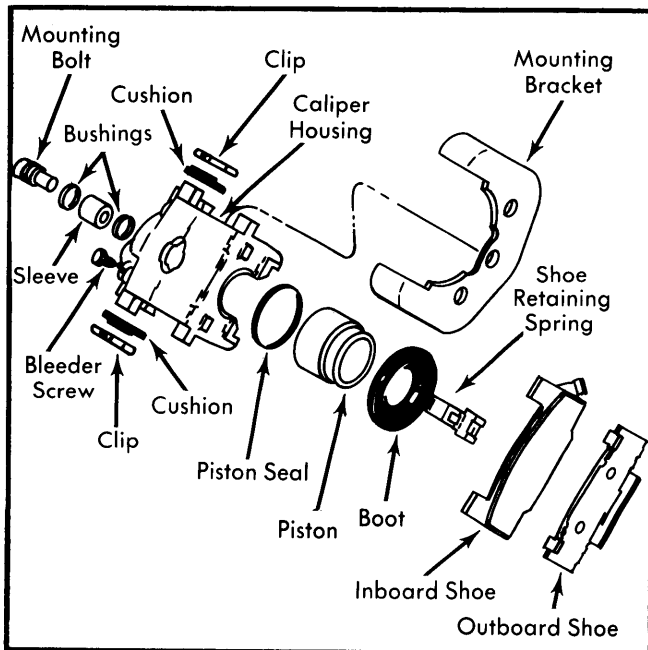

Fig. 1 Exploded View of Caliper Assembly

### ADJUSTMENT

Shoe wear is automatically compensated for by sliding caliper feature, therefore, no brake adjustment in service is required.

### SERVICING

#### BLEEDING

See Hydraulic Brake bleeding in this section.

#### SHOE & LINING INSPECTION

Inspect linings whenever a wheel is removed or tires are rotated. Check both ends of inboard and outboard linings for

wear. Replace all linings if any lining is worn to within  $\frac{1}{32}$ " of shoe table.

#### SHOE & LINING REPLACEMENT

**NOTE** — Relining should be done in complete sets only.

**Removal** — 1) Siphon and discard  $\frac{2}{3}$  of master cylinder fluid. Raise vehicle and remove front wheels. Position a large "C" clamp on caliper housing and outboard shoe and compress piston. Remove clamp.

2) Remove two hex-head bolts attaching mounting bracket to steering knuckle. DO NOT remove socket head retaining bolt. Remove caliper assembly from rotor and wire out of way. Remove old shoe and lining assemblies and retaining spring.

**Installation** — 1) Clean and inspect caliper. Check for hydraulic fluid leaks, boot cuts or other damage. Make sure caliper fits snugly in bracket without end play. If there is end play, replace or reposition rubber cushions between caliper and mounting bracket. Install shoe retaining spring on inboard shoe. Place shoes in caliper and slide assembly over rotor. Install and tighten mounting bolts.

2) Use channel lock pliers to cinch outboard shoe tabs to caliper as shown in Fig. 2. Radial and end play after cinching should be 0-.005". Install wheels and lower vehicle. Fill master cylinder and pump brakes several times to ensure a firm brake pedal.

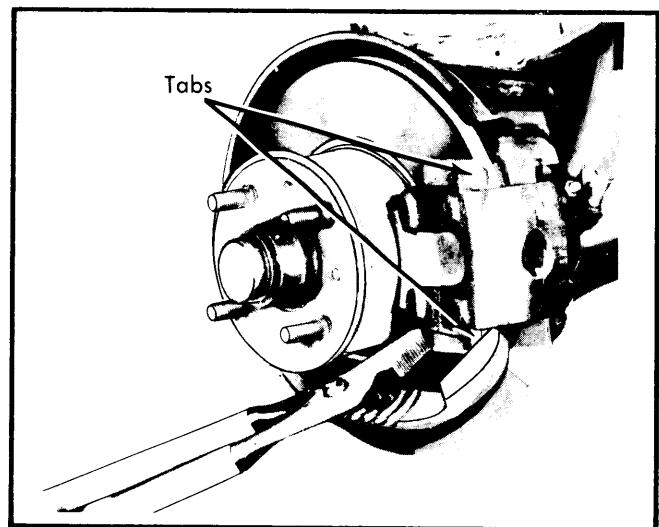

Fig. 2 Clinching Tabs of Outboard Shoe

#### ROTOR SERVICING

**Lateral Runout** — Adjust wheel bearings until all end play is eliminated. Attach a dial indicator to front suspension so that pointer contacts face of rotor approximately one inch from edge of rotor. Set gauge to zero, then turn rotor through one complete revolution noting gauge. See Rotor Specifications for maximum allowable runout.

## GENERAL MOTORS SINGLE PISTON DISC (Cont.)

**Parallelism** — Check thickness of rotor at four or more points around circumference of rotor. Make all measurements at same distance from edge of rotor. If thickness varies more than specified, refinish or replace rotor as necessary. See *Rotor Specifications for refinish thickness.*

scratches or wear and polish with crocus cloth if necessary. Clean bore thoroughly after polishing. Replace caliper if bore is not easily cleaned.

### REMOVAL & INSTALLATION

#### BRAKE CALIPER

Removal of caliper for overhaul is same procedure as for lining replacement, except it is necessary to disconnect brake hose.

**Reassembly** — 1) Lubricate bore in caliper and new piston seal with clean brake fluid. Position seal in caliper bore groove. Lubricate piston with clean brake fluid, then assemble new boot into groove in piston, with fold facing open end of piston. Insert piston into caliper bore using care not to unseat seal. Do not force piston to bottom of bore. Position outer diameter of boot in caliper counterbore, then seat boot using suitable tool (J-23572).

### OVERHAUL

#### BRAKE CALIPER

**Disassembly** — Clean exterior of caliper using clean brake fluid and place on a clean working surface, then drain brake fluid from caliper. Remove socket head retainer bolt and slide mounting bracket off caliper. Remove sleeve and two bushings. Separate clips and cushions from sides of caliper. Pad interior of caliper with shop towels and apply just enough compressed air to fluid inlet to ease piston out of bore. Remove boot from caliper with a screwdriver, then pry out piston seal using a piece of plastic or wood. DO NOT scratch piston bore by using metal tool. Remove bleeder valve from caliper.

2) Check boot installation to make sure retaining ring moulded into boot is not bent and that boot is installed completely below caliper face. Install bleeder screw. Place new cushions on caliper lugs with heavy section in lug recess and saw-toothed edges pointing outward. Liberally coat sleeve, bushings and unthreaded portion of retainer bolt with silicone grease. Place larger bushing in caliper mounting hole groove and install sleeve. Install small bushing in retainer bolt groove.

**Cleaning and Inspection** — 1) Boot, piston seal, rubber bushings and sleeve must be replaced each time caliper is overhauled. Clean all other parts in clean brake fluid and dry with filtered compressed air. Check retainer bolt for corrosion, breaks in plating or other damage. Replace if imperfections are found; do not clean.

3) Clamp caliper in a vise with mounting lug up. Place clips over cushions and squeeze mounting bracket down over clips, aligning retainer bolt hole. Considerable force may be required to fit bracket over cushions. Install and tighten retainer bolt.

2) Check outside of piston for scoring, nicks, corrosion or damaged plating. Replace if necessary. Do not use any type of abrasive as plating will be damaged. Check piston bore for

4) Install caliper on vehicle. Use new copper gasket when attaching brake hose. Bleed brake system and fill master cylinder. Lower vehicle.

### TIGHTENING SPECIFICATIONS

Application	Ft. Lbs.
Brake Hose-to-Caliper .....	32
Caliper-to-Mounting Bracket .....	28
Bracket-to-Steering Knuckle .....	70
Bleeder Screws .....	70 INCH Lbs.
Wheel Attaching Nuts .....	70

### DISC BRAKE ROTOR SPECIFICATIONS

Application	Disc Diameter	Lateral Runout	Parallelism	Original Thickness	Minimum Refinish Thickness	Discard Thickness
Chevette	9.68"	.005"	.0005"	.433"	.390"	.374"