

## FORD MOTOR CO. POWER RACK & PINION

Bobcat  
Mustang  
Pinto  
Fairmont  
Zephyr

### DESCRIPTION

Integral power rack & pinion gear is a hydraulic-mechanical unit using an integral piston and rack design to provide power assisted steering control. Internal valving directs pump flow and controls pressure to reduce steering effort. Unit contains rotary fluid control valve integrated with input shaft and a boost cylinder integral with rack. Some Fairmont and Zephyr models may use Ford built gear which combines the gear and valve housing into a one piece aluminum casting. Maintenance procedures are the same as for TRW built units except where otherwise specified.

### LUBRICATION, TROUBLE SHOOTING & TESTING

See *Power Steering General Servicing* in this section.

### ADJUSTMENT

#### RACK YOKE BEARING PRELOAD

**NOTE** — Steering gear must be removed from vehicle to perform following adjustment.

1) Clean exterior of gear thoroughly, then remove external pressure line assemblies from gear and drain fluid into a container. Attach gear to a suitable holding fixture. Mount suitable adapter (T74P-3504-R) to input shaft splines, then install an INCH lb. torque wrench (maximum capacity 30-60 INCH lbs.) to adapter.

2) Using a suitable wrench, loosen yoke plug lock nut. Position rack to center of its travel. Install yoke plug spanner wrench (T74P-3504-W) on an INCH lb. torque wrench, then

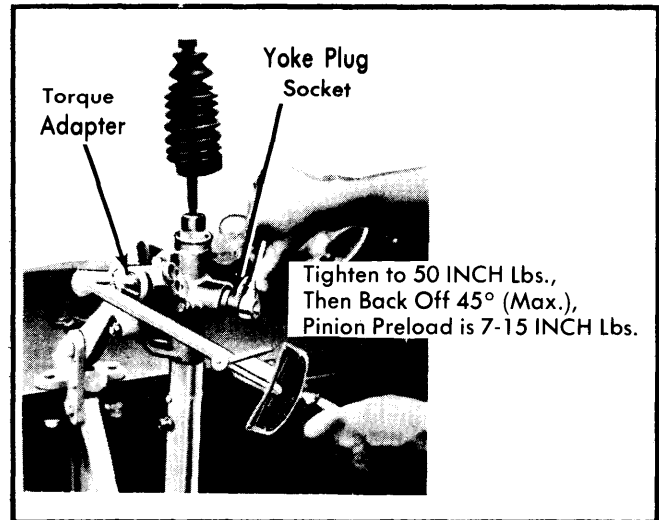

Fig. 1 Rack Yoke Bearing Preload Adjustment

place assembly into drilled holes in yoke plug. Tighten yoke plug to 45-50 INCH lbs. **NOTE** — Make sure threads of yoke plug are clean to prevent false reading.

3) Back off yoke plug (a maximum of 45°), until torque required to turn input shaft is 7-15 INCH lbs. While holding yoke plug firmly with wrench, tighten lock nut. **CAUTION** — Do not allow yoke plug to turn while tightening lock nut, or preload will be affected. Recheck input shaft torque after tightening lock nut. Remove tools, then reinstall external pressure line assemblies, using new copper flare gaskets.

**NOTE** — Ford built units incorporate quick connect lines for pressure and return lines which allow the lines to swivel. Use "O" rings or hat seals in place of copper gaskets on these, being careful not to overtorque the fittings.

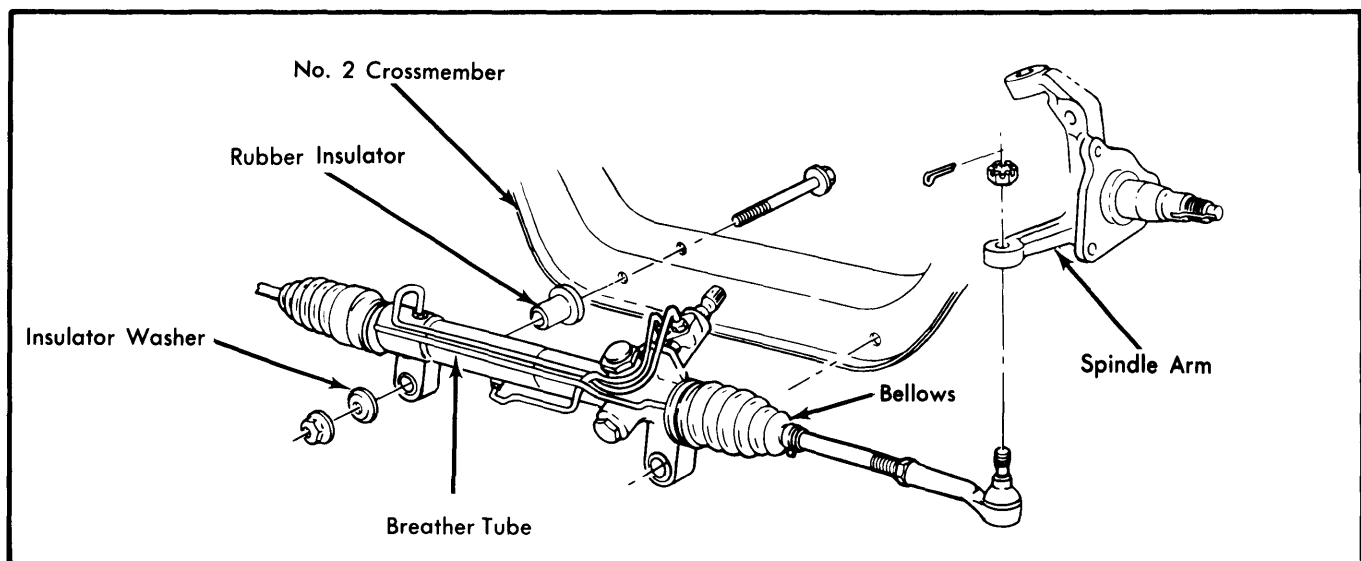

Fig. 2 Steering Gear (TRW Shown)

## FORD MOTOR CO. POWER RACK & PINION (Cont.)

### REMOVAL & INSTALLATION

#### STEERING GEAR

**Removal** — 1) Disconnect negative battery terminal, then remove bolt retaining flexible coupling to input shaft. Turn ignition switch to "ON" position, then raise and support vehicle. Remove both tie rod end retaining cotter pins and nuts, then separate studs from spindle arms using a ball joint separator tool.

2) Support gear and remove bolts securing gear to crossmember. Lower gear slightly, then remove screw securing hose bracket to gear bracket. Disconnect pressure and return lines from gear housing and plug lines to prevent entry of dirt. Remove gear from vehicle.

**Installation** — 1) Support steering gear assembly near crossmember, then install and tighten pressure and return line fittings. On Fairmont and Zephyr, hose swivel is normal. DO NOT overtighten. Install and tighten hose bracket to gear bracket screw.

2) Insert input shaft into flexible coupling, then position gear on crossmember. Install bolts, insulator washers and nuts, then tighten to specifications. Install tie rods to spindle arms, tighten and install cotter pin in retaining nuts.

3) Lower vehicle, then install bolt retaining flexible coupling to input shaft. Turn ignition key to "OFF" position, then connect negative battery terminal and remove coil wire. Fill power steering pump reservoir, then engage starter and cycle steering wheel to distribute fluid. Check fluid level and add as required. Reconnect coil wire, start engine and cycle steering wheel. Inspect seals and hoses for leaks at maximum pressure. Check and adjust wheel alignment as required. For *Wheel Alignment Specifications & Procedures*, See **WHEEL ALIGNMENT** Section.

### OVERHAUL

#### TIE ROD ENDS, BELLWS, & TIE ROD BALL JOINT SOCKETS

**Disassembly** — 1) Mount gear in a suitable holding fixture, loosen jam nuts on outer end of tie rods, then remove sockets and jam nuts. Remove four clamps retaining bellows to gear housing and tie rods, then discard clamps. Drain lubricant and remove bellows and breather tube.

2) Remove roll pin from ball joint with easy out or other suitable tool (T78P-3504-N). If pinion requires removal on Ford built gear, remove at this time in accordance with Input Shaft & Valve Assembly procedure. Hold rack on end teeth with adjustable wrench to prevent rotation and loosen ball joint nut with suitable tool (T74P-3504-U). Remove and examine all parts; replace as necessary.

**Reassembly** — 1) Install tie rods and tighten to specifications while holding rack from turning with adjustable wrench. Install new roll pins. If pinion was removed, install at this time as described in Input Shaft & Valve Assembly section.

2) Install breather tube, bellows and clamps. Crimp on clamp should be to rear (3 o'clock position) on Ford gear and on top (12 o'clock position) on TRW gear. Small clamp spring tabs should point generally downward. Install tie rod ends and jam nuts.

3) Articulation effort to move rod may be measured by placing hook of pull scale in hole of tie rod end ball stud. Effort of 1-6 lbs. should move tie rod with ball joints properly torqued. If not within specifications, replace tie rod/ball socket assembly.

#### INPUT SHAFT & VALVE ASSEMBLY

**Disassembly** — 1) Clean exterior of housing and mount in holding fixture. Remove external pressure lines and gaskets from ports on valve housing. Loosen yoke plug lock nut and yoke plug to relieve preload on rack. Remove pinion bearing plug and install adapter (T74P-3504-R) on input shaft. Hold shaft, remove and discard pinion bearing lock nut.

2) On TRW gear, remove bolts holding valve housing to gear housing. Move rack to left stop and mark position of flat (blocked tooth) on input shaft spline and valve housing face so that alignment can be maintained during reassembly. Carefully remove valve and housing assembly as a unit. Hold valve housing in hand and tap input shaft with non-metallic hammer to remove valve assembly. On Ford built units, remove input shaft dust seal using a small, sharp chisel. Remove snap ring, attach suitable puller (T78P-3504-B) and remove valve assembly.

3) Remove pinion bearing and/or lower pinion shaft seal using adapters (T78P-3504-E, T58L-101-A) with reverse hammer. On TRW units, remove input shaft support bearing with same tool. Remove oil seal with fingers and dust seal with small, sharp chisel.

4) The four plastic "O" rings are the only serviceable components of the input shaft and valve assembly. Carefully insert the point of a small pocket knife under each ring and cut it off. Avoid nicking or scratching valve lands and grooves.

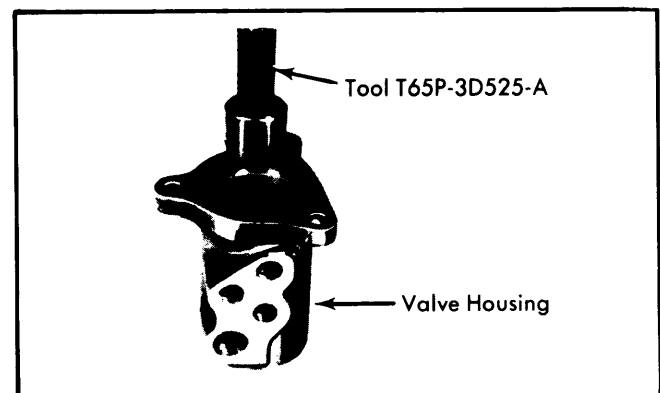

**Fig. 3** Installing Pinion Seal in Valve Housing

**Reassembly** — 1) On TRW gear, install input shaft seal with lip facing inside of housing. Use finger to press seal against bottom of bore to avoid contact with support bearing. On Ford gear, seat pinion bearing against shoulder in gear housing using suitable tool (T78P-3504-G). Lubricate pinion seal and install with lip towards tool (T78P-3504-F), seating it against shoulder.

## FORD MOTOR CO. POWER RACK & PINION (Cont.)

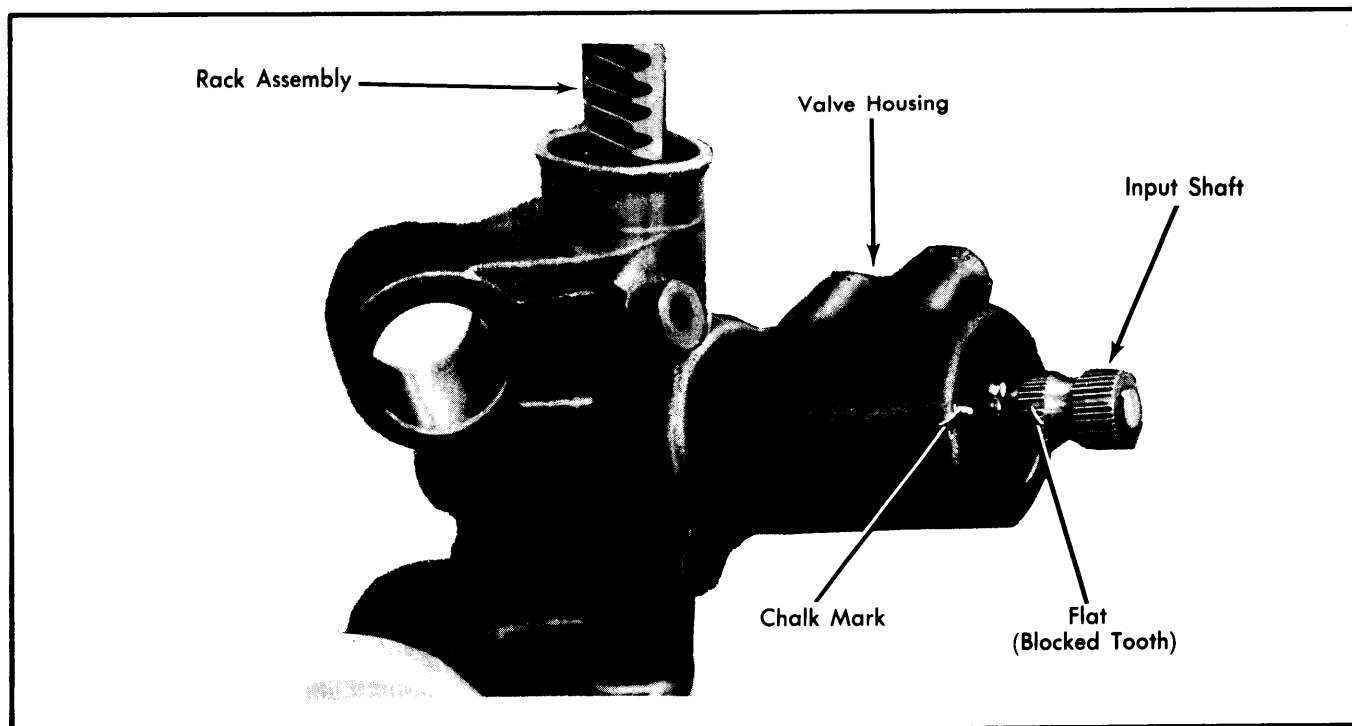

Fig. 4 Marking Tooth Piston

2) Fill input shaft dust seal bore or TRW valve housing with ESA-M145-A type lubricant and install seal with suitable replacer tool (T74P-3504-G). Lubricate input shaft support bearing with power steering fluid and install into valve housing with suitable driver (T74P-3504-G).

**NOTE**— Tool will control installation depth to prevent contact with seal.

3) Install plastic rings on grooves on valve assembly. Lubricate two thrust washers and needle bearing with power steering fluid. Install bearing with a thrust washer on each side over input shaft. Lubricate assembly with power steering fluid, then insert assembly, splined end first, into suitable installing tool (T74P-3504-H). Position assembly over valve bore of housing, then push unit through until it bottoms and full spline passes through dust seal. Remove tools.

**NOTE**— On Ford gear, use tool kit T75L-3517-A to size and install "O" rings and valve assembly, assuring that rings turn freely in grooves and are not bent over lands.

4) Install pinion seal on shaft (cup shape toward housing) and install pinion bearing in housing through plug bore (TRW gear only). Lubricate valve assembly and insert in housing in same position as when disassembled (flat of spline aligned with file or chalk mark). Install and finger tighten valve housing bolts, then tighten one turn at a time to specified torque (TRW gear).

5) Turn input spline with torque adapter (T74P-3504-R) and check for approximately 1 1/2 turns in each direction from center to stop. With rack away from stop, tighten pinion lock nut to specifications. On Ford built gear, install input shaft bearing, seal, snap ring and dust seal at this time. Install and torque steering gear housing plug.

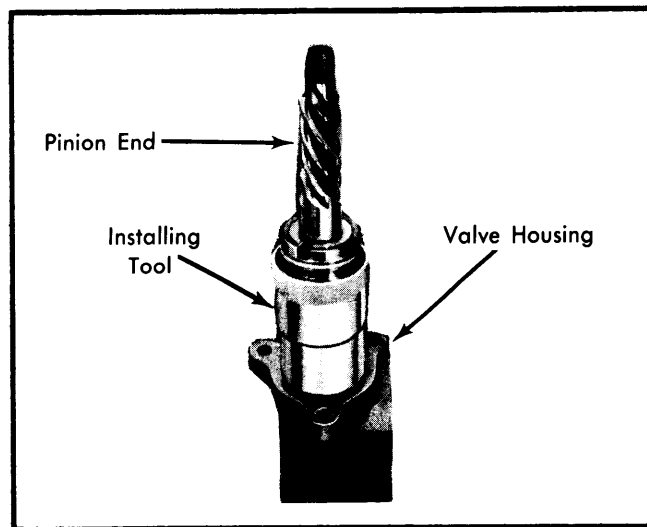

Fig. 5 Installing Valve Assembly

### GEAR HOUSING & RACK ASSEMBLY

**Disassembly** — 1) Remove tie rod and socket assemblies, lock nuts from both ends of rack, and input shaft and valve assembly. Remove yoke plug lock nut, tube bracket, and yoke plug. Remove yoke spring and yoke bearing from gear housing. Working from right side of gear housing, push rack in until it bottoms. Remove rack bushing lock nut, using suitable socket (T74P-3504-B) on TRW gear; remove snap ring from right end of Ford built housing.

# Power Steering Gears

## FORD MOTOR CO. POWER RACK & PINION (Cont.)

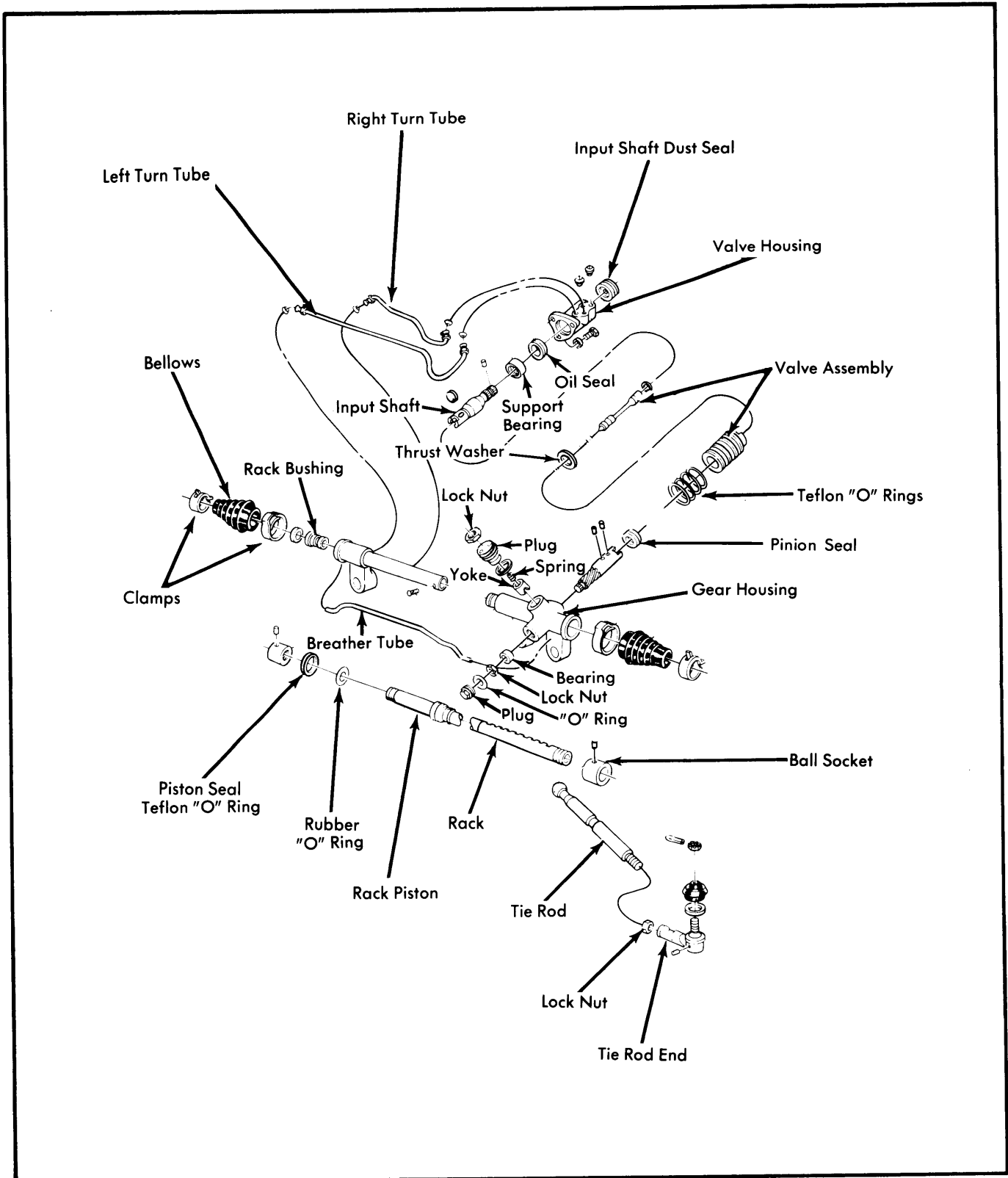

Fig. 6 Power Rack & Pinion Steering Gear

## FORD MOTOR CO. POWER RACK & PINION (Cont.)

2) Slowly pull rack from right side of housing, until rack piston contacts rack bushing. Apply pulling effort (do not hammer) on rack until bushing is removed from housing, then remove rack. Remove internal high pressure rack oil seal using suitable remover tool (T74P-3504-C). Remove Teflon "O" ring and rubber "O" ring from rack piston. Remove rack bushing oil seal by placing bushing and suitable tool (T74P-3504-E) in a vise. Remove oil seal with suitable remover tool and slide hammer. Remove rubber "O" ring from bushing.

**NOTE** — Use tools T78P-3504-J and L to remove seals from Ford built gear.

**Reassembly** — **NOTE** — Be sure the pilot nose installer tool (T74P-3504-D) and entire long protective sleeve (T74P-3504-K) are completely free of nicks or burrs. If necessary, polish tool, finishing with 600 grit wet/dry sandpaper and oil.

1) Place high pressure oil seal on suitable installer tool (T74P-3504-D for TRW units and T78P-3504-K for Ford built gear) with lip facing tool. Mark center tooth space on rack where it will be visible through valve bore to facilitate valve replacement. With gear housing in vertical position, insert installer into right side bore of housing, then tap into place. Do not cock handle during this operation. If tool binds in area of left turn pressure port, align flat on tool with pressure port. Install rubber "O" ring in groove of rack piston, then place plastic "O" ring over rubber "O" ring using suitable installer tool (T74P-3504-G).

2) Place long protective sleeve (T74P-3504-K) over rack gear teeth to protect internal oil seal. Thread short protective sleeve (T74P-3504-J) over threads on right side of rack. Lubricate plastic "O" ring and protective sleeve with power steering fluid. Install larger end of sizing tool (T74P-3504-H) onto rack tooth end of rack (TRW) or smaller end of tool (78P-3505-M) into right side of gear housing (Ford built gear).

3) Push rack into housing until leading end engages internal oil seal. Position sizing tool so it compresses plastic oil seal and guides it into housing bore. Push rack in until protective sleeve protrudes from left side of housing. Remove sizing tool and protective sleeve from end of rack. Place a ball housing lock nut on left end of rack to prevent rack teeth from damaging internal oil seal.

4) Install rubber "O" ring on aluminum rack bushing, then install high pressure oil seal in rack bushing so that lip spring faces inside of bushing using suitable installer tool (T74P-3504-F). Lubricate short protective sleeve on rack end and "O" ring seal on bushing with power steering fluid. Start bushing, seal facing out, on rack. Pass bushing and seal over protective

sleeve and into housing bore until lock nut threads are visible, then remove protective sleeve. Pass rack bushing lock nut over rack and start it into threads in housing bore.

**NOTE** — On Ford built gear, place end plate against rack bushing and apply hand pressure to tool (T78P-3504-M) until bushing seats in housing. If rack bushing will not seat with hand pressure, use a suitable deep socket and mallet to tap bushing into place. Install snap ring and remove protective sleeve. Fill yoke plug with 2 ozs. of gear lube.

5) Place a ball housing lock nut on right side of rack. Insert suitable wrench (T74P-3504-B) over exposed end of rack and into housing bore. Engage lock nut and tighten. Install yoke bearing, spring and plug, then install input shaft and valve assembly. Install tube bracket with tabs engaged in slots on gear housing. Install yoke plug lock nut. Before tightening lock nut, set rack yoke bearing preload. See *Adjustment*. Install tie rod and socket assemblies.

### TIGHTENING SPECIFICATIONS

Application	Ft. Lbs.
Pressure and Return Line Fittings .....	10-15
Gear-to-Crossmember Mounting Bolt .....	80-100
Tie Rod End-to-Spindle Arm Nut .....	ⓐ35-47
Tie Rod End-to-Tie Rod Jam Nut .....	35-50
Steering Fex Coupling Bolt .....	20-30
Yoke Plug Lock Nut .....	44-66
Pressure Line Fittings at Valve and Housing	
TRW Gear .....	10-15
Ford Built Gear .....	14-20
Valve Housing-to-Gear Bolts .....	12-15
Pinion Bearing Lock Nut .....	23-34
Pinion Bearing Plug .....	40-60
Rack Bushing Lock Nut .....	80-120
Tie Rod Ball Socket Lock Nut .....	25-35

ⓐ — Tighten to nearest cotter pin slot after tightening to specification.