

FORD NON-INTEGRAL BENDIX LINKAGE

Granada
Monarch
Versailles

DESCRIPTION

The Bendix Linkage non-integral power steering system is a hydraulically controlled linkage type steering system consisting of power cylinder, control valve, fluid lines, steering gear and pump.

OPERATION

The hydraulic pump is belt driven from engine crankshaft. Fluid from pump reservoir is pressurized within pump according to operating requirements and maximum pressure is controlled by pump pressure relief valve. After fluid has passed from pump to control valve and power cylinder, it returns to the reservoir.

LUBRICATION, TROUBLE SHOOTING & TESTING

See *Power Steering General Servicing* in this section.

ADJUSTMENT

CAUTION — If a 2 post hoist is used to raise vehicle, place adapters under front suspension lower arms. Do not allow adapters to contact steering linkage.

CONTROL VALVE CENTERING SPRING ADJUSTMENT

Raise vehicle and remove spring cap attaching screws and lock washers, then remove spring cap. Tighten adjusting nut snug (90-100 INCH lbs.), then loosen nut ¼ turn. **NOTE** — Make sure nut rotates ¼ turn (90°) on the threads of the bolt. Do not overtighten adjusting nut. Position spring cap to valve housing, install attaching screws and washers, and tighten. Lower vehicle.

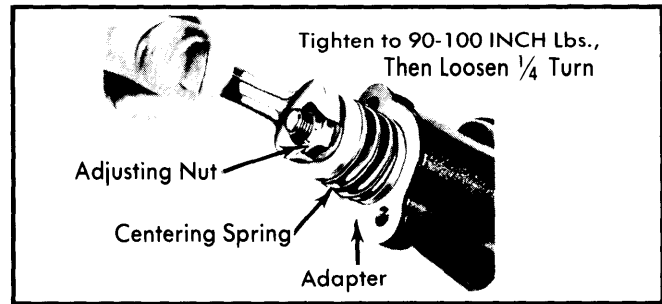

Fig. 1 Adjusting Centering Spring

REMOVAL & INSTALLATION

POWER STEERING CONTROL VALVE

Removal — Disconnect four fluid line fittings at control valve, drain fluid from lines. Turn wheels to left and right several times to force all fluid from system. Loosen clamping nut and bolt at right end of sleeve. Remove roll pin from steering arm-to-idler arm rod through the slot in the sleeve. Remove control valve ball stud nut. Using a suitable tool, remove ball stud from sector shaft arm. After turning front wheels fully to left, unthread control valve from center link steering arm-to-idler arm rod.

Installation — Thread valve onto center link until about four threads are still visible. Position ball stud in sector arm shaft. Measure distance between the center of left spindle connecting rod hole in center link to end of control valve. This distance must be 2.55" to 2.65". If distance is not correct, disconnect ball stud from sector shaft arm and turn valve on center link to increase or decrease distance. Align hole in steering arm-to-idler arm rod with slot near end of valve sleeve. Install roll pin in rod hole to lock valve into position. Tighten valve sleeve clamp bolt. Install nut on ball stud. Connect fluid lines to control valve. **CAUTION** — Do not overtighten. Fill fluid reservoir to cross hatched area on dip stick.

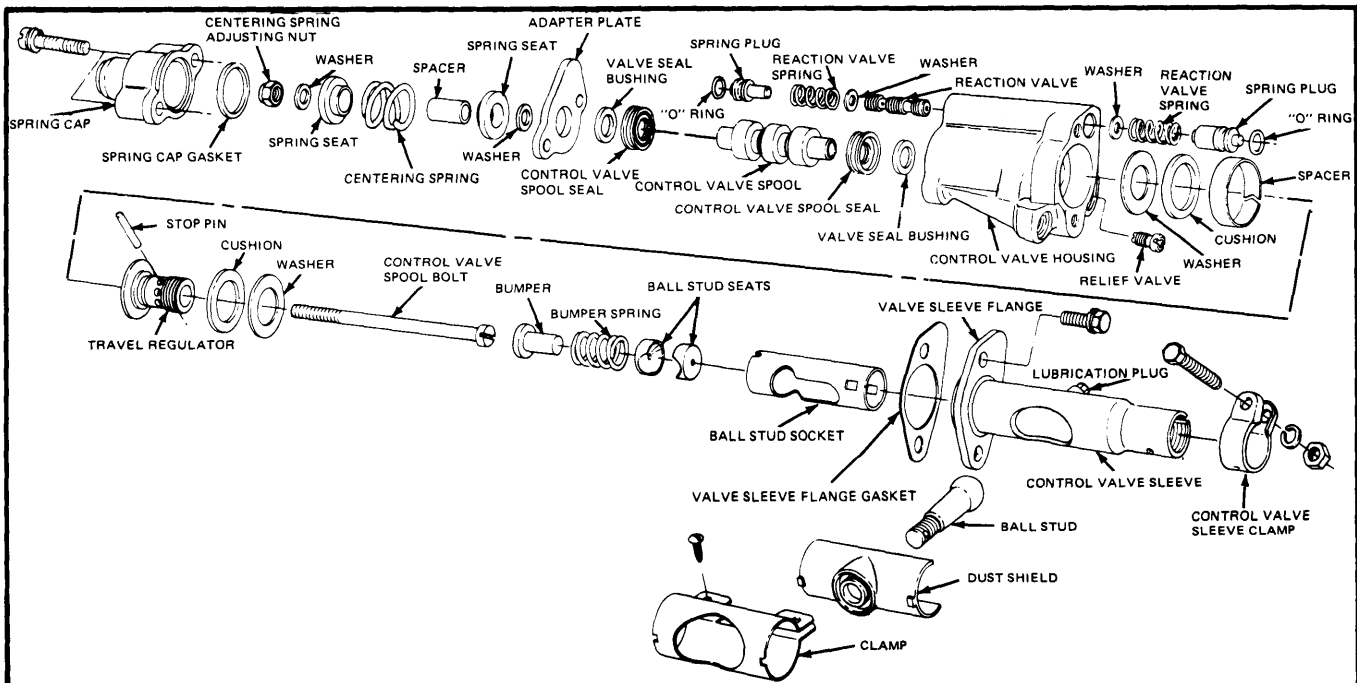

Fig. 2 Bendix Power Steering Control Valve Assembly

FORD NON-INTEGRAL BENDIX LINKAGE (Cont.)

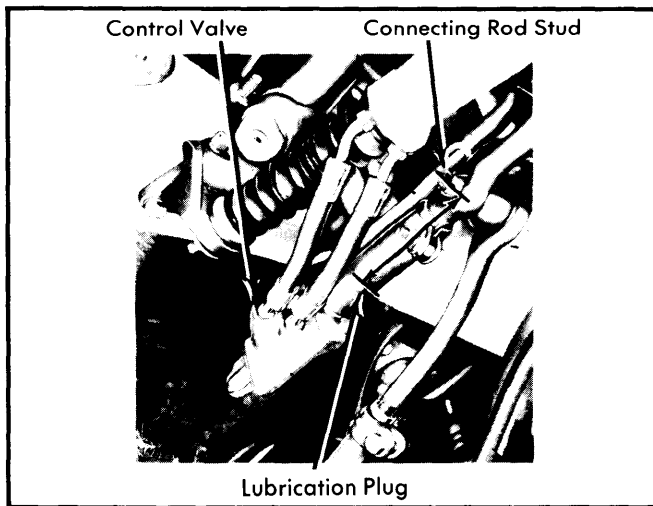

Fig. 3 Control Valve Installation Measurement

NOTE — With engine running, check position of steering wheel (front wheels in straight ahead position). Do not make any adjustments until toe-in is checked. If either toe-in or steering wheel position is not correct, make all adjustments at spindle connecting rod sleeves.

POWER CYLINDER

Removal — Disconnect power cylinder fluid lines and allow to drain into a container. Remove nuts and insulator from end of cylinder rod. Remove cotter pin and nut securing cylinder to center link. Use a suitable steering linkage ball stud pressing tool (T64P-3590-F) to press cylinder stud from center link.

CAUTION — A ball stud pressing tool must be used or damage to power cylinder may result.

Linkage must be lowered to install the removal tool. If control valve has not been removed from pitman arm, remove attaching bolts from idler arm and lower linkage to install tool and remove ball stud. Remove insulator sleeve and washer from power cylinder rod end. Remove boot and discard clamp. Reconnect idler arm bracket to side rail if disconnected and tighten to specified torque. Inspect tube fittings and seats in power cylinder for damage and replace seats or tubes as required.

Installation — Install cylinder rod boot with a new clamp. Install washer, sleeve, and insulator on end of power cylinder rod. Extend rod as far as possible. Insert rod in bracket on frame and compress rod as necessary to insert stud in center

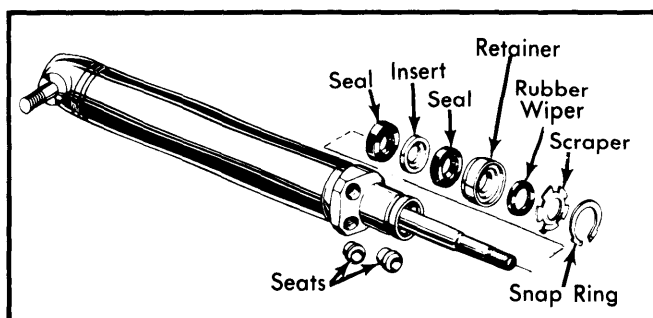

Fig. 4 Power Cylinder Assembly

link. Secure stud with a castellated nut and cotter pin. Secure power cylinder rod with an insulator, washer, nut and pal nut. Connect fluid lines into correct ports and position lines so they are parallel to each other. Fill reservoir with suitable fluid (D2AZ-19582-A), start engine and turn wheels to right and left positions several times, then recheck fluid level in pump and add as required. Examine system for leaks during full turning loads.

CONTROL VALVE-TO-POWER CYLINDER HOSES

Removal — Raise vehicle and disconnect hoses from power cylinder and allow fluid to drain. Disconnect hoses from control valve and remove hoses.

Installation — Connect unmarked end of shorter hose to control valve. Connect other hose to control valve and hold hose so bend is parallel to surface of valve. Hold hoses from turning while tightening fittings as required. Connect opposite end of short hose to lower port in power cylinder and connect longer hose to upper port in cylinder. Ensure that hoses do not twist and remain parallel after tightening fittings. Fill pump reservoir with power steering fluid. Check system for correct operation and fluid leaks.

POWER STEERING PUMP-TO-CONTROL VALVE HOSES

Removal — Remove reservoir fluid and raise vehicle. Disconnect hoses at control valve and drain fluid. Lower vehicle and disconnect fluid hoses at pump. Remove bolts and clips attaching hoses, insulator, and retainer as an assembly.

Installation — Install both hoses in insulator and retainer. The paint stripe on pressure hose must align with slot on insulator. The paint or tape band on return hoses must center in insulator. Position the assembly at the original location and install attaching bolts. Place a hose clamp on return line and install on reservoir fitting. Connect pressure hose to outlet fitting and tighten as required. Raise vehicle and connect hose fittings to control valve, finger tight. Install clamp on hoses and tighten screw. Now tighten hose fittings as required. Fill pump reservoir with power steering fluid and check system for correct operation and fluid leaks.

POWER CYLINDER SEAL

Removal — Clamp cylinder in vise, remove snap ring from end of cylinder. **CAUTION** — Do not clamp cylinder with excessive force. Pull piston rod out to remove scraper, bushing and seals. If seals cannot be removed in this manner, remove them with an ice pick. **CAUTION** — Avoid damage to shaft or seal.

Installation — Coat new seals and shaft with a suitable lubricant. Push rod in cylinder and install parts in cylinder with a deep socket slightly smaller than the cylinder opening.

OVERHAUL

CONTROL VALVE

Disassembly — 1) Clean outside of valve before disassembly. **NOTE** — Clamp valve in a soft jaw vise at sleeve flange to prevent damage. Remove centering spring cap from valve housing.

Power Steering

FORD NON-INTEGRAL BENDIX LINKAGE (Cont.)

2) Remove nut from end of valve spool bolt. Remove washers, spring seats, spacer, centering spring, adapter and bushing from bolt and valve housing. Remove bolts holding valve housing and sleeve together; separate housing from sleeve.

3) Push spool toward spring cap end of housing, remove seal and bushing, then push spool to sleeve end, forcing out spacer, cushion, and washer. Remove control valve spool.

NOTE — Observe direction spool is removed from valve housing as it must be reassembled in same direction. Remove four hose seats from control valve housing.

4) Remove spring plug, "O" ring, washer, and spring from actuator end of control valve housing. Invert valve housing and repeat above procedure. Remove reaction limiting valve.

5) Remove gasket from housing end of control valve sleeve. Remove dust shield and inspect for damage in spring area. Tilt ball stud toward clamp end of sleeve. Pull control valve spool valve out as far as possible; stop pin will fall out or can be pushed out easily.

6) Unscrew travel regulator and lay regulator and control valve spool bolt aside. Slide ball stud toward clamp end as far as possible to move ball stud socket to that end of valve sleeve. Remove ball stud by moving it toward housing end and pulling straight out. Remove ball stud socket, bumper, spring, and two ball stud seats.

Reassembly — 1) Coat all parts except seals with power steering lubricant; coat seals with suitable lubricant (COAZ-19553-A). Install reaction valve, two washers, two springs, two spring plugs and "O" ring assembly. Insert one ball stud seat (flat end first) into ball stud socket and insert into control valve sleeve as far as possible with threaded end toward outside. Insert ball stud through openings in valve sleeve and ball stud socket. Pull stud out and hold it on socket at ball stud opening. Insert remaining seat, round side in; install bumper and bumper spring. Assemble regulator and spool bolt. Install cushion and washer onto regulator and thread regulator into ball stud socket. Using proper wrench on regulator flats, torque travel regulator to 5-10 ft. lbs., then loosen until nearest hole is aligned with slots (at least 1/2 hole, but no more than 1 1/2 holes). Insert pin and tilt ball stud toward housing end to retain pin. Lay unit aside.

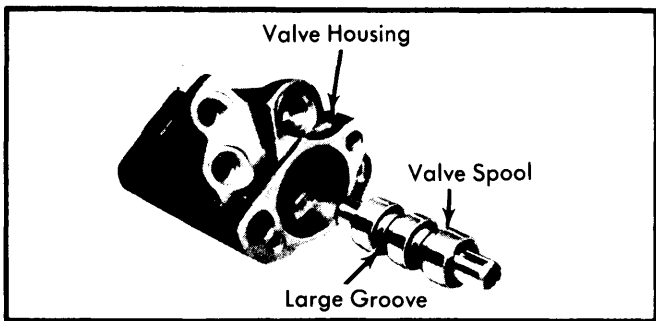

Fig. 5 Valve Spool Installation

2) Install spool seal, seal bushing, washer, spacer, and cushion into sleeve end of housing; and place on a flat surface. Carefully rotate spool into housing with groove nearest cap end (see illustration) until contact with spool seal is felt. Pick up housing and press on cushion at sleeve end while rotating

spool through seal. Position spool so it just protrudes through seal bushing and install seal over spool at cap end. Place sleeve on a flat surface and use a screwdriver to work seal into housing. Install the seal bushing.

3) Install gasket on sleeve assembly and attach to housing. Move ball stud laterally to see if it moves freely for about .20". Assemble washer, spacer, adapter, spring seat, control valve centering spring, spring seat, washer, and control valve spool nut; tighten nut to 90-100 INCH lbs., then loosen nut with respect to spool bolt 1/4 turn. Ball stud socket will turn first, the 1/4 turn applies after stud hits sleeve window and spool bolt has turned to its stop.

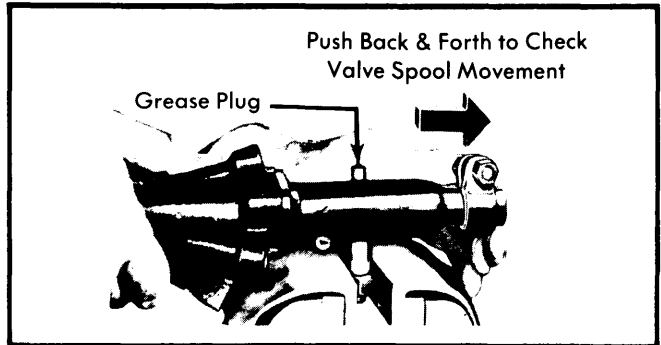

Fig. 6 Checking Valve Spool Movement

4) While holding adapter plate to housing, move stud back and forth to check freedom of valve spool travel (see illustration). Install control valve spring cap and spring cap gasket on adapter plate and tighten screws as required. Install boot and clamp over stud. Ensure that boot garter spring is attached. Loosely install screws. Move stud sideways to determine center position and hold there. Place clamp against grease fitting and tighten screws. Remove grease plug and grease with .35-.55 ounces of suitable grease (ESA-M1C75-A).

TIGHTENING SPECIFICATIONS

Application	Ft. Lbs.
Control Valve Sleeve Clamp Nut	13-17
Hoses-to-Control Valve	
Return Hose Fitting (5/8" Hex)	16-25
Pressure Hose Fitting (1/2" Hex)	15-19
Hoses-to-Power Cylinder	15-19
Hoses-to-Pump	
Female Fitting (1 3/16" Hex)	16-25
Male Fitting (5/8" Hex)	16-25
Spring Cap Screws	6-8
Hose Clamp Screw	12-36 INCH Lbs.
Power Cylinder Mounting Nut	18-24
Power Cylinder Pal Nut	3-5
Pitman Arm-to-Control Valve	⓪43-47
Steering Gear-to-Frame	60-65
Pitman Arm-to-Sector Shaft	
Granada, Monarch, Versailles	200-225
All Others	236-250

⓪ — Torque to lower specification, then tighten to nearest cotter pin slot.