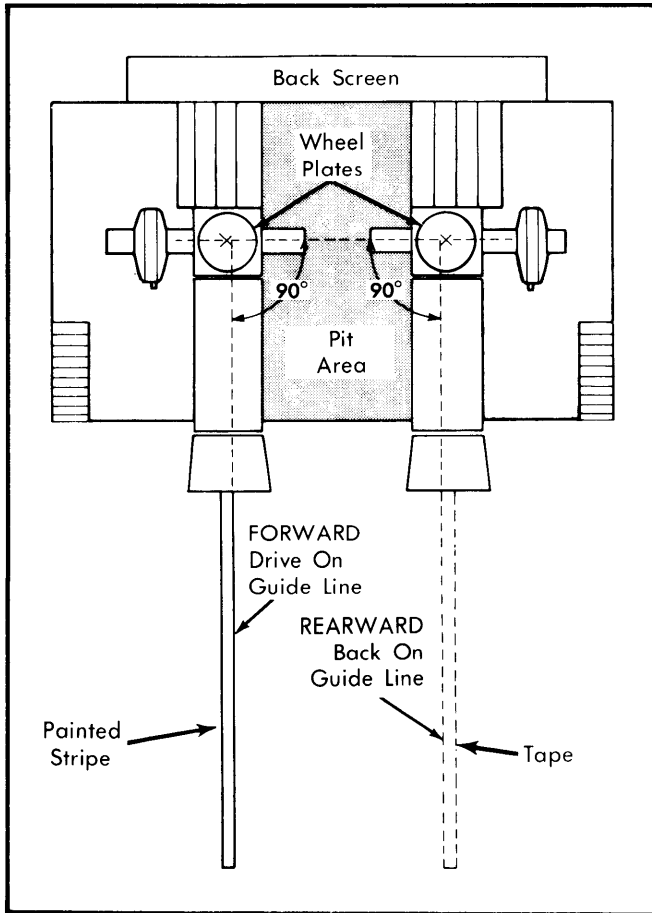
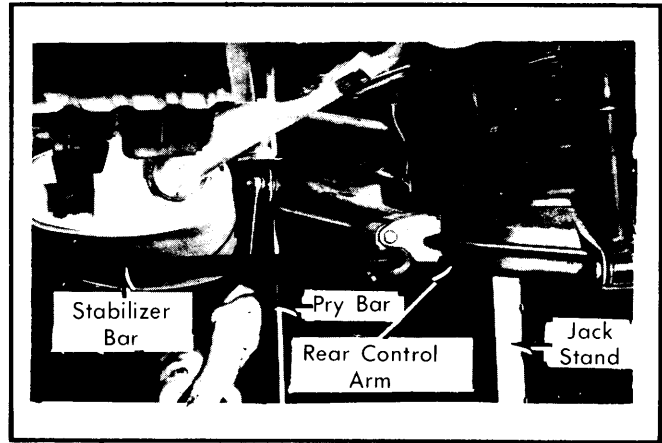


# Wheel Alignment

## GENERAL MOTORS (Cont.)



**Fig. 16 Typical Alignment Machine Set Up For Eldorado Rear Wheel Alignment**



**Fig. 17 Adjusting Rear Wheel Alignment (Eldorado)**

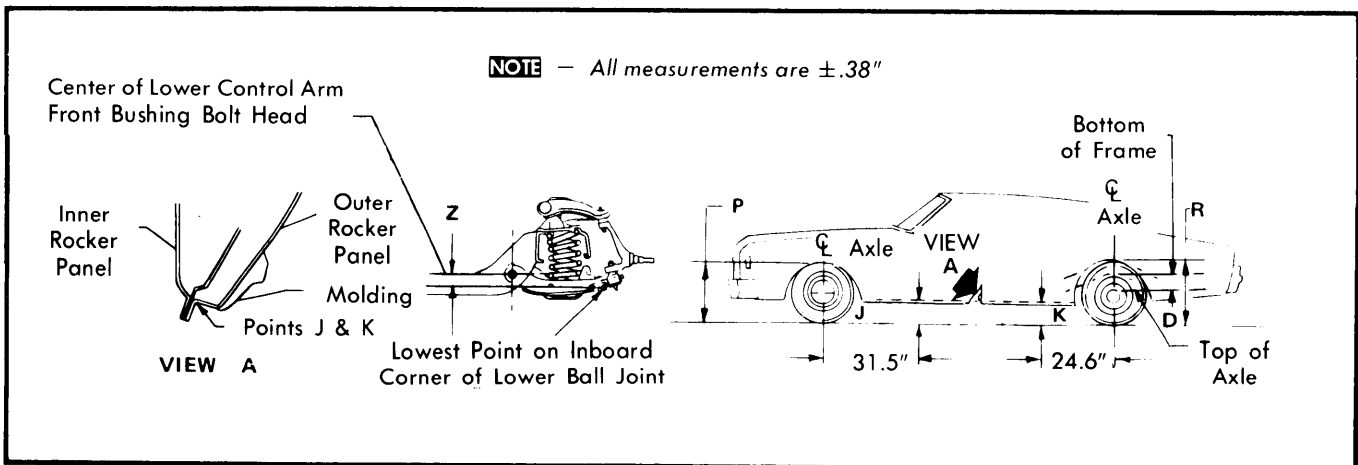
## CHEVROLET

### TIRE INFLATION (COLD)

Inflate tires to manufacturer's specifications, found on tire inflation placard attached to left front door.

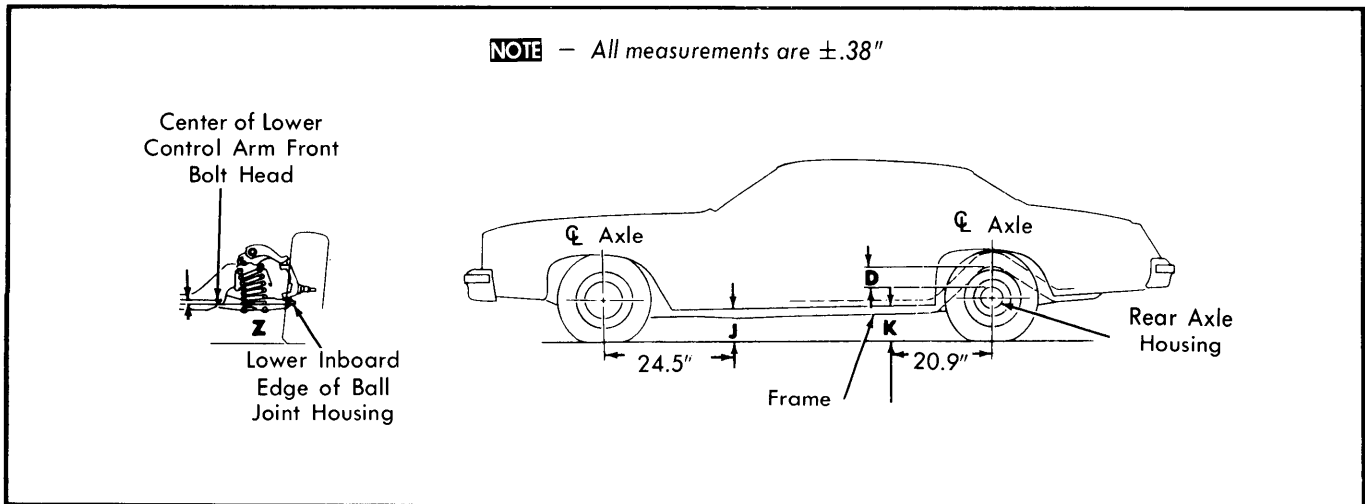
### RIDING HEIGHT

With car on smooth level floor, lift car about 1 1/2" at front bumper and allow vehicle to settle on its own. Repeat twice more, then measure the "Z" and "J" height in the settled position after third lift. Repeat procedure and average the readings for true measurement. When measuring "D" and "K" height, follow same procedure except lift and push on rear bumper. Measurements must be within specifications. See RIDING HEIGHT SPECIFICATIONS and Figs. 18 through 24.

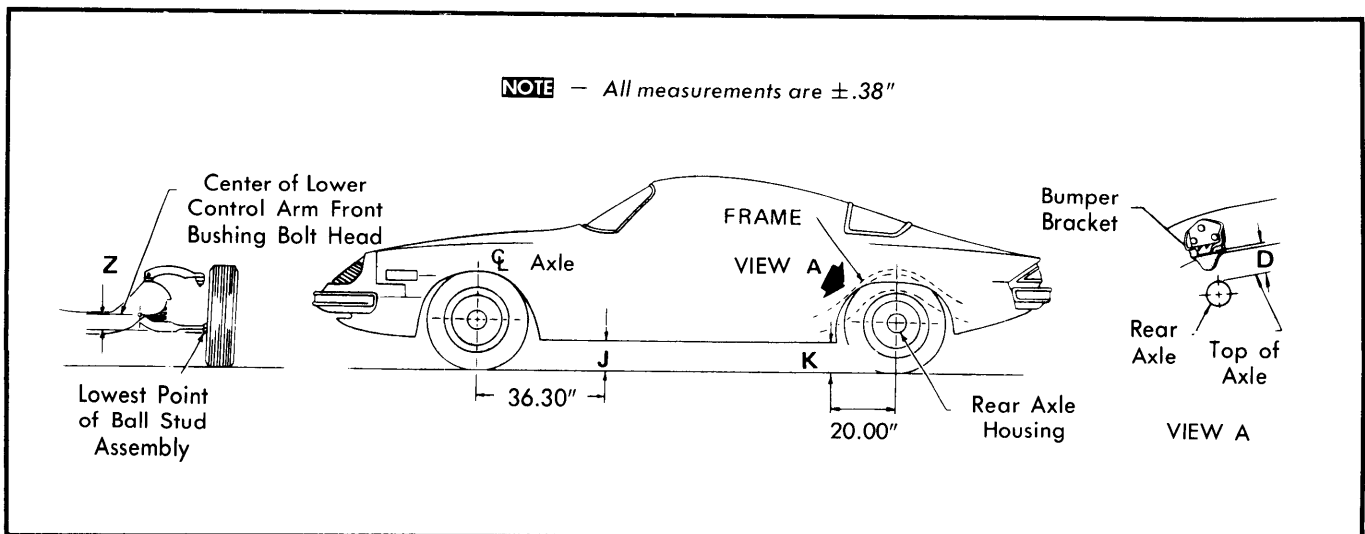


**Fig. 18 Riding Height Measuring Points (Caprice & Impala)**

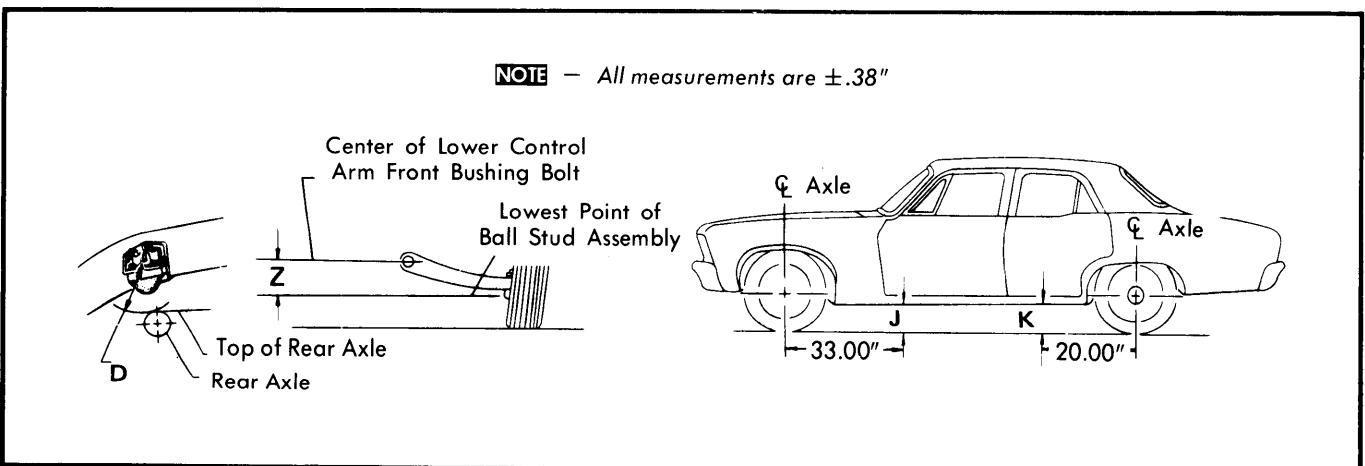
## GENERAL MOTORS (Cont.)



**Fig. 19 Riding Height Measuring Points (Monte Carlo, Malibu, El Camino & Caballero)**



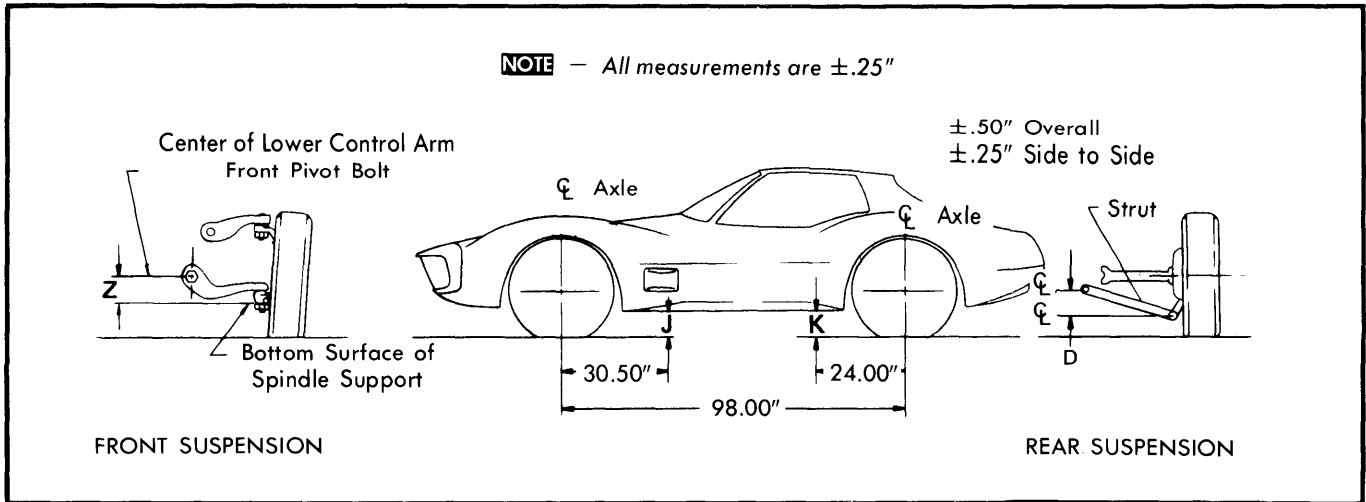
**Fig. 20 Riding Height Measuring Points (Camaro & Berlinetta)**



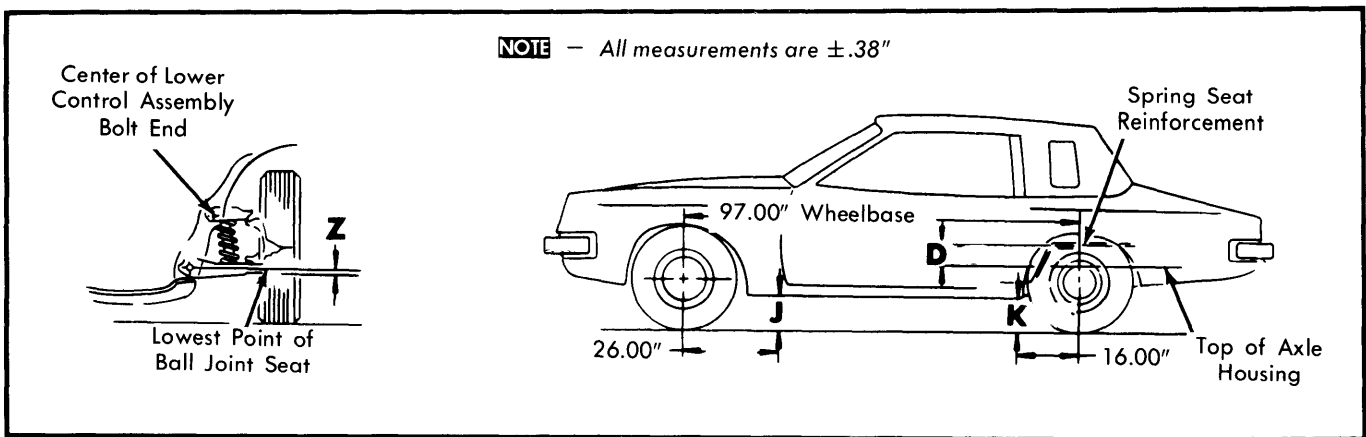
**Fig. 21 Riding Height Measuring Points (Nova)**

# Wheel Alignment

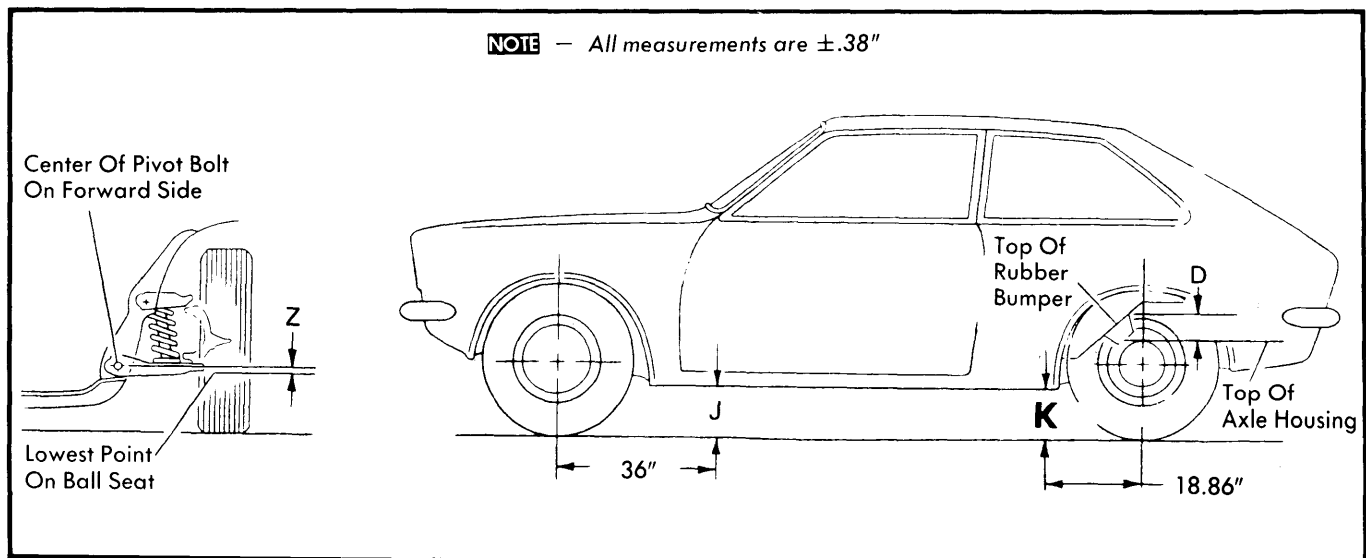
## GENERAL MOTORS (Cont.)



**Fig. 22 Riding Height Measuring Points (Corvette)**



**Fig. 23 Riding Height Measuring Points (Monza)**



**Fig. 24 Riding Height Measuring Points (Chevette)**

## GENERAL MOTORS (Cont.)

### RIDING HEIGHT SPECIFICATIONS

**NOTE** — To obtain readings "Z" and "J", raise front bumper about 1 1/2" and let loose. Repeat three times. Take measurements. Repeat procedure pushing bumper down 1 1/2" three times and releasing. Take measurements. Average the two measurements. Follow a similar procedure to obtain measurements "D" and "K" only lift and lower rear bumper.

Application	Tires	Z	J	K	D	
Caprice & Impala <sup>①</sup>	FR78-15	2.68"	10.51"	10.63"	6.38"	
	GR78-15	2.32"	10.51"	10.63"	6.02"	
	GR70-15	2.32"	10.51"	10.63"	6.02"	
	HR78-15	2.21"	10.55"	10.66"	5.04"	
Malibu Sedan & Coupe	P185-75R14	2.60"	9.96"	10.27"	5.63"	
	P195-75R14	2.32"	9.96"	10.27"	5.39"	
	P205-75R14	2.01"	9.96"	10.27"	6.61"	
	P205-70R14	2.44"	9.96"	10.28"	5.47"	
Sedan & Coupe (Perf. Susp.)	P205-70R14	2.28"	9.96"	10.27"	5.39"	
Wagon	P195-75R14	2.28"	9.96"	10.27"	5.39"	
Monte Carlo	P205-70R14	2.36"	9.72"	9.68"	4.76"	
El Camino & Caballero	P205-75R14	2.05"	9.92"	10.31"	5.00"	
El Camino & Caballero (Perf. Susp.)	P205-75R14	2.05"	9.92"	10.31"	5.00"	
Camaro & Berlinetta	E78-14	1.74"	8.20"	7.85"	5.00"	
	FR78-14	2.00"	8.20"	7.85"	4.47"	
	GR70-15	1.42"	8.20"	7.85"	4.08"	
	P225-70R15	1.44"	8.20"	7.85"	4.08"	
Nova	E78-14	1.48"	9.71"	9.69"	5.61"	
	FR78-14	1.79"	9.71"	9.69"	5.84"	
Monza Coupe & Hatchback 4-Cylinder	A78-13	2.28"	7.75"	7.75"	10.16"	
	B78-13	2.13"	7.75"	7.75"	10.03"	
	BR78-13	2.42"	7.75"	7.75"	10.29"	
	BR70-13	2.24"	7.75"	7.75"	10.12"	
	V6 & V8	B78-13	2.18"	7.75"	7.75"	10.03"
		BR78-13	2.53"	7.75"	7.75"	10.29"
		BR70-13	2.32"	7.75"	7.75"	10.09"
	Wagon 4-Cylinder	B78-13	2.37"	7.75"	7.75"	10.30"
		BR78-13	2.09"	7.75"	7.75"	10.04"
		BR70-13	2.20"	7.75"	7.75"	10.13"
V6		B78-13	2.13"	7.75"	7.75"	10.04"
	BR78-13	2.43"	7.75"	7.75"	10.31"	
	BR70-13	2.19"	7.75"	7.75"	10.09"	
Corvette	P225-70R15	2.79"	8.68"	8.57"	2.22"	
	P225-60R15	3.02"	8.68"	8.57"	2.40"	
Chevette Coupe	P155-80R13	2.36"	9.02"	8.86"	5.43"	
	Sedan	P155-80R13	2.36"	9.02"	8.86"	5.43"

① — Reading "P" should be 29.06" and "R" should be 28.82" for HR78-15 (Wagons) and 29.21" for other models.

# Wheel Alignment

## GENERAL MOTORS (Cont.)

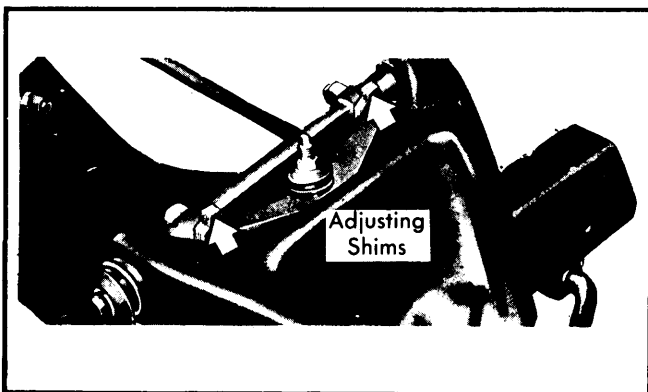
### CAMBER

**All Models (Exc. Monza and Chevette)** — Loosen bolts and nuts attaching upper control arm shaft to frame. Adding an equal number of shims at both front and rear bolts will decrease positive camber, while subtracting an equal number of shims will increase camber. Tighten bolts when adjustment is completed. See Figs. 25 and 26.

**NOTE** — Normal shim pack will leave at least 2 threads of bolt exposed beyond nut. Also, difference between front and rear shim packs must not exceed .40".

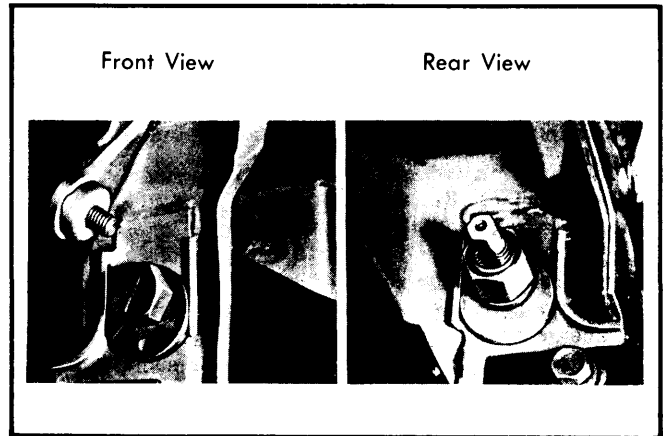


**Fig. 25 Caster and Camber Adjusting Shims (Exc. Corvette, Monza and Chevette)**



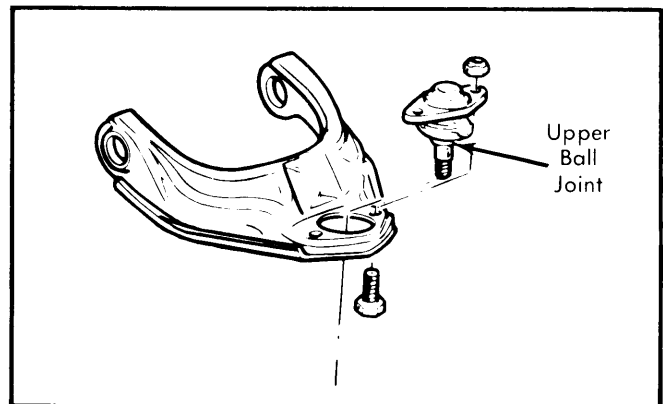
**Fig. 26 Caster and Camber Adjusting Shims (Corvette)**

**Monza** — To adjust camber, loosen front lower control arm pivot nut and rotate cam until proper setting is obtained. Eccentric cam action will move lower control arm in or out. Hold cam bolt stationary and tighten nut. See Fig. 27.



**Fig. 27 Caster and Camber Adjustment (Monza)**

**Chevette** — Remove upper ball joint, rotate one half turn and reinstall with flat surface of upper flange facing inboard side of the control arm. This will increase camber angle approximately 1°. See Fig. 28.



**Fig. 28 Chevette Camber Adjustment**

### CASTER

**All Models (Exc. Monza and Chevette)** — Loosen bolts and nuts attaching upper control arm shaft to frame. To decrease caster, add shims to front bolts and remove shims from rear bolt. To increase caster, remove shims from front bolt and add shims to rear bolt. Tighten attaching bolts when adjustment is completed. See Figs. 25 and 26.

**NOTE** — Normal shim pack will leave at least two threads of bolt exposed beyond nut. Difference between front and rear shim packs must not exceed .40".

**Monza** — To adjust, loosen rear lower control arm pivot nut and rotate cam until proper setting is obtained. Cam will move lower control arm forward or rearward. Hold cam bolt stationary and tighten nut. Recheck camber after setting caster. See Fig. 27.

## GENERAL MOTORS (Cont.)

**Chevette** — Adjust caster by realigning washers located between legs of upper control arm. See Fig. 29.

**NOTE** — Always use 2 washers with a combined thickness of .472". If a .12" washer is installed at front and .35" washer at rear it will change caster +1°. If reversed with .35" washer at front and .12" washer at rear it will change caster by -1°.

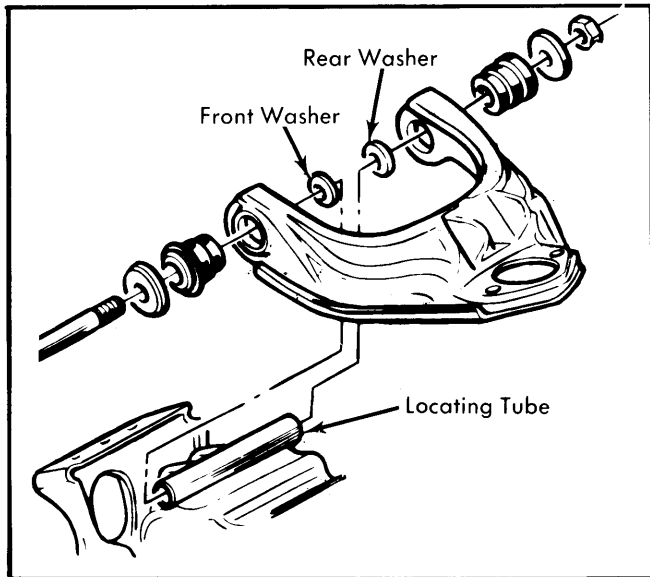


Fig. 29 Chevette Caster Adjustment

### REAR WHEEL ALIGNMENT (CORVETTE ONLY)

**Camber** — 1) Back vehicle onto alignment machine. See CADILLAC (Eldorado), Fig. 16. Camber adjustments are made by adjusting eccentric cam and bolt assembly located at in-board mounting of strut rod.

2) To change camber setting, loosen lock nut on cam bolt and rotate cam and bolt assembly until specified camber is obtained.

**Toe-In** — 1) To adjust rear wheel toe-in angle, add various thicknesses of shims inside the frame side member on both sides of torque control arm pivot bushing.

**NOTE** — When vehicle is backed onto alignment machine, toe-in will be read as toe-out and toe-out will be read as toe-in.

2) Shims are slotted to slide over bushing pivot bolt on either side. To adjust, loosen pivot bolt, remove cotter pin retaining shims, and remove shims. Position torque control arm to obtain specified toe-in. Shim the gap toward vehicle centerline between torque control arm bushing and frame side inner wall. See Fig. 30.

**NOTE** — Do not use thicker shims than necessary. Do not use excessive force when shimming or toe-in setting may change.

3) Shim outboard gap as necessary to obtain solid stack-up between control arm and inner wall of frame side member. Then install cotter pin (loop outboard) through the shims. See Fig. 30. Tighten pivot bolt to 50 ft. lbs.

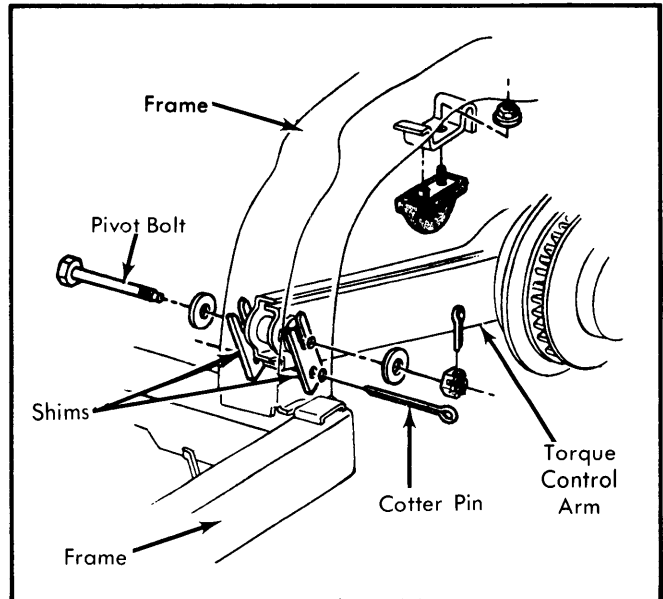


Fig. 30 Rear Suspension Toe-in Shims (Corvette)

## OLDSMOBILE

### TIRE INFLATION (COLD)

Inflate tires to recommended pressures listed on rear of left front door on Omega and Starfire models, and inside glove box door on all other models.

### RIDING HEIGHT

**All Models (Exc. Toronado)** — Check riding height with full gas tank, front seat rearward, tire pressure correct, doors closed and trunk empty. With vehicle on level floor, bounce several times and allow car to settle. Measure heights as shown in Fig. 31. Measured heights may differ side to side by  $\pm 3/4$ ".

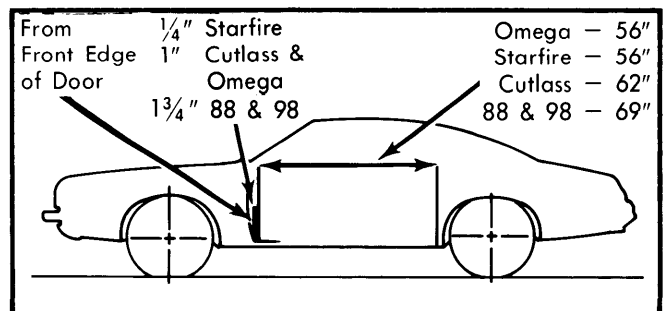


Fig. 31 Riding Height Measuring Points (Oldsmobile Except Toronado)

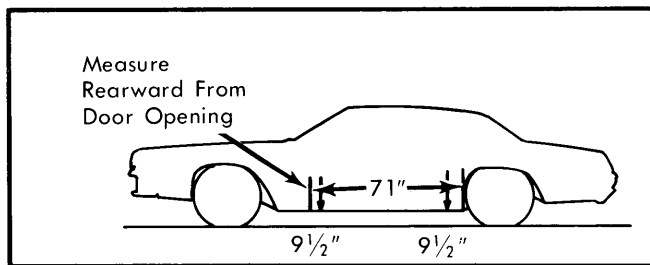
# Wheel Alignment

## GENERAL MOTORS (Cont.)

**Tornado** – 1) Check riding height with full gas tank, front seat rearward, tire pressure correct, doors closed and trunk empty. With vehicle on level floor, bounce several times and allow car to settle.

2) Measure heights from bottom of rocker molding to floor at points indicated in Fig. 32. Measured heights may differ side-to-side or front-to-rear by  $\pm 3/4$ ".

3) To adjust front riding height, raise car at front crossmember to relieve strain on torsion bar adjusting bolt. Lubricate adjusting bolt before attempting to change riding height. Turn clockwise to increase counterclockwise to decrease front riding height.



**Fig. 32 Riding Height Measuring Points (Oldsmobile Tornado)**

### RIDING HEIGHT SPECIFICATIONS

Application	Front	Rear
Starfire .....	7.75"	7.75"
Omega .....	9.62"	9.50"
Cutlass (Exc. Wagon) ....	9.75"	9.75"
Cutlass Wagon .....	9.62"	9.62"
88 & 98 .....	9.87"	9.87"
Tornado .....	9.50"	9.50"

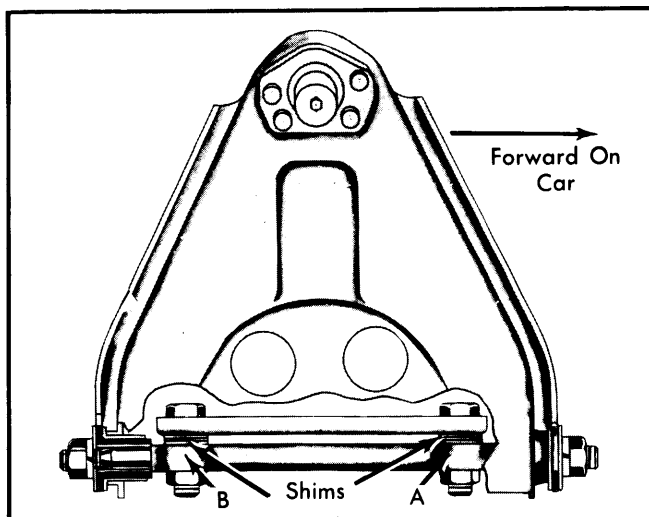
### CASTER

**All Models (Exc. Starfire and Tornado)** – 1) Loosen pivot shaft-to-frame nuts. See Fig. 33.

**NOTE** – Bolts are splined to frame and should not be turned. Loosen only the nuts. Do not remove weight of vehicle from front wheels.

2) To decrease positive caster (increase negative caster), add shims at front bolt. To increase positive caster (decrease negative caster), remove shims at front bolts.

**Starfire** – Always adjust camber before adjusting caster. To adjust caster, loosen rear lower control arm pivot nut and rotate cam until specified caster setting is obtained. Cam action moves lower control arm forward or rearward. Tighten pivot nut and recheck caster setting. See Fig. 27 in CHEVROLET section for illustration of cams.



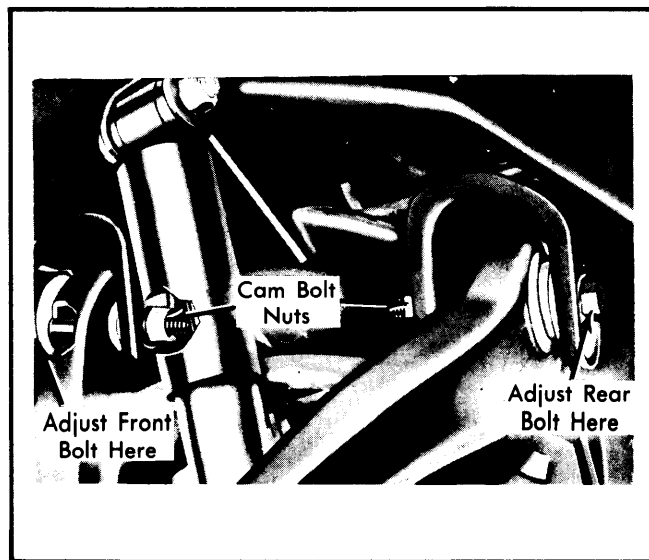
To Decrease Positive Caster: Add Shim At "A"  
 To Decrease Negative Caster: Remove Shim At "A"  
 To Increase Camber: Remove Shims At Both "A" And "B"  
 To Decrease Camber: Add Shims At Both "A" And "B"

**Fig. 33 Adjusting Shims for Caster and Camber (All Models, Exc. Starfire and Tornado)**

**Tornado** – 1) Note camber reading before adjusting caster. Hold front cam bolt and loosen nut. Turn cam to obtain a change equal to  $1/4$  of the desired caster change. See Fig. 34.

**NOTE** – At front cam bolt, a positive camber change produces a positive caster change, and a negative camber change produces a negative caster change.

2) Hold cam bolt in position while tightening nut to 110 ft. lbs. Then hold rear cam bolt and loosen nut. Turn cam bolt to return CAMBER to its original setting. Hold cam bolt and tighten nut to 110 ft. lbs. Recheck both camber and caster settings.



**Fig. 34 Caster & Camber Adjusting Cams (Tornado)**