

## DELCO-MORAINE AUTOMATIC ADJUSTER

**Buick**  
**Cadillac (W/O Rear Disc Opt.)**  
**Chevrolet (Exc. Corvette & Chevette)**  
**Oldsmobile**  
**Pontiac**

### DESCRIPTION

Brakes are hydraulic single anchor and use Bendix type shoes. Anchor pins for brake shoes are fixed to backing plate and are non-adjustable. Automatic system is made up of a link, actuating lever, pawl and pawl spring. Pawl spring is mounted on secondary brake shoe. System uses an override pivot plate and spring to protect against binding linkage. **NOTE** — Some models use an adjuster pawl with a separate blade to contact star wheel. This system does not use the override spring.

### OPERATION

Automatic adjusters operate only when brakes are applied as car is moving in reverse. The link, which holds top of actuating lever stationary, forces lever to pivot on secondary shoe. This pivoting action forces pawl downward against tooth on adjuster screw. If the lining-to-drum clearance is correct, the downward movement will stop before adjusting screw is turned. If clearance is too wide, secondary shoe will move outward. This allows pawl to move down enough to turn adjuster screw one notch. This brings lining-to-drum clearance back to correct specifications. If adjuster screw is frozen or clearance is too great, an override device will prevent adjuster movement. This will prevent binding of automatic adjuster linkage.

### ADJUSTMENT

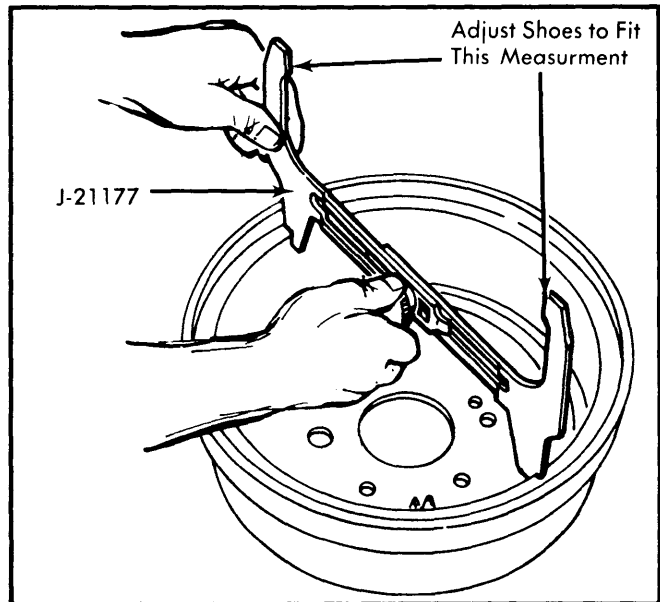
#### BRAKE SHOE ADJUSTMENT

Adjustment should be required only after relining or replacing shoes, or if length of adjusting screw is changed.

**Buick** — Remove adjusting hole cover. Install a tool through hole to move self-adjuster lever off of adjusting screw. Use adjusting tool to turn adjusting screw and expand brakes. Expand brakes until wheel can just be turned by hand. Make sure drag is equal on both wheels. Back off adjusting screw 30

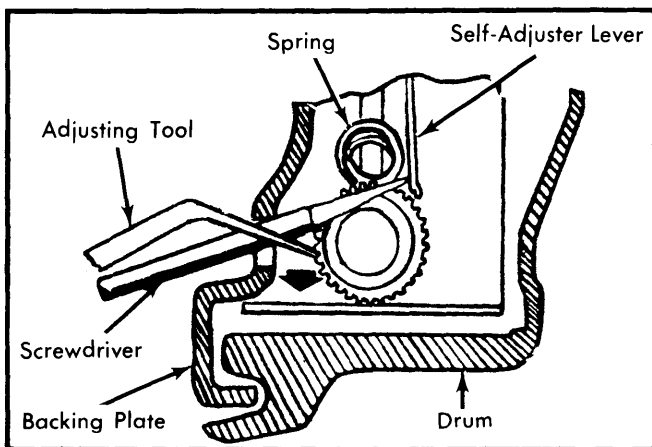
notches. If shoes still drag, back screw off one or two more notches. Brakes should not drag after 12 notches. If heavy drag is felt, check for a tight parking brake cable.

**Cadillac, Oldsmobile & Pontiac** — Remove wheels and drums. Make sure parking brake cable and linkage is free. Measure drum inside diameter using a suitable tool (J-21177). Adjust shoes to fit opposite side of measuring tool. See Fig. 2. Install drums and wheels. Drive vehicle alternately backward and forward, applying brakes moderately until pedal travel is adequate (approximately  $2\frac{1}{16}$ ").

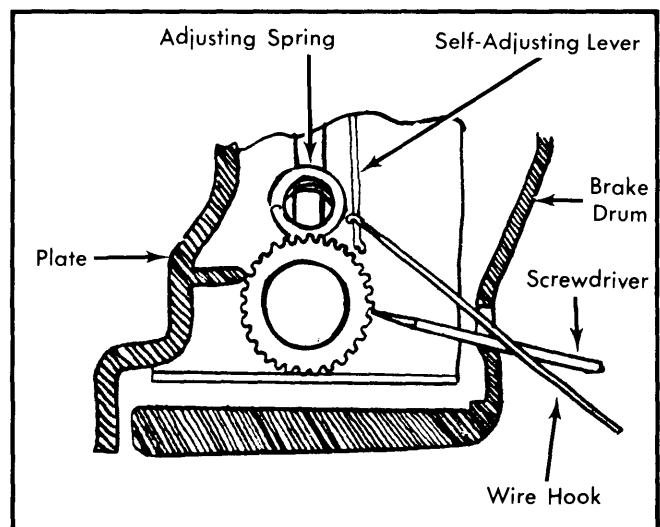


**Fig. 2 Measuring Drum Inside Diameter for Brake Shoe Clearance**

**Chevrolet** — Use the same adjustment procedure as described in Buick brake shoe adjustment.



**Fig. 1 Adjusting Brake Shoe Clearance (Through Backing Plate)**



**Fig. 3 Adjusting Brake Shoe Clearance (Through Drum)**

# Brake Systems

## DELCO-MORAINE AUTOMATIC ADJUSTER (Cont.)

### PARKING BRAKE ADJUSTMENT

**Buick** — 1) On Skyhawk models, apply parking brake one notch then raise and support vehicle. Remove propeller shaft to gain access to equalizer lock nut. Loosen equalizer lock nut and tighten adjusting nut until a light drag is felt when rear wheels are rotated. Tighten lock nut. With parking brake fully released, no drag should be felt while rotating rear wheels.

2) On all other models, apply parking brake two notches then raise and support vehicle. Tighten adjusting nut until left rear wheel can just be turned rearward but locks up when turned forward. With parking brake released, wheels should turn freely in both directions.

**Cadillac** — Lubricate parking brake linkage at equalizer and cable stud, and ensure free movement of cables. Depress parking brake pedal to approximately 1½" from fully released position. Raise rear wheels. Hold brake cable stud from turning, and tighten equalizer nut, one turn at a time (checking for brake drag after each turn), until light drag is felt on either wheel (turning forward). Release parking brake. No drag should be present at either wheel. After adjustment, parking brake pedal should travel 5.25-6.75" with a pedal force of 125 lbs.

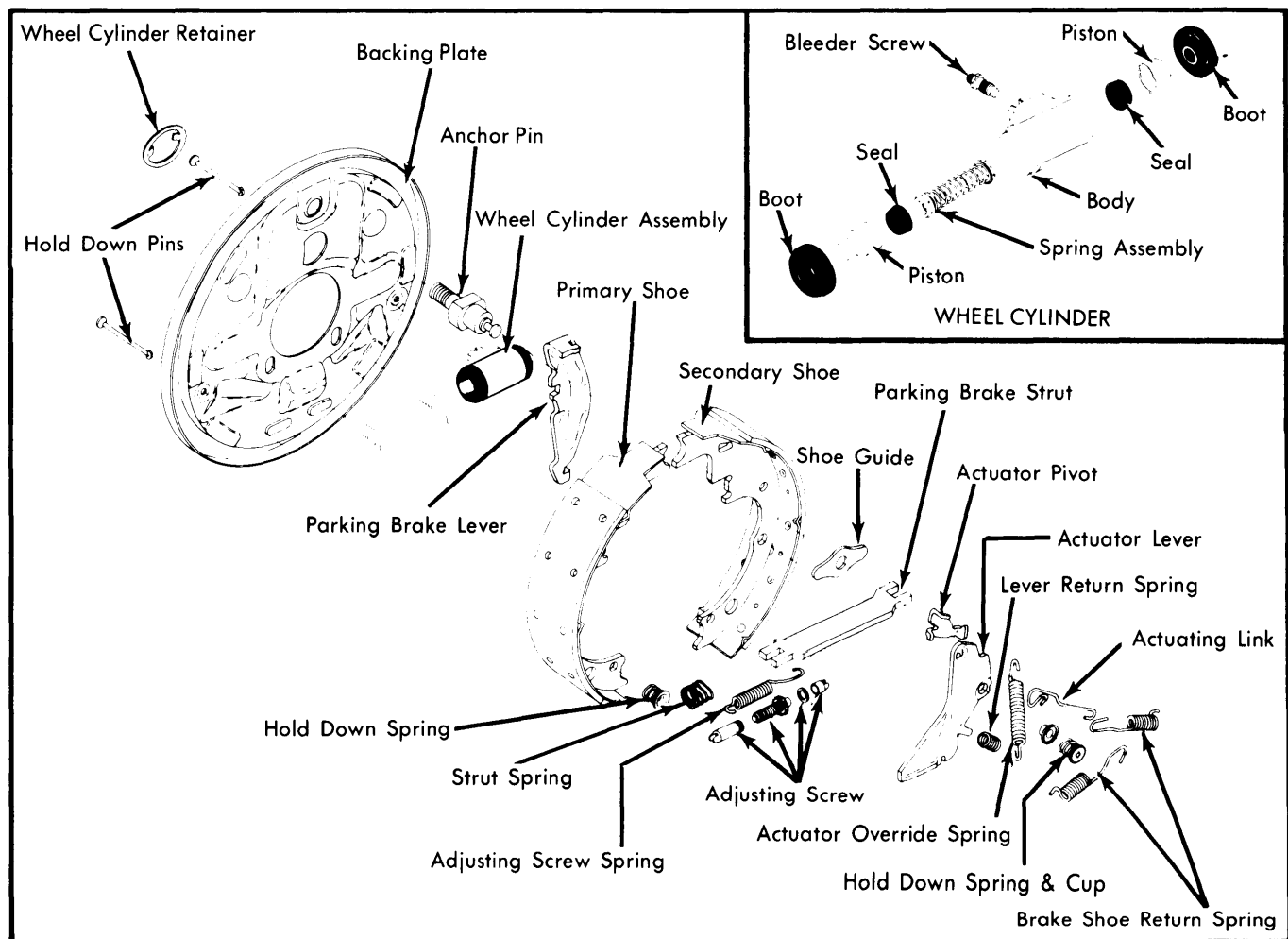
**Chevrolet** — 1) Apply parking brake one notch on Monza, Impala and Caprice models or two notches on all other models. Raise and support vehicle. On Monza models, it is necessary to remove propeller shaft to gain access to equalizer lock nut. Loosen lock nut. Loosen lock nut.

2) On Monza models, tighten adjusting nut until a light drag is felt when rotating rear wheels. On all other models, tighten adjusting nut until left rear wheel can just be turned rearward and locks up when turned forward.

3) With parking brake fully released, no drag should be felt at rear wheels. Install propeller shaft on Monza models.

**Oldsmobile** — 1) On Starfire models, apply parking brake one notch, then raise and support vehicle. Remove propeller shaft to gain access to equalizer lock nut. Loosen lock nut then tighten adjusting nut until a slight drag is felt while rotating rear wheels. With parking brake fully released, no drag should be felt when rotating rear wheels. Tighten lock nut and replace propeller shaft.

2) On all other models, apply parking brake two notches. Raise and support vehicle. Tighten adjusting nut until left rear wheel can just be rotated rearward but locks up when rotated forward. With parking brake fully released, no drag should be felt.



**Fig. 4 Exploded View of Rear Drum Brake Assembly & Wheel Assembly (Century, Malibu, Monte Carlo, El Camino, LeMans, Grand Prix & Cutlass)**

## DELCO-MORAINE AUTOMATIC ADJUSTER (Cont.)

**Pontiac** — 1) On Sunbird models, apply parking brake one notch. Raise and support vehicle. Remove propeller shaft to gain access to equalizer lock nut. Loosen lock nut, then tighten adjusting nut until a slight drag is felt while rotating rear wheels. With parking brake fully released, no drag should be felt when rotating rear wheels. Tighten lock nut and replace propeller shaft.

2) On Bonneville, Catalina, Firebird, and Phoenix models, apply parking brake two notches. Raise and support vehicle. Tighten adjusting nut until left rear wheel can just be rotated rearward but locks up when rotated forward. With parking brake fully released, no drag should be felt.

3) On LeMans and Grand Prix models, apply parking brake three notches. Raise and support vehicle. Tighten adjusting nut until left rear wheel can just be rotated rearward but locks up when rotated forward. With parking brake fully released, no drag should be felt.

### SHOE & LINING REPLACEMENT

**Removal** — **NOTE** — Mark position of springs and star adjusters as they are removed, for reinstallation in original position. Loosen parking brake cable at equalizer. If necessary, back off brake adjustment before removing drum. Unhook

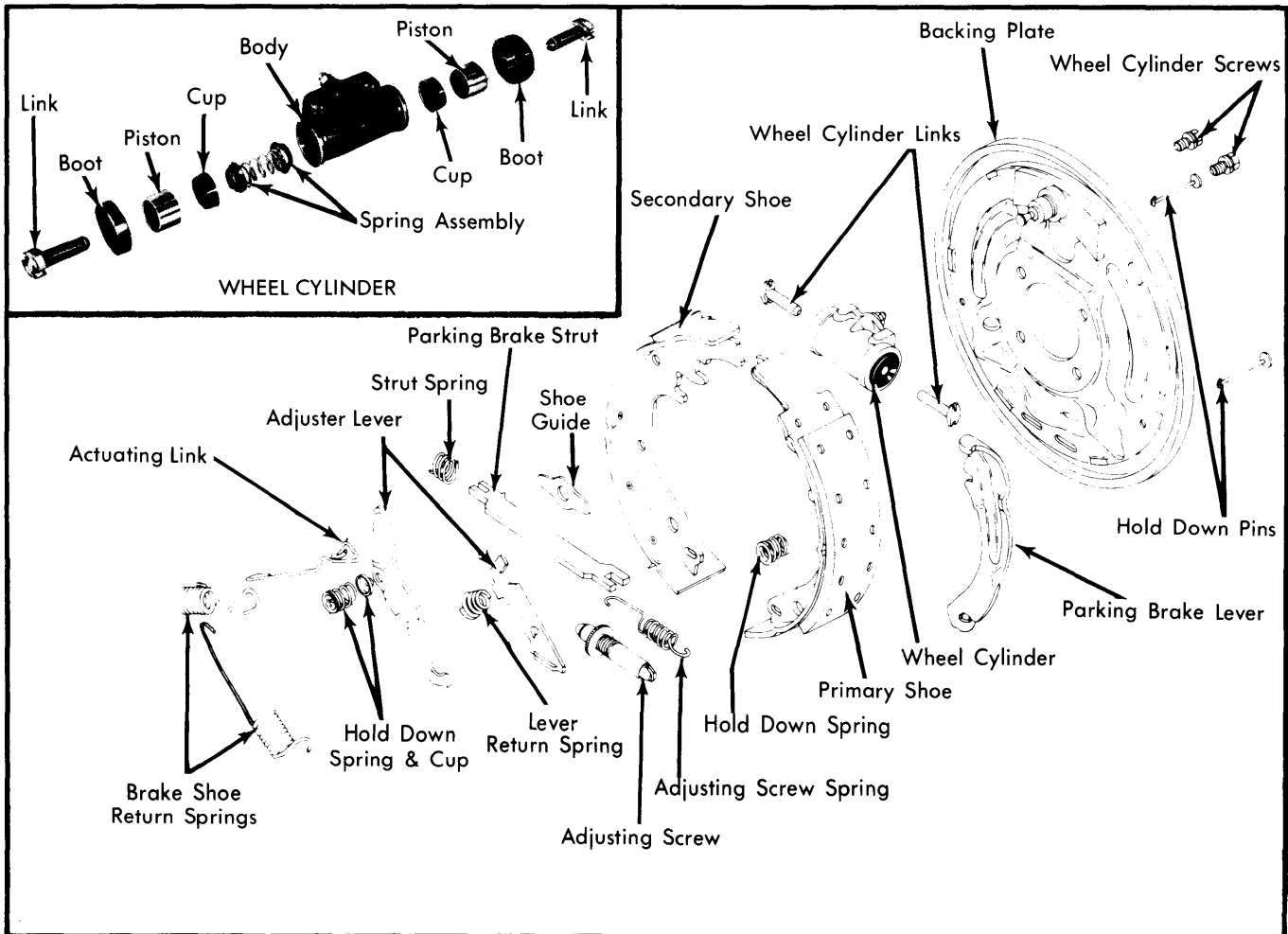
return springs. Remove hold down springs and cups. Lift actuator and unhook actuating link from anchor pin. Separate shoes from wheel cylinder connecting links, remove parking brake strut and spring, disconnect cable from parking brake lever, and remove shoes. Detach adjuster screw and spring from shoes. Remove parking brake lever.

**Installation** — Lubricate fulcrum end of parking brake lever, then attach to secondary shoe. Connect adjusting screw spring, then place screw in position (align star with adjusting hole).

**NOTE** — Ensure adjuster screws are installed in original positions. Lubricate shoe and cable contact surfaces on backing plate. Position shoes and insert into wheel cylinder links. Connect cable to parking brake strut and spring, between lever and primary shoe. Install actuator, actuator return spring, and actuating link. Replace hold down springs and return springs. Adjust brake shoe clearance as previously described.

### BLEEDING SYSTEM

See Hydraulic Brake Bleeding in this section.



**Fig. 5 Exploded View of Rear Drum Brake Assembly & Wheel Assembly (All Other General Motors Models Shown)**

# Brake Systems

## DELCO-MORAINE AUTOMATIC ADJUSTER (Cont.)

### TIGHTENING SPECIFICATIONS

Application	Ft. Lbs.	Application	Ft. Lbs.
Wheel Attaching Nuts		Oldsmobile (Cont.)	
Buick		88 W/403", 98, Custom Cruiser	100
Century, Skylark, Skyhawk	80	All Other Models	80
LeSabre W/7/16" Stud	80	Pontiac	
All Other Models	100	Steel Wheels	
Cadillac		Catalina, Bonneville	
All Models	100	W/4 3/4" Bolt Circle	80
Chevrolet		W/5" Bolt Circle	100
Impala, Caprice Sta. Wgn.	100	All Other Models	80
Camaro, Monza W/Alu. Wheels	90	Aluminum Wheels	
All Other Models	80	Catalina, Bonneville	
Oldsmobile		W/4 3/4" Bolt Circle	90
Toronado	130	W/5" Bolt Circle	100
		All Other Models	80

### BRAKE LINING SPECIFICATIONS

Application	Drum Diam.	Width		Length		Thickness	
		Front	Rear	Primary	Secondary	Primary	Secondary
<b>Buick</b>							
Skyhawk	9.5"	⊙	2.0"	7.63"	9.91"	.20"	.20"
Skylark	9.5"	⊙	2.0"	7.63"	9.91"	.19"	.27"
Century	9.5"	⊙	2.0"	7.50"	9.90"	.19"	.27"
LeSabre	9.5"	⊙	2.0"	7.63"	9.91"	.208"	.277"
Electra, Riviera, Estate Wagon	11.0"	⊙	2.0"	8.93"	11.58"	.232"	.272"
<b>Cadillac</b>							
Deville	11.0"	⊙	2.0"	8.95"	11.59"	.25"	.29"
Limousine, Commercial Chassis	12.0"	⊙	2.5"	11.00"	12.36"	.23"	.26"
<b>Chevrolet</b>							
Monza	9.5"	⊙	2.0"	7.30"	9.46"	.23"	.30"
Camaro, Nova	9.5"	⊙	2.0"	7.30"	9.46"	.23"	.23"
Chevrolet (Exc Police, Wagon)	9.50"	⊙	2.0"	7.58"	9.83"	.196"	.265"
Chevrolet Police & Wagon	11.0"	⊙	2.0"	8.86"	11.47"	.22"	.26"
Malibu, Monte Carlo	11.0"	⊙	2.0"	.....	.....	.....	.....
<b>Oldsmobile</b>							
Starfire	9.5"	⊙	2.0"	7.63"	9.91"	.19"	.27"
Omega (Exc. 5 Speed)	9.5"	⊙	2.0"	7.63"	9.91"	.19"	.27"
Omega (W/5 Speed)	11.0"	⊙	2.0"	9.00"	11.50"	.22"	.26"
Cutlass, 88 (Exc. 403")							
98, Toronado	11.0"	⊙	2.0"	9.00"	11.50"	.22"	.26"
88 (W/403" Eng.)	11.0"	⊙	2.0"	7.63"	9.91"	.19"	.27"
<b>Pontiac</b>							
Sunbird	9.5"	⊙	1.08"	7.30"	9.46"	.23"	.30"
Phoenix, Firebird	9.5"	⊙	2.0"	7.30"	9.46"	.23"	.23"
LeMans, Grand Prix	11.0"	⊙	.....	.....	.....	.....	.....
Catalina, Bonneville	11.0"	⊙	.....	.....	.....	.....	.....

⊙ — Equipped with front disc brakes.

# Brake Systems

## DELCO-MORAINE AUTOMATIC ADJUSTER (Cont.)

BRAKE SYSTEM SPECIFICATIONS				
Application	Drum Diam.	Wheel Cylinder Diameter		Master Cylinder Diameter
		Front	Rear	
<b>Buick</b>				
Skyhawk	9.5"	Ⓚ	.688"	.875"
Skylark	9.5"	Ⓚ	.938"	1.00"Ⓚ
Century	11.0"	Ⓚ	.938"	1.125"
LeSabre (Exc. Wagon), Riviera	11.0"	Ⓚ	.875"Ⓜ	1.125"
LeSabre Wagon, Electra	11.0"	Ⓚ	.938"	1.125"
<b>Cadillac</b>				
Deville	11.0"	2.938"Ⓚ	1.00"	1.125"
Limousine, Commercial Chassis	12.0"	2.938"Ⓚ	.938"	1.125"
<b>Chevrolet</b>				
Monza	9.5"	2.50"Ⓚ	.688"	.875"
Camaro, Nova	9.5"	2.938"Ⓚ	.938"	.938"Ⓜ
Chevrolet (Exc. Wagon & Police)	9.5"	2.938"Ⓚ	.875"	1.125"
Chevrolet Wagon & Police	11.0"	2.938"Ⓚ	.938"	1.125"
Malibu, Monte Carlo	11.0"	Ⓚ	.938"	.938"Ⓜ
<b>Oldsmobile</b>				
Starfire	9.5"	2.5"Ⓚ	.688"	.875"
Omega (Exc. 5 Spd.), 88 (w/403") 98, Toronado	11.0"	2.938"Ⓚ	.938"	1.0"Ⓜ
Omega (W/5 Spd.)	11.0"	2.938"Ⓚ	1.0"	1.0"Ⓜ
Cutlass	11.0"	2.5"Ⓚ	.75"	.813"Ⓜ
88 (W/403")	11.0"	2.938"Ⓚ	.875"	1.125"
<b>Pontiac</b>				
Sunbird	9.5"	2.5"Ⓚ	.688"	.875"
Phoenix, Firebird	9.5"	2.938"Ⓚ	.688"	1.0"Ⓜ
LeMans, Grand Prix	11.0"	2.5"Ⓚ	.75"	.866"Ⓜ
Catalina, Bonneville	11.0"	2.938"Ⓚ	.937"	.....

- Ⓚ — Front disc brakes.
- Ⓜ — Station wagons use .938" wheel cylinders.
- Ⓜ — Manual brakes, power brakes use 1.125" master cylinders.
- Ⓜ — Manual brakes, power brakes use .875" master cylinders.
- Ⓜ — Manual brakes, power brakes use .945" master cylinders.

BRAKE DRUM SPECIFICATIONS				
Application	Drum Diameter	Original Diameter	Maximum Refinish Diameter	Discard Diameter
<b>General Motors</b>				
All Models	9 1/2 "	9.500"	9.560"	9.590"
	11"	11.000"	11.060"	11.090"
	12"	12.000"	12.060"	12.090"