

## GENERAL MOTORS SINGLE PISTON DISC

Chevette

### DESCRIPTION

Caliper unit is constructed from a single casting which contains one large piston in inboard section of casting. Piston is constructed of nickle-chrome plated steel. Caliper unit is retained to mounting bracket by a single bolt, sleeve and bushings. Mounting bracket is bolted to rear side of steering knuckle. Brake rotor and hub are one piece. Brake rotor is cast iron using two machined braking surfaces (one on each side of rotor). Shoe and lining assemblies are constructed of stamped steel shoes with bonded linings. Inboard shoe is equipped with a spring steel wear sensor riveted to rear edge. When lining has worn to within .030" of shoe table, sensor contacts rotor, causing a very audible high frequency squeal.

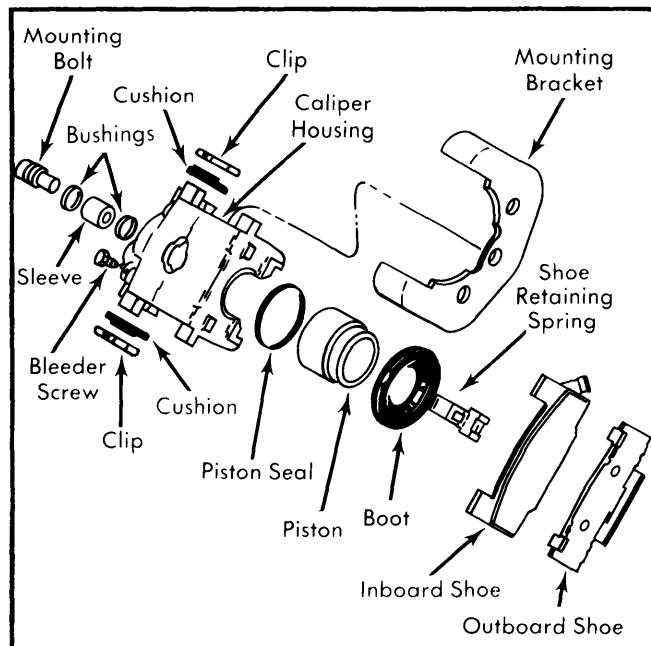

Fig. 1 Exploded View of Caliper Assembly

### ADJUSTMENT

Shoe wear is automatically compensated for by sliding caliper feature, therefore, no brake adjustment in service is required.

### SERVICING

#### BLEEDING

See Hydraulic Brake bleeding in this section.

#### SHOE & LINING INSPECTION

Inspect linings whenever a wheel is removed or tires are rotated. Check both ends of inboard and outboard linings for wear. Replace all linings if any lining is worn to within  $\frac{1}{32}$ " of shoe table.

#### SHOE & LINING REPLACEMENT

**NOTE** — Relining should be done in complete sets only.

**Removal** — 1) Remove and discard two-thirds of brake fluid in master cylinder. **CAUTION** — Do not remove brake line or completely empty master cylinder, or it will be necessary to bleed system. Raise vehicle and remove front wheels. Position a large "C" clamp on caliper with solid end on caliper housing and screw end on the metal back of inboard shoe. Tighten "C" clamp to bottom piston in caliper bore and then remove "C" clamp.

2) Remove two hex head bolts attaching mounting bracket to steering knuckle. **NOTE** — Support caliper assembly when last bolt is removed to prevent caliper from dropping and damaging hydraulic brake line. Do not remove the socket head retaining bolt. Slide caliper from rotor and hang with a wire or chain. Remove old shoe and lining assemblies. Remove shoe retaining spring from piston if it did not come out with shoes.

**Installation** — 1) Clean and inspect caliper. Check for hydraulic fluid leaks, boot cuts or other damage. Make sure caliper fits snugly in bracket without end play. If there is end play, replace or reposition rubber cushions between caliper and mounting bracket. Install shoe retaining spring on inboard shoe. Place shoes in caliper and slide assembly over rotor. Install and tighten mounting bolts.

2) Using large channel lock pliers, clinch outboard shoe tabs to caliper (both ends) with lower jaw of pliers on bottom edge of shoe and upper jaw on tab. After clinching, radial and end play should be 0-.005". Install wheels and lower vehicle. Fill master cylinder to within  $\frac{1}{4}$ " of top of reservoir. Pump brake several times and refill reservoir. **CAUTION** — Ensure solid brake pedal and full master cylinder reservoir before moving vehicle.

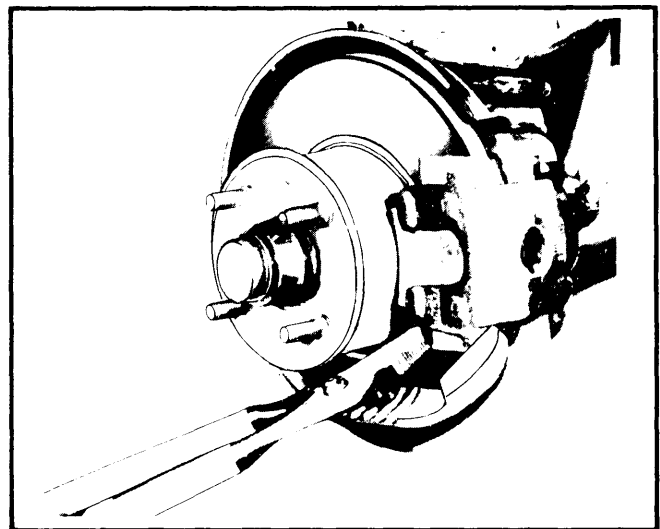

Fig. 2 Clinching Tabs of Outboard Shoe

#### ROTOR SERVICING

**Lateral Runout** — Adjust wheel bearings until all end play is eliminated. Attach a dial indicator to front suspension so that pointer contacts face of rotor approximately one inch from

# Brake Systems

## GENERAL MOTORS SINGLE PISTON DISC (Cont.)

edge of rotor. Set gauge to zero, then turn rotor through one complete revolution noting gauge. See *Rotor Specifications for maximum allowable runout.*

**Parallelism** – Check thickness of rotor at four or more points around circumference of rotor. Make all measurements at same distance from edge of rotor. If thickness varies more than specified, refinish or replace rotor as necessary. See *Rotor Specifications for refinish thickness.*

### REMOVAL & INSTALLATION

#### BRAKE CALIPER

Removal of caliper for overhaul is same procedure as for lining replacement, except it is necessary to disconnect brake hose.

### OVERHAUL

#### BRAKE CALIPER

**Disassembly** – Clean exterior of caliper using clean brake fluid and place on a clean working surface, then drain brake fluid from caliper. Remove socket head retainer bolt and slide mounting bracket off caliper. Remove sleeve and two bushings. Separate clips and cushions from sides of caliper. Using clean shop towels to pad interior of caliper, apply compressed air to caliper inlet and remove piston. **CAUTION** – Use only enough air pressure to ease piston out of bore. Using a screwdriver, pry boot out of caliper, then pry piston seal from caliper using a piece of wood or plastic. **CAUTION** – Do not use a metal tool to remove piston seal as bore may be damaged. Remove bleeder valve from caliper.

**Cleaning & Inspection** – 1) Boot, piston seal, rubber bushings and sleeve must be replaced each time caliper is overhauled. Clean all other parts in clean brake fluid, then dry using dry filtered compressed air. **NOTE** – Using lubricated shop air will leave a film of mineral oil on metal parts, which may damage rubber parts upon contact at reassembly. Check retainer bolt for corrosion, breaks in plating or other damage. **NOTE** – Do not attempt to clean bolt, replace it.

2) Check outside diameter of piston for scoring, nicks, corrosion, worn or damaged plating. If surface defects exist, replace piston. **CAUTION** – Do not attempt to refinish piston with abrasives. Check piston bore in caliper for scratches or other damage. Minor scratches or corrosion may be polished clean with crocus cloth. Thoroughly clean bore after polishing. Replace caliper if corrosion is not easily cleaned.

**Reassembly** – 1) Lubricate bore in caliper and new piston seal with clean brake fluid. Position seal in caliper bore groove. Lubricate piston with clean brake fluid, then assemble new boot into groove in piston, with fold facing open end of piston. Insert piston into caliper bore using care not to unseat seal. Do not force piston to bottom of bore. Position outer diameter of boot in caliper counterbore, then seat boot using suitable tool (J-23572).

2) Check boot installation to make sure retaining ring moulded into boot is not bent and that boot is installed completely below caliper face. Install bleeder screw. Place new cushions on caliper lugs with heavy section in lug recess and saw-toothed edges pointing outward. Liberally coat sleeve, bushings and unthreaded portion of retainer bolt with silicone grease. Place larger bushing in caliper mounting hole groove and install sleeve. Install small bushing in retainer bolt groove.

3) Clamp caliper in a vise with mounting lug up. Place clips over cushions and squeeze mounting bracket down over clips, aligning retainer bolt hole. Move bracket against retainer boss on caliper, install and tighten retainer bolt. **NOTE** – Considerable force may be required to squeeze bracket over cushions. Install brake hose, using a new copper gasket. **NOTE** – After caliper has been overhauled and installed, it must be bled.

### TIGHTENING SPECIFICATIONS

| Application                       | Ft. Lbs.     |
|-----------------------------------|--------------|
| Brake Hose-to-Caliper .....       | 32           |
| Caliper-to-Mounting Bracket ..... | 28           |
| Bracket-to-Steering Knuckle ..... | 70           |
| Bleeder Screws .....              | 70 INCH Lbs. |
| Wheel Attaching Nuts .....        | 70           |

### DISC BRAKE ROTOR SPECIFICATIONS

| Application | Disc Diameter | Lateral Runout | Parallelism | Original Thickness | Minimum Refinish Thickness | Discard Thickness |
|-------------|---------------|----------------|-------------|--------------------|----------------------------|-------------------|
| Chevette    | 9.68"         | .005"          | .0005"      | .433"              | .390"                      | .374"             |