

Collapsible Steering Columns

ALL MODELS

American Motors
Chrysler Corp.
Ford Motor Co.
General Motors

DESCRIPTION

Under head-on collision conditions, columns are designed to telescope at a controlled rate. If driver is thrown forward into steering wheel, column can telescope further at same controlled rate. Incorporated into columns is a two piece telescoping transmission gear shift tube interconnected by plastic inserts and shear pins, and a two piece telescoping steering shaft with upper and lower sections connected by plastic collars and pins. A mounting bracket connecting steering column and instrument panel, allows column to slide forward on impact, but blocks rearward movement towards driver.

NOTE — On Omni and Horizon (Chrysler Corp.) the two piece universal jointed steering shaft and collapsible dished steering wheel provide driver protection in event of a collision.

CAUTION — All elements of energy absorbing columns are sensitive to damage and must be handled with care to avoid stresses to the column which could shear or loosen the fasteners which provide column rigidity. It is imperative that only fasteners of the same or equivalent part number be used if replacement becomes necessary. Improper fasteners or non-specified torque values could result in failure of the unit.

INSPECTION

COLUMN SUPPORT & COMPONENTS

Column Support Bracket — Damage of bracket is indicated by separation of two break-away capsules which allow column to slip forward under severe impact. If capsules have moved more than $\frac{1}{16}$ " , some column collapse may have occurred. Replace damaged brackets and inspect column for collapsed jacket or steering shaft components.

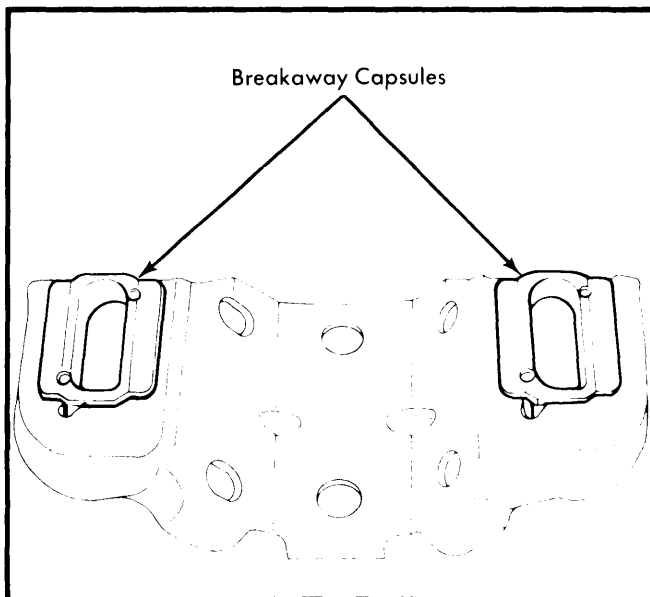

Fig. 1 Column Mounting Bracket

Column Jacket — Inspect jacket section of column for looseness, bends, collapsed mesh or bellows section. With General Motor's models, check mast jacket collapse by measuring distance from edge of neutral-start switch opening and bottom of upper jacket (see Fig. 2).

Shifter Shaft — Separation of shift tube or shaft assembly cannot be visually inspected without column disassembly. To check, hold lower end of shifter shaft and move shift lever through its ranges. If there is little or no movement at shifter shaft lower lever, plastic joints are sheared.

Steering Shaft — Inspect intermediate shaft and steering column shaft for injected plastic pins being sheared. The shafts will rattle when struck lightly from side and some lash may be felt when rotating steering wheel and holding coupling.

STEERING SHAFT & COUPLING ALIGNMENT

Flexible Fabric Coupling — Steering gear and column shaft must be in alignment to avoid coupling binding and metal-to-metal contact between shaft flanges. An improperly aligned column or steering gear may cause increased turning effort, directional pointing, lumpiness or popping noise. A hissing noise common to rotary valve power gears can be carried through steering shaft and inside vehicle if metal-to-metal contact exists at coupling. Coupling flange components should have at least $\frac{1}{16}$ " to $\frac{1}{8}$ " operating clearance at all times.

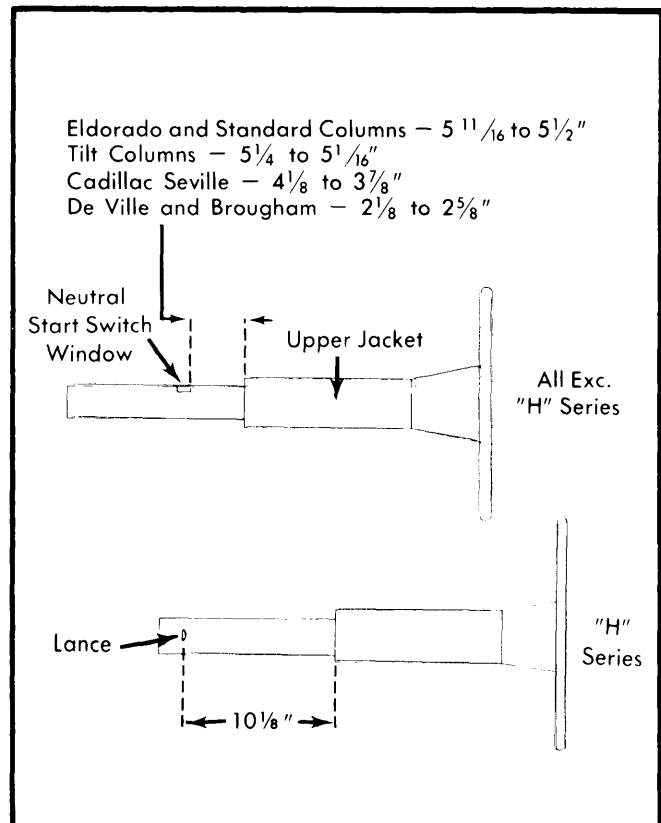

Fig. 2 G.M. Column Collapse Measurement

ALL MODELS (Cont.)

REMOVAL & INSTALLATION

CAUTION — When working on a collapsible steering column, do not bump or hammer on column components. With column removed from mounts, it is extremely susceptible to impact damage. A slight impact on column end may collapse steering shaft or loosen plastic injections which maintain column rigidity. When removing steering wheel, use a suitable puller but do not hammer on puller to aid removal.

Removal — 1) Center steering wheel and disconnect battery ground cable. Remove steering coupling shield if equipped. Disconnect steering shaft at flexible coupling or pot joint. Note coupling bolt size and location and mark shafts for reassembly reference. For vehicles with a universal joint and intermediate shaft, disconnect flex coupling and remove shaft. Disconnect column shift linkage from lever(s).

2) Remove steering wheel if necessary for removal clearance. Remove column trim pads, shrouds and instrument panel covers as required. Disconnect all electrical wiring to steering column and vacuum lines if equipped with automatic parking brake release on column. Disconnect shift quadrant cable or link from column shift bowl if equipped.

3) Move seat back as far as possible to provide removal clearance. **CAUTION** — Do not remove upper support first, as column may bend under its own weight. Remove floor pan trim cover and column lower supports. Remove bolts attaching upper bracket to column. Note number and position of shims for reinstallation. Remove column bracket fasteners and lower column. Disconnect wiring from ignition switch, turn signal switch and neutral start switch (if equipped). Carefully remove column guiding column shift levers through firewall.

NOTE — Correct column installation is important to prevent stress on collapsible components during mounting.

Installation — 1) Install upper column mounting bracket on column and tighten screws. Install toe pan seals over column if equipped. Install column assembly through floor pan, align steering shaft marks, engage coupling and tighten bolts. **NOTE** — Do not apply end loads to steering shaft.

2) Raise column and connect all electrical wiring and vacuum hoses (if equipped) between column and body. Loosely install bracket fasteners to hold column to instrument panel support. Install lower column toe pan seals, toe pan, clamp or screws. Tighten bolts and screws as required. Connect shift quadrant cable or link. With steering shaft coupling bolts tight and toe pan bolts tight, tighten upper column bracket-to-instrument panel support fasteners. **CAUTION** — Do not tighten column mounting bolts unless vehicle is on its wheels or suspension.

3) Inspect flexible coupling alignment making sure there is no distortion due to pot joint bottoming in either direction. The steering wheel should be free to rotate smoothly (front wheels off ground). If column coupling alignment is required, loosen column mounting and adjust as required. If vehicle has had frame damage, it may be necessary to loosen steering gear to adjust coupling alignment.

4) Install steering wheel and components if removed. Connect transmission shift linkage and adjust as required. Check adjustment of neutral start switch (if equipped). Adjust shift

quadrant indicator if necessary. Install instrument panel covers, shrouds and column trim pads. Connect battery ground cable and test steering column for proper operation.

DISASSEMBLY

NOTE — For tilt and telescoping steering columns, see Movable Steering Columns in this section.

American Motors & General Motors — 1) Disconnect battery ground and remove steering wheel. Remove column if necessary, however, steps one through four can be performed without column removal. Using a suitable tool, depress lock plate, remove snap ring, tool and lock plate. **CAUTION** — If column is out of vehicle, with lock plate snap ring removed, steering shaft may slide out of jacket. Remove turn signal cam, preload spring and thrust washer. Remove signal lever and hazard knob. Remove signal switch or position aside.

2) Place lock cylinder in "RUN" position. Insert a flat tool in slot next to switch mounting screw boss (right hand slot) and depress retainer in slot bottom to remove lock cylinder. Remove key warning buzzer switch and clip using needle nose pliers. **CAUTION** — Do not drop clip into column housing.

3) To remove ignition switch, steering column must be lowered. Place lock cylinder in "LOCK" position. If cylinder has already been removed, pull up on actuating rod until it stops and then push down one detent, which is "LOCK" position. Loosen steering column attachment at toe pan and instrument panel bracket. If equipped with shift quadrant cable, disconnect as required. Lower column to seat cushion. Remove ignition switch and disconnect wire harness connector.

4) Remove bearing housing as follows: If column shift, remove shift lever pin and lever. Remove housing to jacket bolts and carefully pull up on housing until free from jacket. Turn housing clockwise 90° so actuator rod can be pulled through bowl. Remove thrust cup, rack, spring, lock bolt and spring, shift gate and sector. Remove shift bowl and shroud from jacket. Remove lower bowl bearing from top of jacket.

5) Mount column in suitable holding fixture or clamp with a vise onto two column weld nuts. **CAUTION** — Do not clamp all four weld nuts or column will bend between weld nuts. Remove steering shaft. On models with automatic transmission, remove bearing adapter retainer, bearing and adapter assembly, and shift tube spring. With manual transmission column shift, remove bearing and adapter assembly and first/reverse lever, then remove screws from bearing at lower end. On all models, slide out shift tube assembly.

6) To reassemble column components, reverse disassembly procedure and note: Apply thin coat of lithium soap based grease to all friction parts during reassembly. Use only specified screws and tighten as required. On vehicles with manual transmission (column shift), place a .005" shim between 2nd-3rd (upper) lever and lever spacer; turn upper shift tube bearing down and tighten screws, then remove shim. Adjust shift levers and switches as required.

Collapsible Steering Columns

ALL MODELS (Cont.)

Chrysler Corp. — 1) Remove horn button and steering wheel. Remove turn signal switch and bearing retainer plate (if equipped). Remove ignition key lamp. Remove steering shaft snap ring. Remove column shift lever if equipped, and bearing housing. Remove bearing lower snap ring from shaft. Pry sleeve off steering shaft lock plate hub to expose pin. Remove lock plate groove pin (punch from end without grooves). Remove lock plate from shaft.

2) Remove shift indicator pointer if equipped. Remove buzzer switch and lock lever guide plate. With key in "LOCK" position, remove key. Release lock cylinder by pushing release spring with wire through hole provided. Remove ignition switch assembly and lock housing from jacket. For further disassembly, remove column. Remove steering shaft through column lower end.

NOTE — *Omni and Horizon procedures are similar except that upper bearing is retained in position by two snap rings on the shaft and the lower bearing is held in the jacket by a spring above the universal joint. Key cylinder must be in the unlocked position to allow removal of the shaft.*

3) With automatic transmission, remove shift tube by removing vacuum brake release (if equipped) and removing shift tube set screw located at column upper end. With manual transmission, remove lower bearing support screws at end of jacket and pull tube and lever assembly from jacket. To reassemble, reverse disassembly procedure and note following: Apply a thin coat of lithium soap grease to all friction parts during reassembly. Use only specified screws and tighten as required.

Ford Motor Co. — 1) Disconnect battery ground and remove steering wheel. Disconnect all electric connections to column. Remove turn signal lever and switch. Remove upper shaft snap ring. Loosen housing-to-column tube retaining nuts and remove bolts. Raise housing while tapping lightly on steering shaft with a plastic hammer to free bearing from shaft. Remove bearing and insulator from housing.

2) Remove steering column shroud. Place gear shift lever in "P" position. Turn ignition key to "ON" position. Insert a wire pin in lock cylinder hole inside column (half way down column). Press in on wire pin while pulling out on cylinder to remove. Remove lock cylinder spring clips. Insert screwdriver in recess of drive gear at bottom of lock cylinder housing. Turn lock drive gear counterclockwise three notches. Remove snap ring, washer and lock drive gear. Note relationship of drive gear to rack teeth for reassembly in same position.

3) Disconnect shift quadrant cable if equipped. Remove instrument panel section below column if equipped. For models equipped with Mini, Extruded Absorber-Type columns (except Mustang, Pinto and Bobcat), remove instrument cluster. With Mustang, Pinto and Bobcat, lower column to expose ignition switch. Disconnect rod connecting ignition switch actuator to ignition switch. Remove retaining clip at lower end of lock pin and discard. Remove lock pin and spring from actuator. **NOTE** — *A new retaining clip must be installed on lock pin if removed from actuator.*

4) Disconnect transmission shift rods at column end if necessary. Rotate steering column inner tube and housing to expose retaining bolts. Remove bolts and lift housing off column inner tube. Remove steering column and clamp in a vise using suitable holding fixture. Remove column jacket switches. Remove three screws holding lower bearing retainer to end of column and remove bearing assembly. Remove steering shaft from bottom of column. Remove column shift levers if equipped. Remove bolt holding shift tube to housing and separate tube and housing.

5) To remove steering shaft anti-rattle clips, draw a mark on lower shaft where upper and lower shaft sections form a joint line. Separate shaft sections. Remove and discard anti-rattle clips, install new clips during reassembly. To reassemble, reverse disassembly procedure and note following: Lubricate all friction surfaces with multi-purpose grease. Use only specified fasteners and components and tighten as required.

TIGHTENING SPECIFICATIONS

Application	Torque	Application	Torque
American Motors		Ford Motor Co.	
Column Mounting Bracket-to-Instrument Panel Nuts	10 Ft. Lbs.	Shaft to Flexible Coupling Bolt	20-30 Ft. Lbs.
Cover Retaining Screws	100 INCH Lbs.	Flexible Coupling Nuts	
Flexible Coupling Nuts	25 Ft. Lbs.	Convuluted Type.....	10-22 Ft. Lbs.
Intermediate Steering Shaft-to-Column Pinch Bolts	48 Ft. Lbs.	Extruded Type.....	20-37 Ft. Lbs.
Housing Retaining Screws (Std. Col.)	60 INCH Lbs.	Toe Plate Nuts.....	8-14 Ft. Lbs.
Housing Retaining Screws (Tilt Col.)	100 INCH Lbs.	Toe Plate Clamp Bolt	5-12 Ft. Lbs.
Ignition Switch Mounting Screws	35 INCH Lbs.	Vibration Brace Bolts	
Mounting Bracket-to-Column Bolts	20 Ft. Lbs.	Cougar and LTD-II Only	20-37 Ft. Lbs.
Steering Wheel Nut	25 Ft. Lbs.	Column to Brake Support	
Chrysler Corp.		Convuluted Type.....	13-27 Ft. Lbs.
Steering Wheel Nut	60 Ft. Lbs.	Extruded Type.....	20-37 Ft. Lbs.
Column Bracket-to-Column Bolt	120 INCH Lbs.	Steering Wheel Nut.....	30-40 Ft. Lbs.
Column Clamp Stud	20 INCH Lbs.	General Motors	
Column Clamp Stud Nut	110 INCH Lbs.	Dash Panel Bracket To Column.....	15 Ft. Lbs.
Support Plate Bolts	200 INCH Lbs.	Dash Panel Bracket To Dash.....	20 Ft. Lbs.
Flexible Coupling Bolts	200 INCH Lbs.	Flexible Coupling Pinch Bolt.....	30 Ft. Lbs.
		Floor Pan Cover Screws.....	35 INCH Lbs.
		Steering Column Retaining Nuts	20 Ft. Lbs.
		Steering Column To Inst. Panel.....	20 Ft. Lbs.
		Steering Wheel Nut.....	30-35 Ft. Lbs.
		Steering Coupling Nuts	18-20 Ft. Lbs.
		Turn Signal Switch.....	25 INCH Lbs.

Collapsible Steering Columns

ALL MODELS (Cont.)

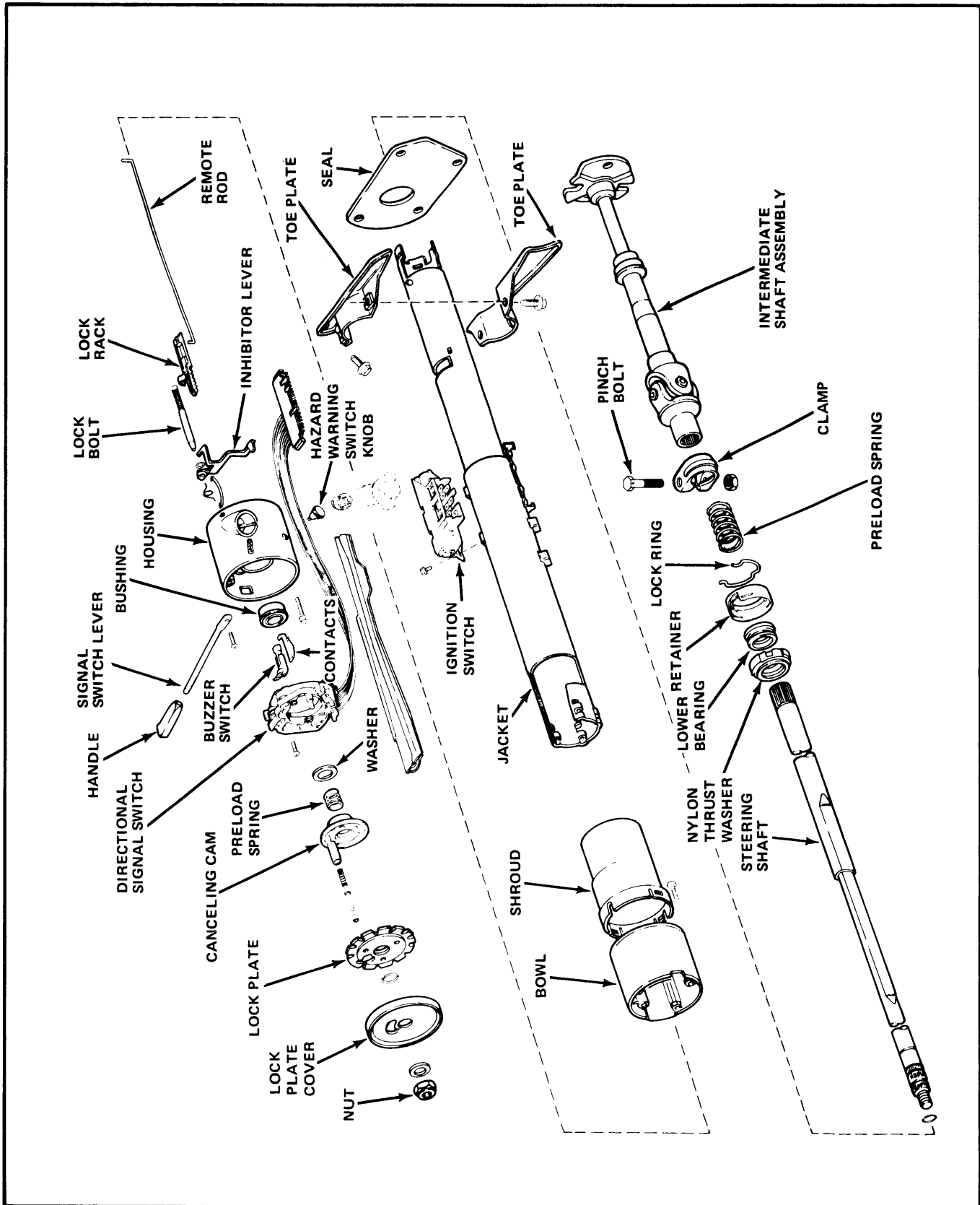

Fig. 3 American Motors Collapsible Column (Manual Transmission Only)

Collapsible Steering Columns

ALL MODELS (Cont.)

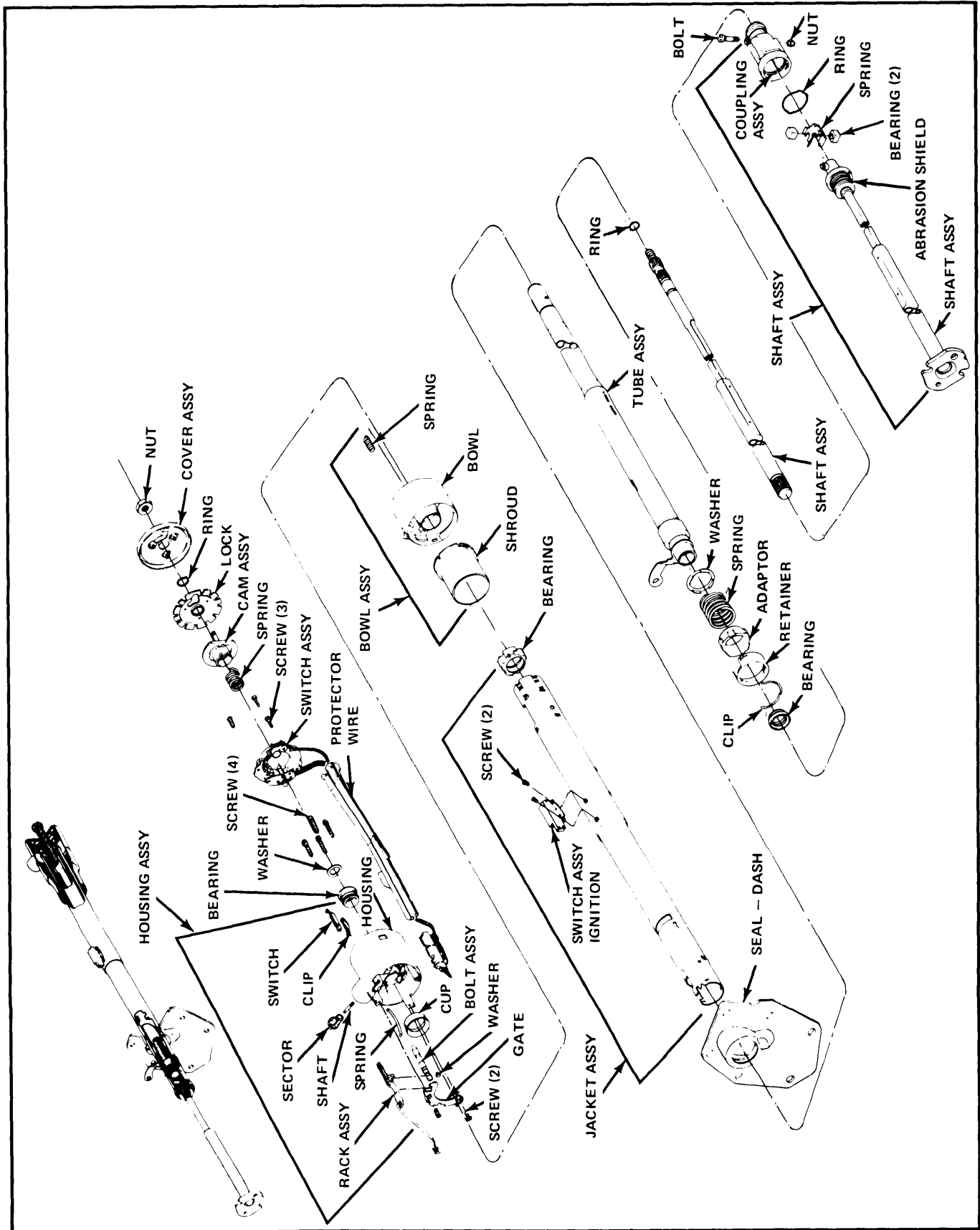

Fig. 4 American Motors & General Motors Collapsible Column

ALL MODELS (Cont.)

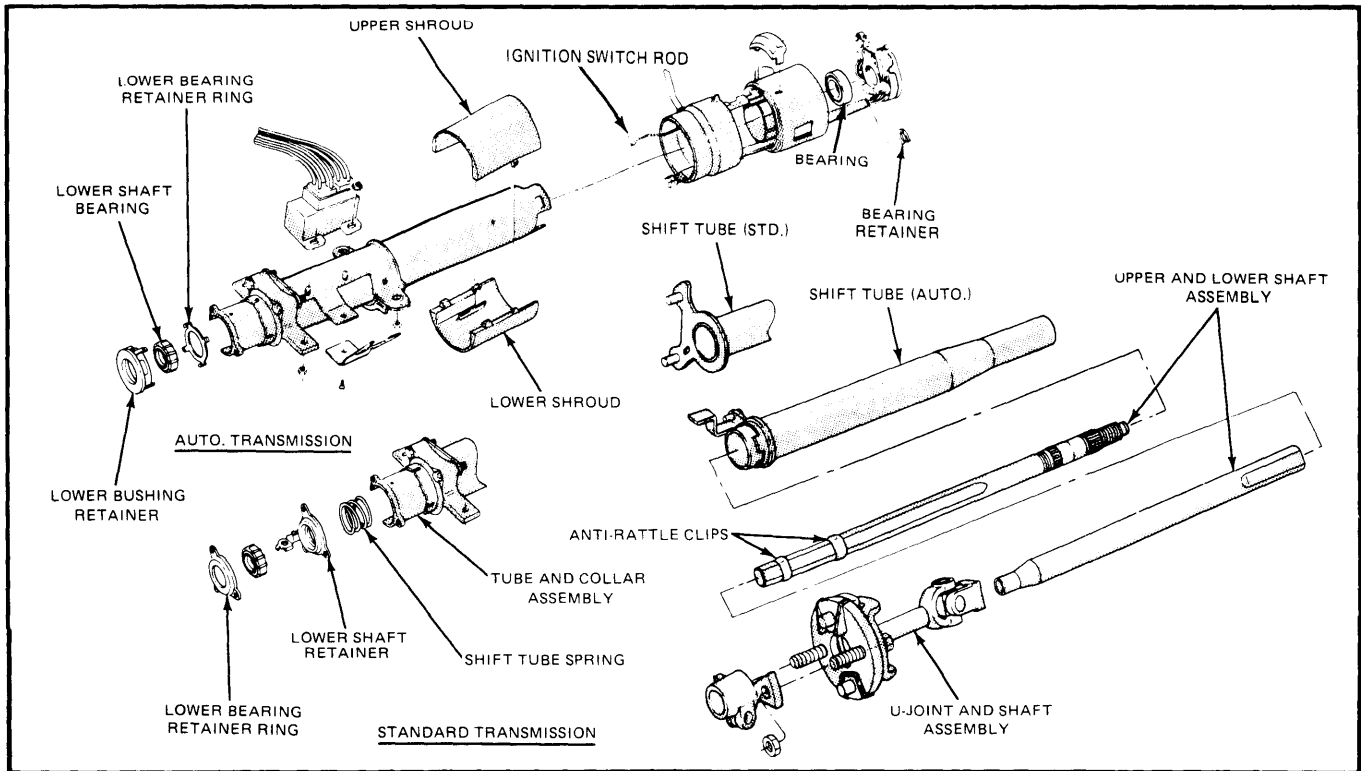

Fig. 5 Ford Motor Co. Mini Extruded Absorber Type Steering Column (LTD II, Cougar, Thunderbird & Mark V)

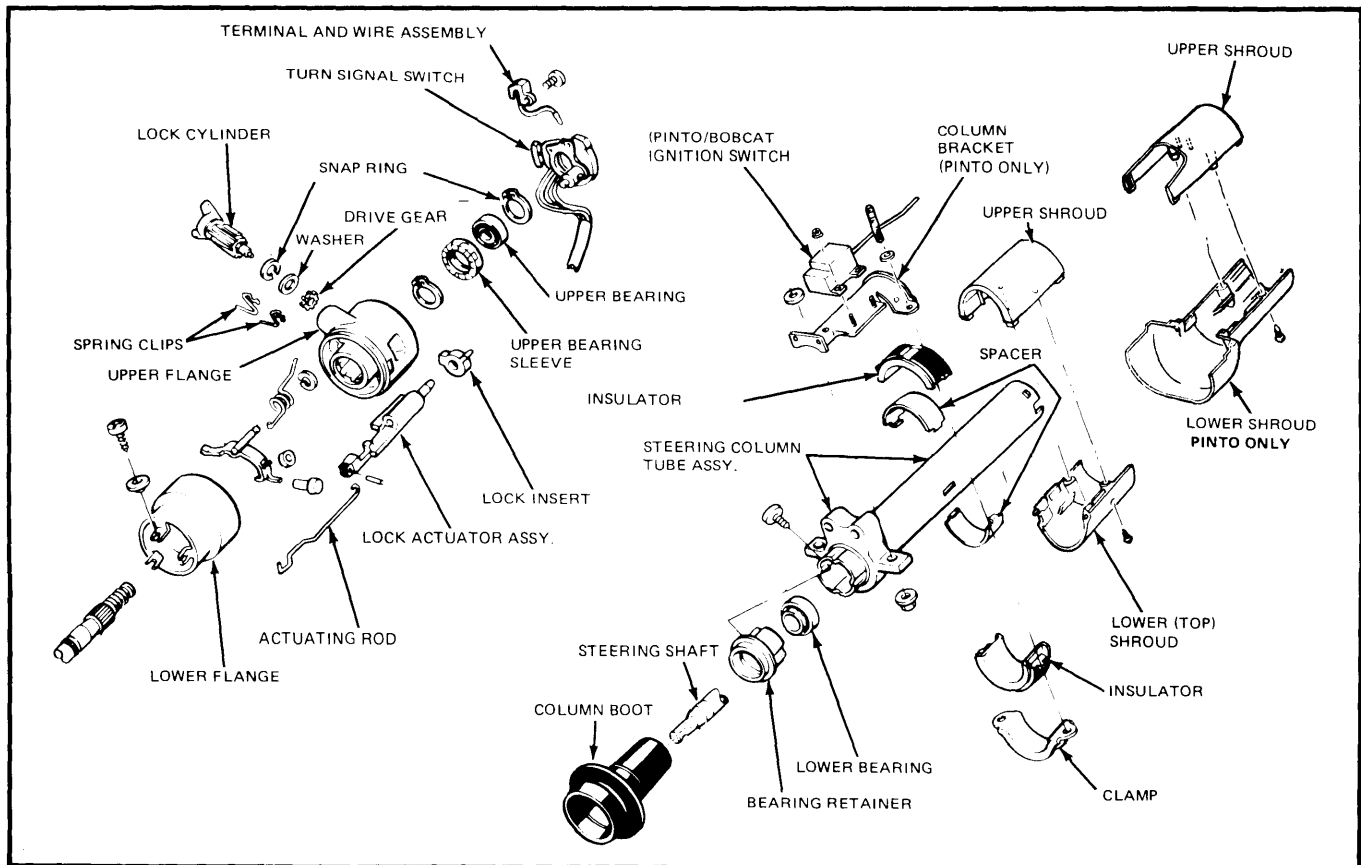

Fig. 6 Ford Motor Co. Bobcat, Mustang & Pinto Steering Column

Collapsible Steering Columns

ALL MODELS (Cont.)

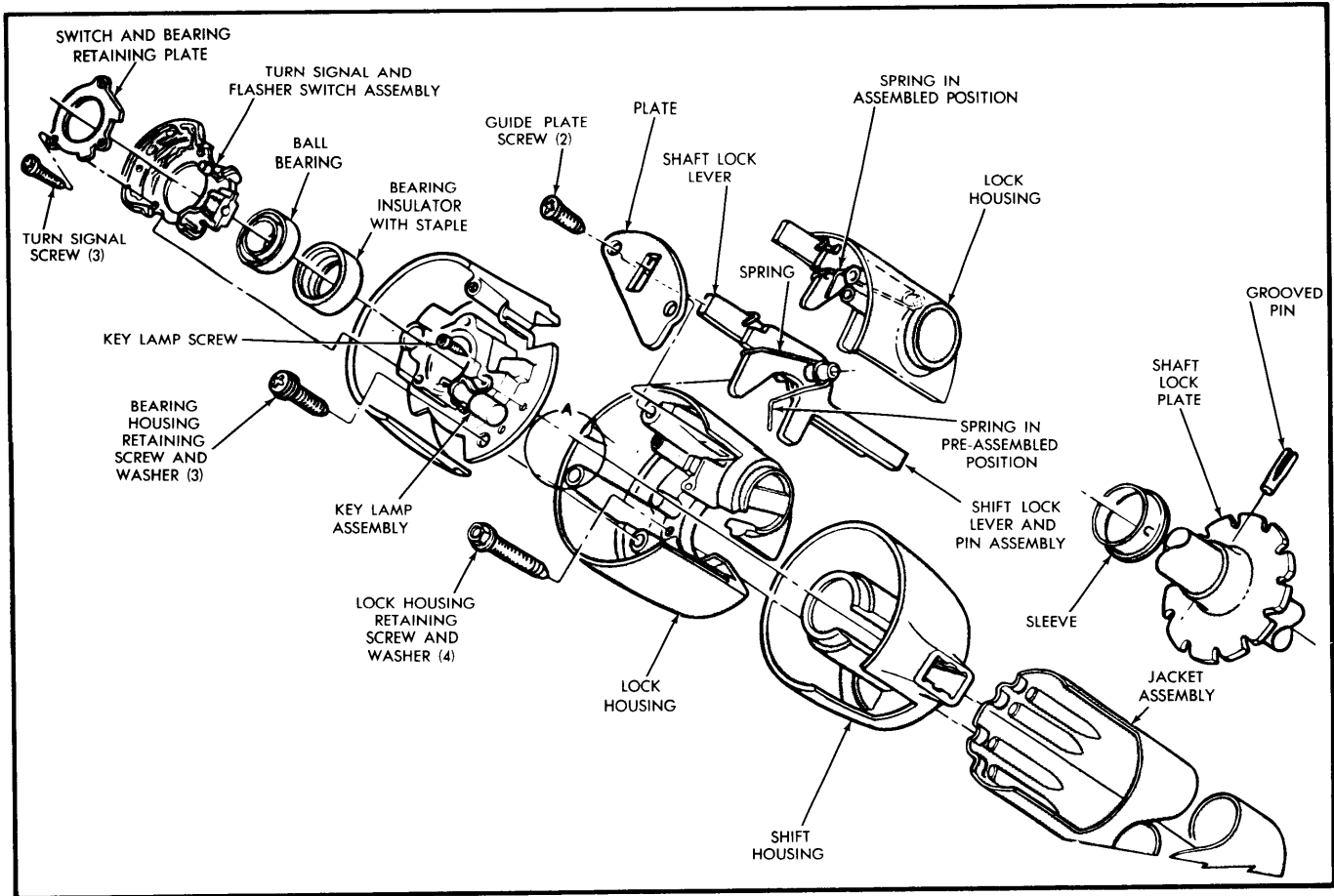

Fig. 7 Chrysler Corp. Steering Column Upper End

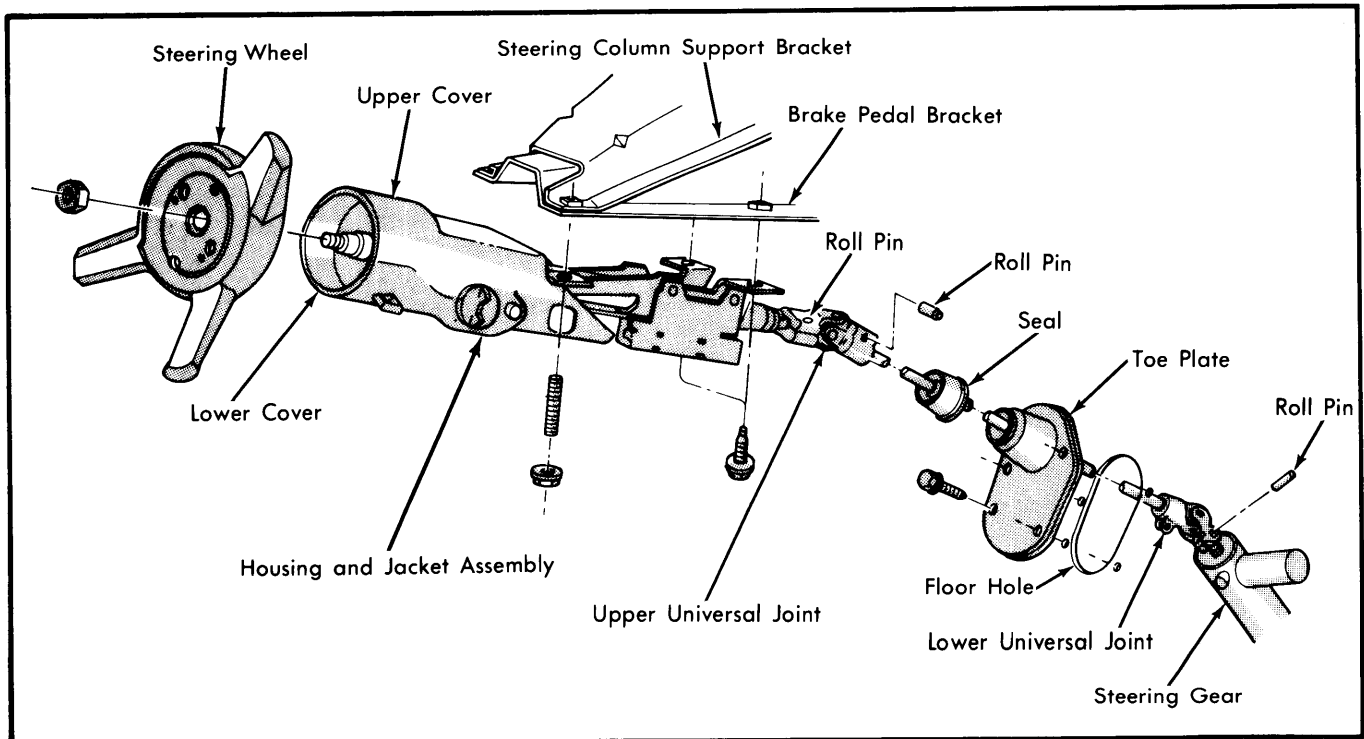

Fig. 8 Chrysler Corp. Omni & Horizon Steering Column Assembly