

CHEVETTE

Chevette

REMOVAL & INSTALLATION

DESCRIPTION

Ball joint independent front suspension with long and short control arms. Coil spring mounts between lower control arm and suspension crossmember. Shock absorber mounts between top of upper control arm and inner fender panel.

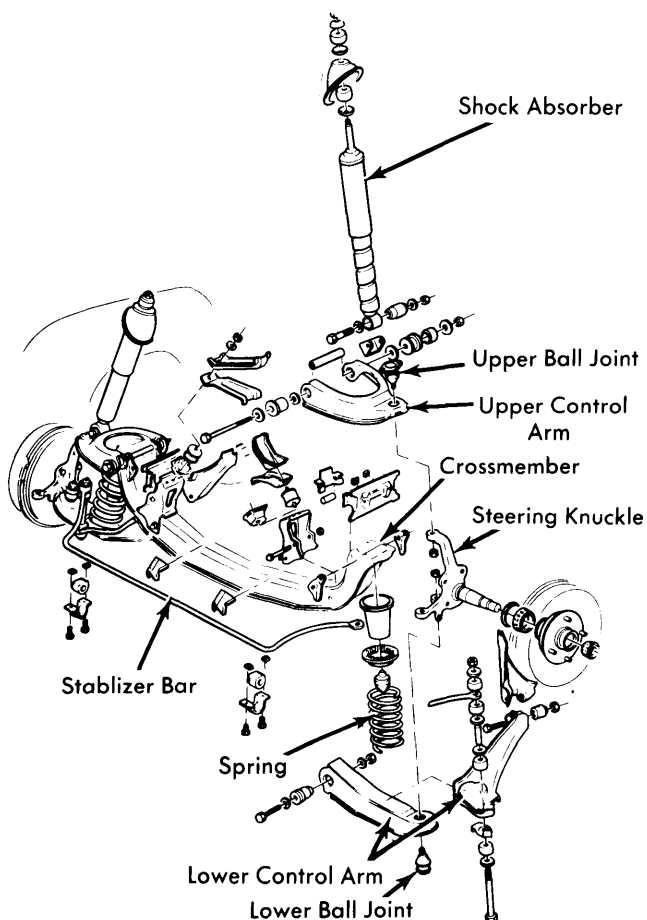

Fig. 1 Exploded View of Chevette Front Suspension Assembly

ADJUSTMENT

CASTER & CAMBER

See Caster and Camber Adjustments and Specifications in WHEEL ALIGNMENT Section.

RIDING HEIGHT

See Riding Height Adjustments and Specifications in WHEEL ALIGNMENT Section.

FRONT WHEEL BEARINGS

See Wheel Bearing Adjustment in WHEEL ALIGNMENT Section.

BALL JOINT CHECKING

See Ball Joint Checking in WHEEL ALIGNMENT Section.

UPPER & LOWER BALL JOINTS

Removal – Raise vehicle, remove wheel and tire assembly, and support lower control arm with floor jack. Loosen, but do not remove ball stud nut. Install suitable ball joint removal tool (J-26407) over cup end of ball joint and operate tool to free ball joint from steering knuckle. Remove tool and ball stud nut. Remove lower ball joint from control arm, or remove two nuts and bolts attaching joint to upper control arm and remove ball joint. Inspect tapered hole in steering knuckle. Remove any dirt present. If hole is deformed or damaged, steering knuckle must be replaced.

Installation – Install bolts and nuts attaching upper ball joint to control arm, then mate stud to steering knuckle; or mate lower ball stud through lower control arm and into steering knuckle. **NOTE** – Ball joints use a special nut which must be discarded whenever loosened and removed. On reassembly, use a standard nut to draw ball joint into position, then remove that nut and install a new special nut. Tighten ball joint stud nut. Install wheel and tire assembly and lower vehicle to floor.

LOWER CONTROL ARM & SPRING

Removal – Raise vehicle at frame and remove wheel and tire assembly. Disconnect stabilizer bar from lower control arm and tie rod from steering knuckle. Support lower control arm with jack and disengage lower ball joint from knuckle. Swing knuckle assembly out of way and secure with wire. Loosen lower control arm pivot bolts. Install safety chain on spring and slowly lower jack. When spring is extended as far as possible, pry spring over lower control arm seat and remove spring. Remove pivot bolts and lower control arm.

Installation – To install lower control arm and spring, reverse removal procedure making sure spring is installed in position shown in illustration. If necessary, have an assistant help compress spring to slide it over raised area on lower control arm.

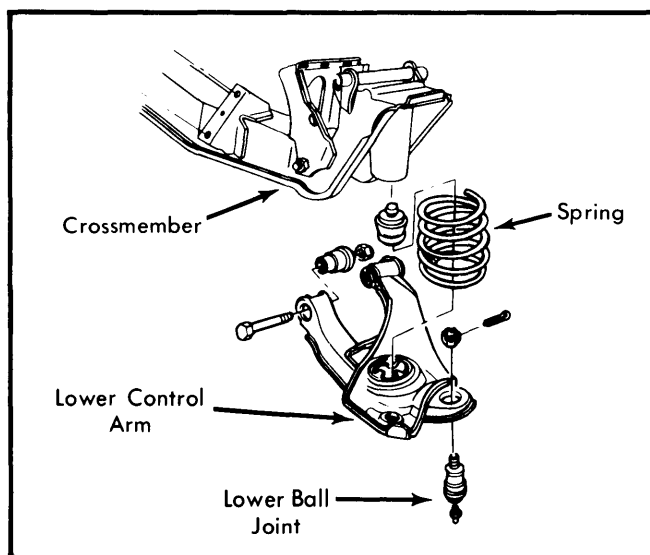

Fig. 2 View Showing Correct Positioning of Coil Spring

Front Suspension

CHEVETTE (Cont.)

UPPER CONTROL ARM

Removal — Raise vehicle on hoist and remove wheel and tire assembly. Support lower control arm with jack and disengage upper ball joint stud from steering knuckle. Remove control arm pivot bolts and remove control arm from vehicle.

Installation — To install, reverse removal procedure. Tighten pivot bolt nut with control arm in horizontal position.

STABILIZER BAR

Removal — Raise vehicle and remove stabilizer bolt and nut from lower control arm. Remove stabilizer bar bracket from body and remove bar.

Installation — To install, reverse procedure.

STEERING KNUCKLE

Removal — Raise vehicle and support lower control arm. Remove wheel and brake assemblies, hang caliper on wire out

of way. Remove tie rod end from knuckle and loosen both ball joint stud nuts and disengage studs from knuckle. Remove steering knuckle.

Installation — To install, reverse removal procedure.

TIGHTENING SPECIFICATIONS	
Application	Ft. Lbs.
Upper Ball Joint-to-Knuckle.....	33
Upper Ball Joint-to-Control Arm	29
Lower Ball Joint-to-Knuckle	48
Upper Control Arm Pivot Bolts	47
Lower Control Arm Pivot Bolts.....	49
Stabilizer Bar-to-Control Arm	15
Stabilizer Bar-to-Body	14
Shock Absorber	
Upper Mounting	7
Lower Mounting.....	43