

## CADILLAC – EXC. ELDORADO & SEVILLE

Cadillac, Except Eldorado & Seville

### DESCRIPTION

System is an independent spring type suspension, consisting of two upper and two lower control arm assemblies, coil springs, shock absorbers, a stabilizer bar and two integral steering arm and knuckles. Suspension is designed to produce an anti-diver reaction during braking.

### ADJUSTMENT

#### CASTER & CAMBER

See *Caster and Camber Adjustments and Specifications in WHEEL ALIGNMENT Section.*

#### RIDING HEIGHT

See *Riding Height Adjustments and Specifications in WHEEL ALIGNMENT Section.*

#### FRONT WHEEL BEARINGS

See *Wheel Bearing Adjustment in WHEEL ALIGNMENT Section.*

#### BALL JOINT CHECKING

See *Ball Joint Checking in WHEEL ALIGNMENT Section.*

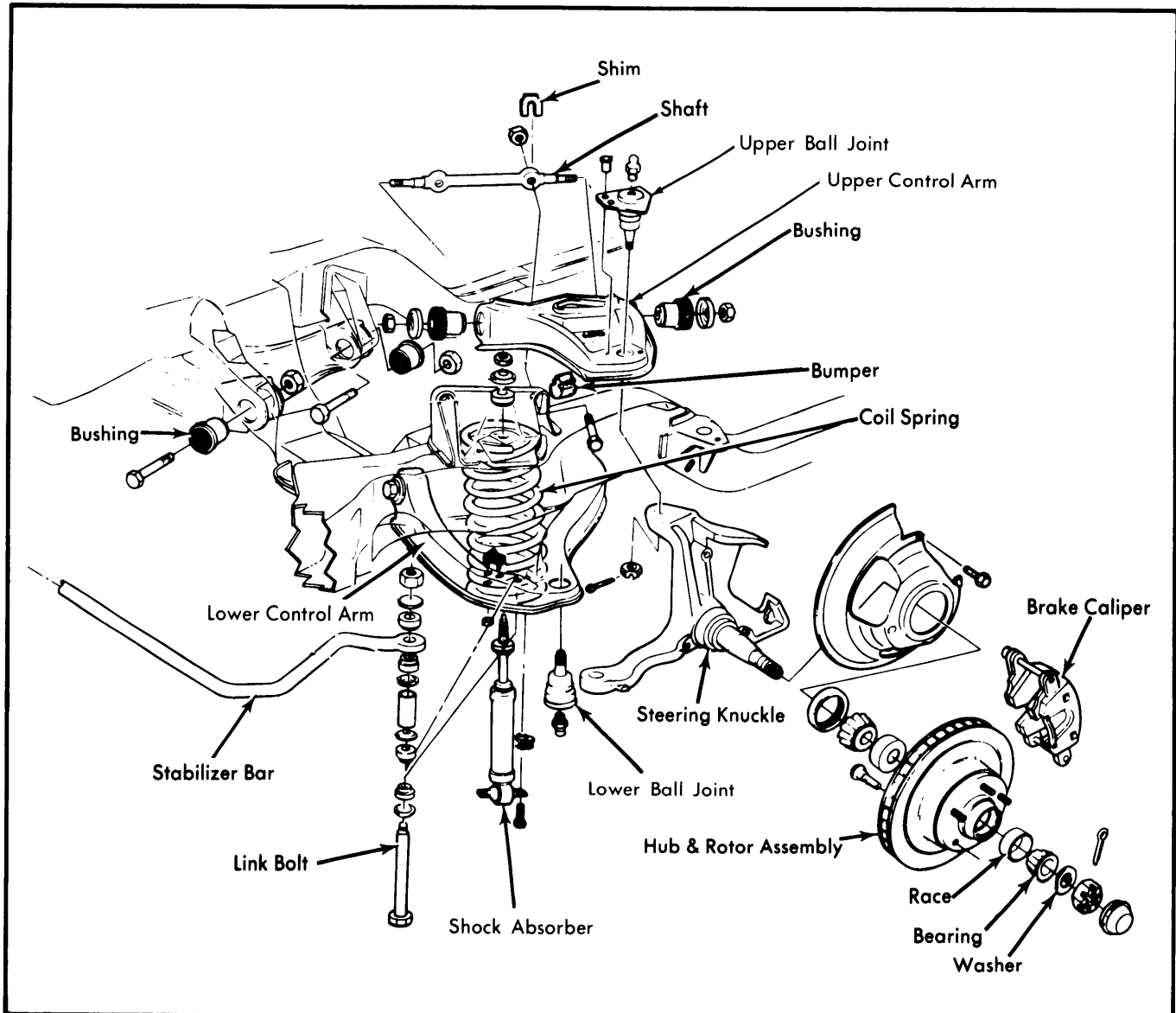

Fig. 1 Front Suspension (Exc. Eldorado & Seville)

# Front Suspension

## CADILLAC – EXC. ELDORADO & SEVILLE (Cont.)

### REMOVAL & INSTALLATION

#### STABILIZER BAR

**Removal** – Remove nuts, retainer and grommet from bottom of each stabilizer link. Unbolt stabilizer mounting brackets from frame. Remove rubber bushings from bar, then remove grommets, retainers, spacers, and links from ends of stabilizer bar. Turn wheels to full stop and work stabilizer from vehicle.

**Installation** – Position stabilizer and install rubber bushings and mounting brackets. Install grommets, retainers and nuts exactly as shown in suspension illustration. **NOTE** – Grommets and retainers are larger than those used on previous models, or on present shock absorbers. Ensure replacement parts are of correct size.

#### UPPER BALL JOINT

**Removal** – 1) Raise car and remove wheel and tire assembly. Remove cotter pin from upper ball joint stud. Remove caliper assembly and wire to frame so no strain is placed on brake hose.

2) Loosen (do not remove) stud nut about one turn. Using suitable tool (J-23742 or equivalent), turn threaded end of tool until stud is free of steering knuckle. **NOTE** – Lower control arm must be supported so chassis spring cannot force arm down.

3) Remove upper ball joint stud nut and swing knuckle out of way. Lift and support upper control arm with block of wood between frame and arm.

4) Remove rivets from upper control arm and drive out with a punch. **CAUTION** – Avoid damage to control arm or ball joint seat.

**Inspection** – Upper ball joint is spring loaded in its socket. If stud can be finger-twisted in its socket, or if stud has any lateral shake, replacement of ball joint is required.

**Installation** – 1) Install new ball joint in arm and attach with bolt and nut assemblies provided. Insert bolts from bottom. Ball joint stud cotter pin hole should run fore and aft. Remove wood support from upper arm and clean tapered hole in steering knuckle.

2) Connect upper arm stud to steering knuckle. Torque nut to 60 ft. lbs. and install new cotter pin. **NOTE** – Do not back off nut to install cotter pin. Rotate nut 1/6 turn maximum to align cotter pin slot.

3) Install caliper assembly, lubricate ball joint and install wheel and tire assembly. Check front wheel alignment and reset if necessary.

#### LOWER BALL JOINT

**Removal** – 1) Raise car and remove wheel and tire assembly. Remove lower ball joint stud cotter pin. Loosen stud nut no more than one turn. Do not remove nut.

2) Using tool (J-23742) between studs, turn threaded end of tool until stud is free of steering knuckle. **NOTE** – Ensure

lower control arm is supported so chassis spring cannot force arm down. Remove lower stud nut.

3) Work knuckle free from ball joint stud. Lift upper control arm, knuckle and hub assembly and support with block of wood between arm and frame. **NOTE** – Remove tie rod end only if necessary. Do not place strain on brake hose while moving arm assemblies.

4) Using proper tools, turn hex bolt until lower ball joint is forced out of control arm.

**Installation** – 1) Position ball joint in lower control arm. **NOTE** – Bleed vent in rubber boot of new ball joint should face inward. Using appropriate tools, turn down hex head bolt until joint is seated and remove tools. Align stud cotter pin hole fore and aft.

2) Remove wood support from upper control arm. Inspect tapered hole in steering knuckle and clean. Connect lower joint stud to steering knuckle and install stud nut. Torque nut to specification and install new cotter pin. **NOTE** – Do not back off nut for cotter pin installation. Turn nut 1/6 turn maximum to install cotter pin.

3) Lubricate ball joint, install tie rod end (if removed) and install wheel and tire assembly. Check front wheel alignment and reset as necessary.

#### UPPER CONTROL ARM

**Removal** – Raise and support front of vehicle at control arms. Remove wheel and tire assembly. Break loose upper ball joint, as previously described. Remove nuts, washers, and shaft mounting bolts at frame tower. Remove control arm and shaft assembly from vehicle.

**Bushing Removal** – Remove upper control arm. Remove bushing nuts. Using suitable tools (J-22269-5, J-24770-2 & J-24770-3), remove bushings (see Fig. 2).

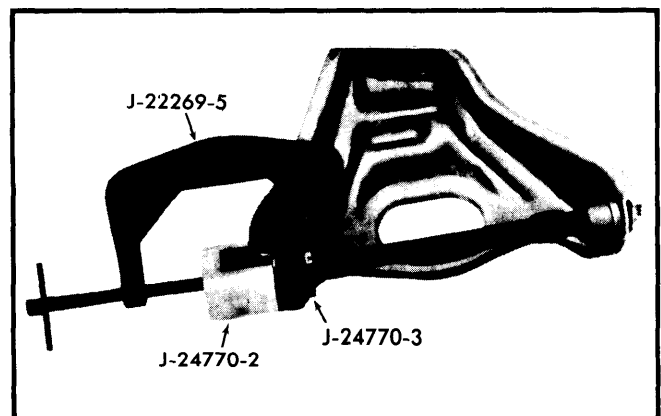
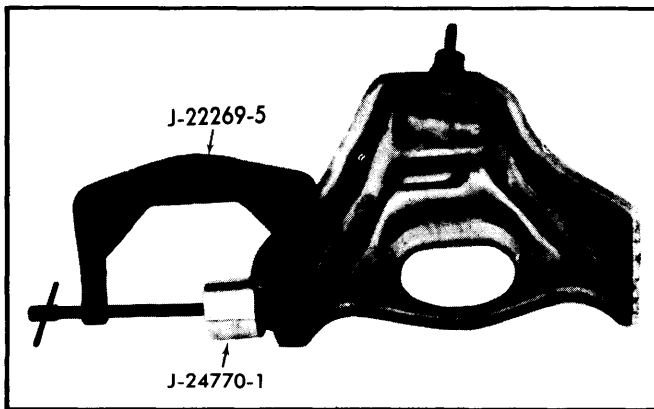

Fig. 2 Removing Upper Control Arm Bushing

**Bushing Installation** – Using same tools used for removal and Adaptor (J-24770-1), install bushings (see Fig. 3). Install bushing nuts loosely. Install upper control arm, and tighten bushing nuts.

## CADILLAC – EXC. ELDORADO & SEVILLE (Cont.)



**Fig. 3** Installing Upper Control Arm Bushing

**Installation** – Reverse removal procedure noting the following: Do not back off ball joint stud nut for installation of cotter pin. Tighten stud nut 1/6 turn maximum for cotter pin installation.

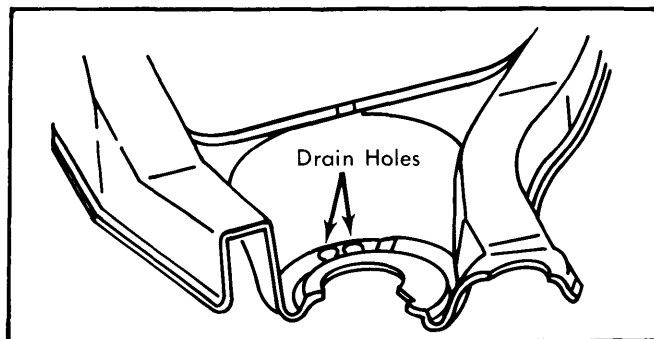

**Fig. 4** Coil Spring Positioning

### COIL SPRING

**Removal** – Raise car and remove two lower shock absorber screws. Push shock up through control arm into spring. Remove wheel and tire assembly. Position jack under outboard end of control to support arm. Disconnect stabilizer bar attachments and raise jack to remove tension on pivot bolts. **NOTE** – Secure chain around spring and through lower control arm as safety measure. Remove rear pivot bolt first and then remaining nuts and bolts. Lower control arm and remove spring when free. **CAUTION** – Do not use force to remove spring. Spring is easily removed when correct procedures are followed.

**Installation** – Position spring into frame so lower end of coil covers all or part of one inspection hole in lower control arm. Second hole must be partly or completely uncovered (see Fig. 4). Position lower arm in frame. Install front pivot bolt first and remaining bolts and nuts. On Fleetwood Brougham and DeVille, rear bolt must be installed in same direction as removed. Reverse removal procedure to complete installation.

### LOWER CONTROL ARM

**Removal & Installation** – Remove coil spring. Remove ball joint stud from steering knuckle and remove lower control arm

from vehicle. To install, place lower ball joint stud into steering knuckle boss and install nut and new cotter pin. Tighten nut 1/6 turn maximum to install cotter pin. Install coil spring. Reverse removal procedure to complete assembly.

**Bushing Removal** – Raise car and support frame with safety stands. Disconnect lower shock absorber attachments and push shock up through coil spring. Using suitable tool (J-23028-01) and jack, position under lower arm bushings so bushings seat in grooves of tool. As a safety precaution, install chain around lower arm and through coil spring. Removing rear bolt first, unbolt all lower control arm pivot attachments. Release tension on lower control arm slowly and install spacer (J-21474-12). **CAUTION** – Do not try to remove bushing without spacer being in position or distortion of arm will result. Install correct tools as shown in Fig. 5. Turn hex bolt and nut to press old bushing out. **NOTE** – When removing front bushing, remove bushing flare by tapping on edge with hammer.

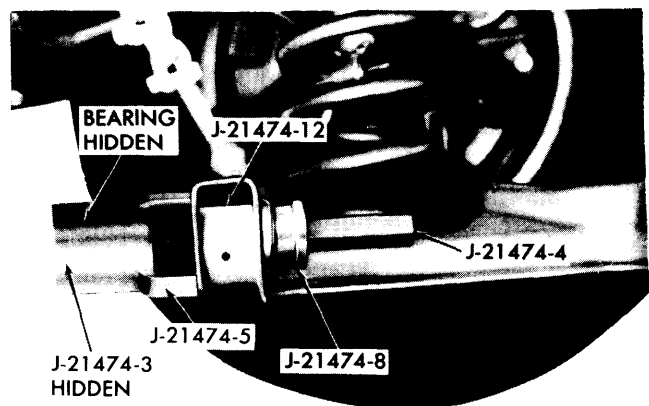

**Fig. 5** Removing Lower Control Arm Bushing

**Bushing Installation** – Position new bushing and install correct tools as shown in Fig. 7. Using spacer (J-21474-12), turn hex bolt and nut until new bushing is seated. When installing front bushing, use flaring tool (J-23915) and flare bushing (see Fig. 6). Reverse removal procedure to complete assembly.

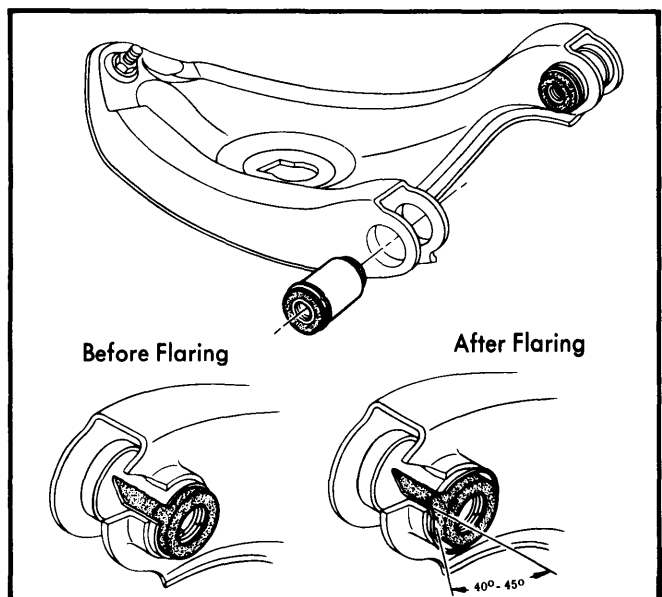

**Fig. 6** Lower Control Arm Front Bushing Flaring

# Front Suspension

## CADILLAC – EXC. ELDORADO & SEVILLE (Cont.)

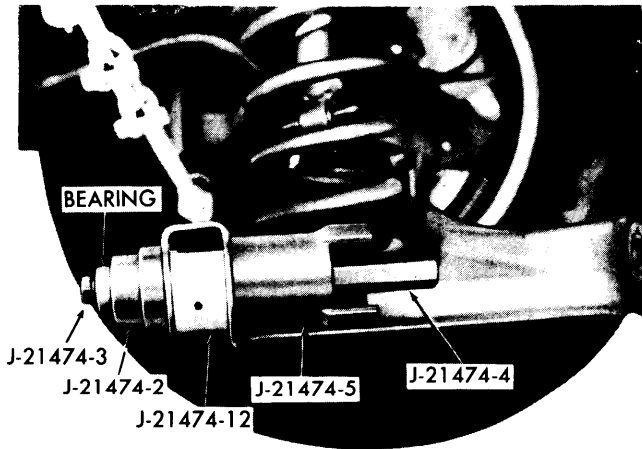

**Fig. 7** Installing Lower Control Arm Bushing

### STEERING KNUCKLE

**Removal** – Raise car and support lower control arms. Remove wheel and tire assembly and remove tie rod end from steering knuckle. Remove brake caliper, rotor and hub assembly. **NOTE** – Do not strain brake hose with weight of caliper. Remove splash shield, upper and lower ball joints and studs from steering knuckle.

**Installation** – Place steering knuckle in position and install upper and lower ball joint studs in bosses. Install stud nuts and new cotter pins. Tighten nuts maximum of 1/6 turn to align cotter pin holes. Do not back off nut for cotter pin installation. Install splash shield, hub and rotor assembly, outer bearing, washer and spindle nut. Adjust wheel bearings. See **WHEEL BEARING ADJUSTMENT** Section. Install brake caliper, wheel and tire assembly and lower car. Check front wheel alignment and reset as necessary.

### TIGHTENING SPECIFICATIONS

Application	Ft. Lbs.
Splash Shield-to-Knuckle .....	7
Lower Ball Joint-to-Knuckle .....	Ⓢ80
Upper Ball Joint-to-Knuckle .....	60
Stabilizer Bracket-to-Frame .....	24
Upper Control Arm-to-Frame Nuts .....	75
Control Arm Shaft Attaching Nuts .....	75
Lower Control Arm-to-Frame .....	75
Tie Rod Pivots-to-Knuckle .....	35
Shock Absorber Lower Bolts .....	22
Stabilizer Link Nut .....	12

Ⓢ – Limousine & Commercial – 90 ft. lbs.