

# Front Suspension

## FORD MOTOR CO., ENCLOSED SPRING

Ford & Mercury  
Lincoln & Mark IV  
Mustang, Pinto & Bobcat  
Thunderbird, Cougar & LTD II

### DESCRIPTION

The front suspension is a ball joint type with a coil spring located between the upper and lower control arms. The upper control arm pivots on bushings located on a shaft assembly which is bolted to the frame. The lower arm pivots on a bolt attached to the number 2 crossmember. This suspension is similar to the spring tower suspension used on other models except for the location of the coil spring. On the spring tower models the spring is located above the upper control arm. See *Ford Motor Co., Spring Tower* in this Section.

### ADJUSTMENT

#### CASTER & CAMBER

See *Caster and Camber Adjustments and Specifications in WHEEL ALIGNMENT* Section.

#### RIDING HEIGHT

See *Riding Height Adjustments and Specifications in WHEEL ALIGNMENT* Section.

#### FRONT WHEEL BEARINGS

See *Wheel Bearing Adjustment in WHEEL ALIGNMENT* Section.

#### BALL JOINT CHECKING

See *Ball Joint Checking in WHEEL ALIGNMENT* Section.

### REMOVAL & INSTALLATION

#### BALL JOINTS

**NOTE** — Upper and lower control arms must always be replaced as an assembly. Do not install ball joints or other components in used control arm.

#### STABILIZER BAR BUSHING

**Removal (Mustang, Pinto & Bobcat)** — Remove nut attaching stabilizer bar to link assembly. Remove bushing at top and bottom of stabilizer bar.

**Removal (All Others)** — Remove nut, washer, and insulator from lower end of stabilizer bar attaching bolt. Remove bolt and remaining washers, insulators, and spacer.

**Installation (All)** — Install stabilizer bar end bushing by reversing removal procedure. Tighten attaching hardware.

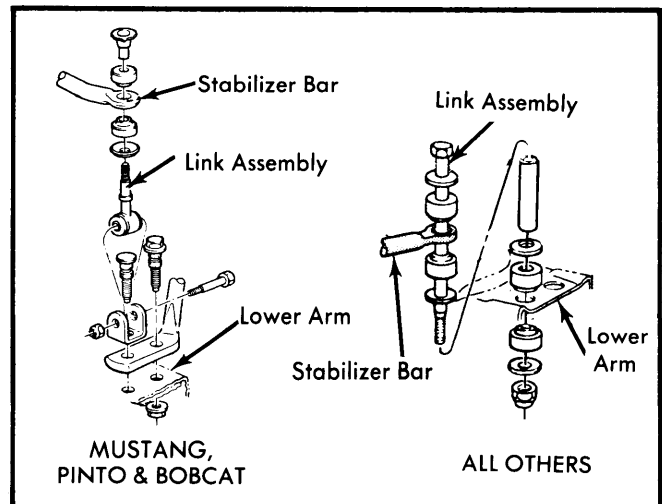

Fig. 1 Exploded View of Stabilizer Bar Bushings

#### STABILIZER BAR INSULATOR

**Removal & Installation** — Raise vehicle high enough to provide working space. Place supports under both front wheels. Disconnect stabilizer from each link, disconnect stabilizer attaching brackets, then remove stabilizer. Using a suitable rubber lubricant, replace insulators on stabilizer. To install, reverse removal procedure making sure that stabilizer

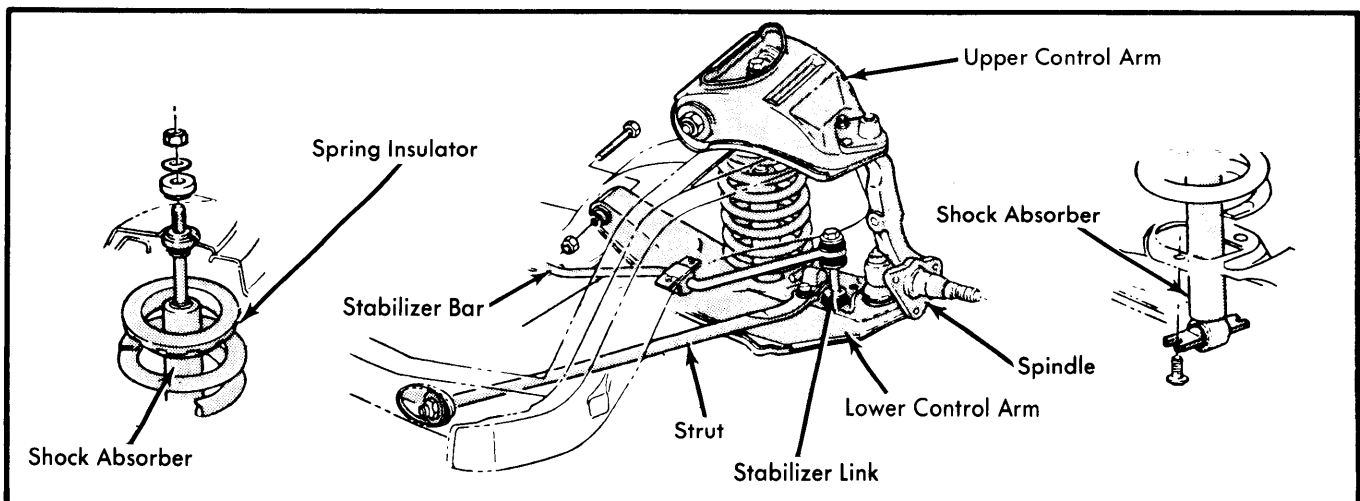

Fig. 2 Exploded View of Ford Enclosed Spring Type Front Suspension

## FORD MOTOR CO., ENCLOSED SPRING (Cont.)

link does not interfere with brake hoses. **NOTE** — New stabilizer bar-to-lower control arm nuts and bolts should be installed each time bar is removed.

### LOWER ARM STRUT AND/OR BUSHING

**Removal & Installation** — Remove nut from lower arm strut at frame, then remove washer and bushing from the strut. Remove nuts, washers, and bolts attaching strut and rubber bumper to lower arm. **NOTE** — Pinto, Mustang and Bobcat models are not equipped with rubber bumper at this point. Pull strut from frame. Remove rear side bushing and washer from strut. Install strut by reversing removal procedure. Check wheel alignment and adjust as necessary.

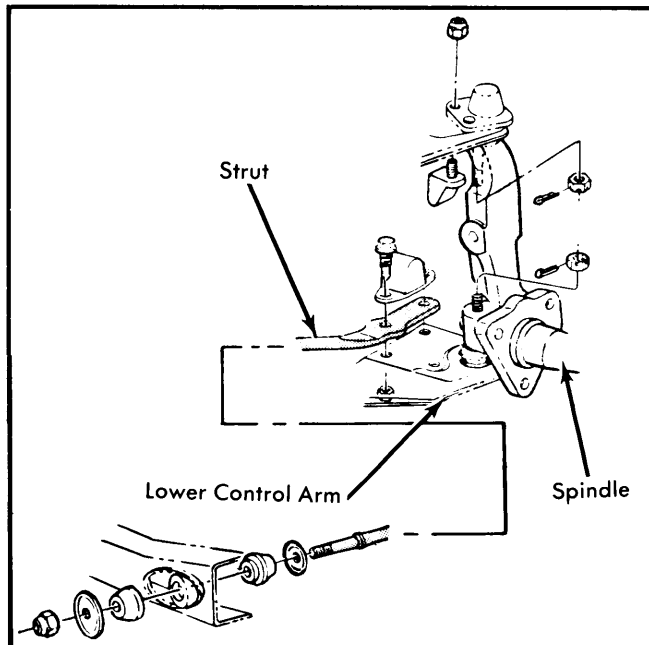

Fig. 3 Exploded View of Ford and Mercury Strut and Bushing Assembly

### COIL SPRING

**Removal** — Raise vehicle and place on safety stands. Disconnect lower end of shock absorber from lower arm. It may be necessary to use a pry bar to loosen lower end. On Pinto, Bobcat, and Mustang, remove nut that retains shock absorber to crossmember and remove shock absorber. Place a jack under lower arm, then remove bolts that attach the strut and rubber bumper to lower arm. If equipped with sway bar, disconnect lower end of sway bar stud or link from lower control arm. Disconnect inner end of lower control arm from crossmember. Carefully and slowly lower the lower control arm to relieve the spring tension. Remove spring.

**Installation** — To install, reverse removal procedure while noting the following: Coil spring must be positioned on lower arm so that end of spring is no more than  $\frac{1}{2}$ " from end of depression in arm. Do not torque lower arm-to-crossmember bolt until car is resting at curb height.

### LOWER CONTROL ARM

**Removal** — 1) Raise front of vehicle and position safety stands under both sides of frame just back of lower arms, then

remove wheel and tire. Disconnect lower end of shock absorber, and push it up to retracted position. If equipped with sway bar, disconnect lower end of link from lower control arm. Remove cotter pins from upper and lower ball joint stud nuts. Remove bolts and nuts attaching strut to lower arm.

2) Loosen lower ball joint stud nut one or two turns. **CAUTION** — Do not remove nut from stud at this time. Install suitable tool (T74P-3006-A for Pinto, Bobcat & Mustang, T57P-3006-B for all others) between upper and lower ball joint studs. **NOTE** — Tool must be seated firmly against ends of both studs and not against stud nuts.

3) Turn adapter screw with a wrench until tool places stud under tension. Tap spindle near lower stud with a hammer to loosen stud in spindle. **NOTE** — Do not loosen stud from spindle with tool pressure only. Position floor jack under lower arm. Remove ball joint nut and use jack to lower arm from spindle. Remove spring and insulator. Remove nut and bolt attaching lower arm to crossmember and remove arm.

**Installation** — To install, reverse removal procedure noting the following: Do not torque lower arm-to-crossmember bolt until vehicle is resting at curb height. Coil spring must be positioned on lower arm so that end of spring is no more than  $\frac{1}{2}$ " from end of depression in arm.

### UPPER CONTROL ARM

**Removal** — 1) Raise front of vehicle and position safety stands under both sides of frame just back of lower arm. Remove wheel cover, then remove wheel and tire from hub. Remove cotter pin from upper ball joint, then loosen stud nut one or two turns. **CAUTION** — Do not remove nut at this time. Install suitable tool (T74P-3006-A for Pinto, Bobcat & Mustang, T57P-3006-B for all others) between upper and lower ball joint studs with adapter screw on top. **NOTE** — Tool must be seated firmly against ends of both studs and not against stud nuts.

2) Turn adapter screw with a wrench until tool places stud under tension. Tap spindle near upper stud with a hammer to loosen stud in spindle. **NOTE** — Do not loosen stud from spindle with tool pressure only. Remove tool from between ball joint studs and place floor jack under lower arm. Raise floor jack to relieve pressure from upper ball joint stud nut and remove nut. Remove upper arm inner shaft attaching bolts. Remove upper control and inner shaft as an assembly. Remove bumper from upper arm.

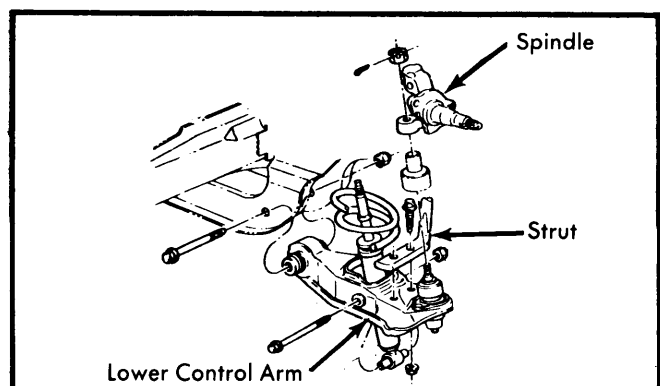

Fig. 4 Exploded View of Mustang, Pinto & Bobcat Lower Control Arm Assembly

# Front Suspension

## FORD MOTOR CO., ENCLOSED SPRING (Cont.)

**Installation** — To install, reverse removal procedure noting the following: Be sure wheel bearings are properly adjusted, and wheels properly aligned before operating vehicle.

### UPPER CONTROL ARM BUSHINGS

**Removal (Pinto, Bobcat & Mustang)** — With control arm removed from vehicle, use suitable tool (T74P-3044-A) to install shaft locator on inner shaft to prevent it from rotating. Position a suitable remove adapter, remover receiver, and "C" frame assembly on end of shaft and remove bushing. Repeat procedure on other end of shaft to remove second bushing and remove shaft from arm.

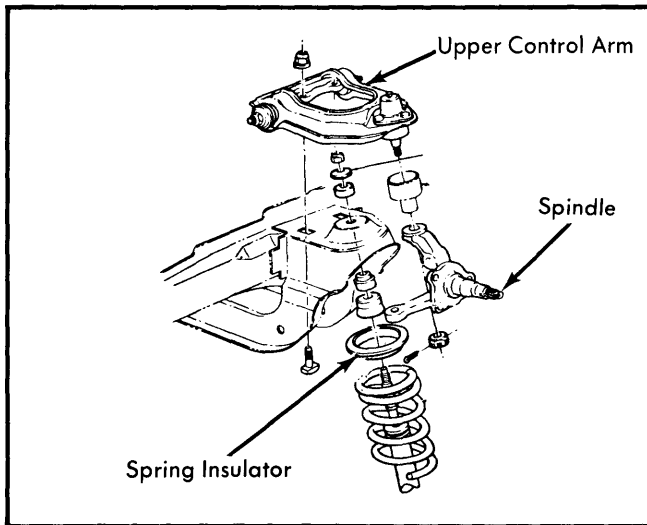

**Fig. 5 Exploded View of Mustang, Pinto & Bobcat Upper Control Arm Assembly**

**Installation (Pinto, Bobcat & Mustang)** — Slide shaft into upper control arm. Install shaft locator on shaft to keep shaft from turning. Position replacer adapter, "C" frame assembly, and bushing on end of shaft and install the bushing. Repeat procedure for other bushing.

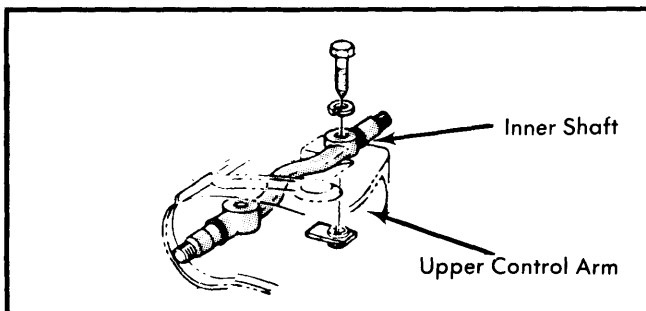

**Fig. 6 Exploded View of Upper Control Arm Inner Shaft**

**Removal (All Other Vehicles)** — Remove nuts and washers from both ends of upper control arm inner shaft. Install suitable tool (T65P-3044-A1) on inner shaft and place suitable tool (T65P-3044-A3) inside upper arm around inner shaft. Position assembly in press and remove lower bushing. Remove bushing from inner shaft. Repeat procedure to remove other two bushings.

**Installation (All Other Vehicles)** — Using tool as shown in illustration, position shaft and bushings to upper arm, then install bushings and inner shaft in upper arm. Install a washer and new nut on each end of inner shaft.

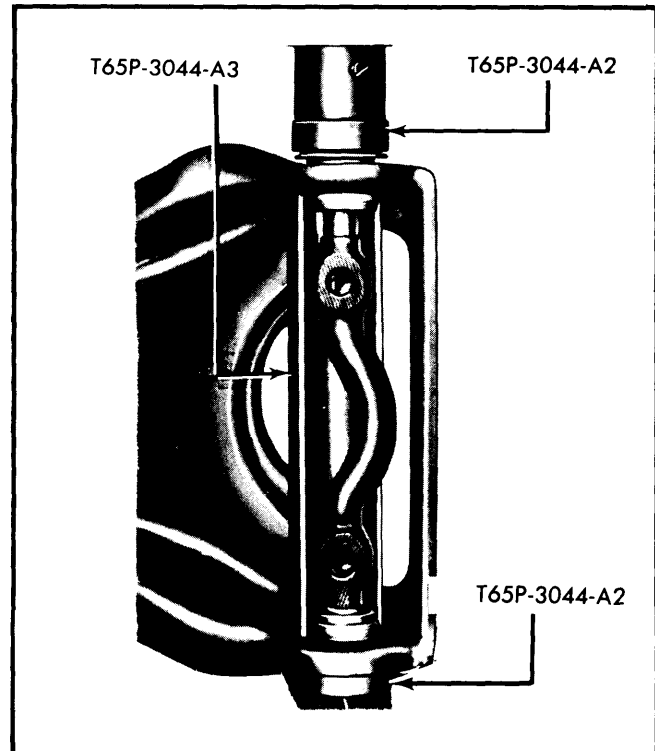

**Fig. 7 Installing Upper Control Arm Bushing (All Exc. Pinto, Bobcat & Mustang)**

### FRONT WHEEL SPINDLE

**Removal** — 1) Raise vehicle and position on safety stands. Remove wheel and hub. On vehicles with drum brakes, remove brake backing plate and support with wire to prevent damage to brake hose. On vehicles with disc brakes, remove caliper shield attaching bolts, then remove shield. Disconnect spindle connecting rod end from spindle arm using a suitable tool (3290-C).

2) Remove cotter pins from both ball joint stud nuts, then loosen nuts one or two turns. **CAUTION** — Do not remove nuts from studs at this time. Position ball joint remover tool between upper and lower ball joint studs. **NOTE** — Tool should seat firmly against ends of both studs and not against stud nuts.

3) Turn tool with a wrench until tool places studs under considerable tension. With a hammer hit the spindle near studs to break them loose in spindle. **NOTE** — Do not loosen studs with tool pressure only. Position a floor jack under the lower arm. Remove upper and lower ball joint stud nuts, lower jack and remove spindle.

**Installation** — To install, reverse removal procedure. If spindle is being replaced because of accident damage, check wheel alignment.

# Front Suspension

## FORD MOTOR CO. ENCLOSED SPRING (Cont.)

### TIGHTENING SPECIFICATIONS

#### Pinto, Bobcat & Mustang

Application	Ft. Lbs.
Lower Arm-to-Crossmember .....	95-120
Upper Arm-to-Frame .....	95-120
Stabilizer Bar-to-Lower Arm .....	10-18
Ball Joint-to-Spindle .....	①75-90
Strut-to-Lower Arm .....	40-60
Stabilizer Bar-to-Frame .....	14-21
Shock Absorber	
Upper .....	22-30
Lower .....	60-80
Backing Plate-to-Spindle .....	20-35
Strut-to-Frame .....	70-80

#### All Other Models

Application	Ft. Lbs.
Lower Arm-to-Crossmember .....	95-110
Upper Arm-to-Frame .....	②120-140
Upper Arm Bumper .....	15-18
Stabilizer Bar-to-Lower Arm .....	6-12
Ball Joint-to-Spindle	
Lincoln	
Upper .....	①75-90
Lower .....	①105-120
All Other Models .....	①80-120
Strut-to-Lower Arm .....	80-115
Stabilizer Bar-to-Frame .....	14-26
Shock Absorber	
Upper .....	22-30
Lower .....	12-18
Caliper-to-Spindle	
LTD II, Thunderbird & Cougar .....	90-120
All Other Models	
Upper .....	110-140
Lower .....	90-120
Disc Brake Splash Shield .....	9-14
Strut-to-Frame .....	95-105

① — Torque to minimum specification, then tighten nut to align cotter pin slot.

② — On Ford and Mercury Police and Taxi models, tighten to 130-150 ft. lbs.