

Front Suspension

AMERICAN MOTORS – PACER

American Motors, Pacer

DESCRIPTION

Independent front suspension is used on all models. Each wheel is attached by means of a steering knuckle, upper and lower control arms and ball joint assembly. Front wheels are held in proper relation by linkage which attaches to steering knuckle. Inner end of lower control arm is attached to front crossmember by two pivot bolt-eccentric assemblies and outer end is connected to steering knuckle by a ball joint. Inner end of upper control arm is attached to crossmember by means of a cross-shaft and outer end is connected to steering knuckle by a ball joint. Coil springs are located between seats in crossmember and seats in lower control arms. Conventional type shock absorbers are located inside the coil springs. A rubber insulated stabilizer bar is optional on Pacer models.

ADJUSTMENT

CASTER & CAMBER

See *Caster and Camber Adjustments and Specifications in WHEEL ALIGNMENT Section.*

FRONT WHEEL BEARINGS

See *Wheel Bearing Adjustment and Specifications in WHEEL ALIGNMENT Section.*

BALL JOINT CHECKING

See *Ball Joint Checking in WHEEL ALIGNMENT Section.*

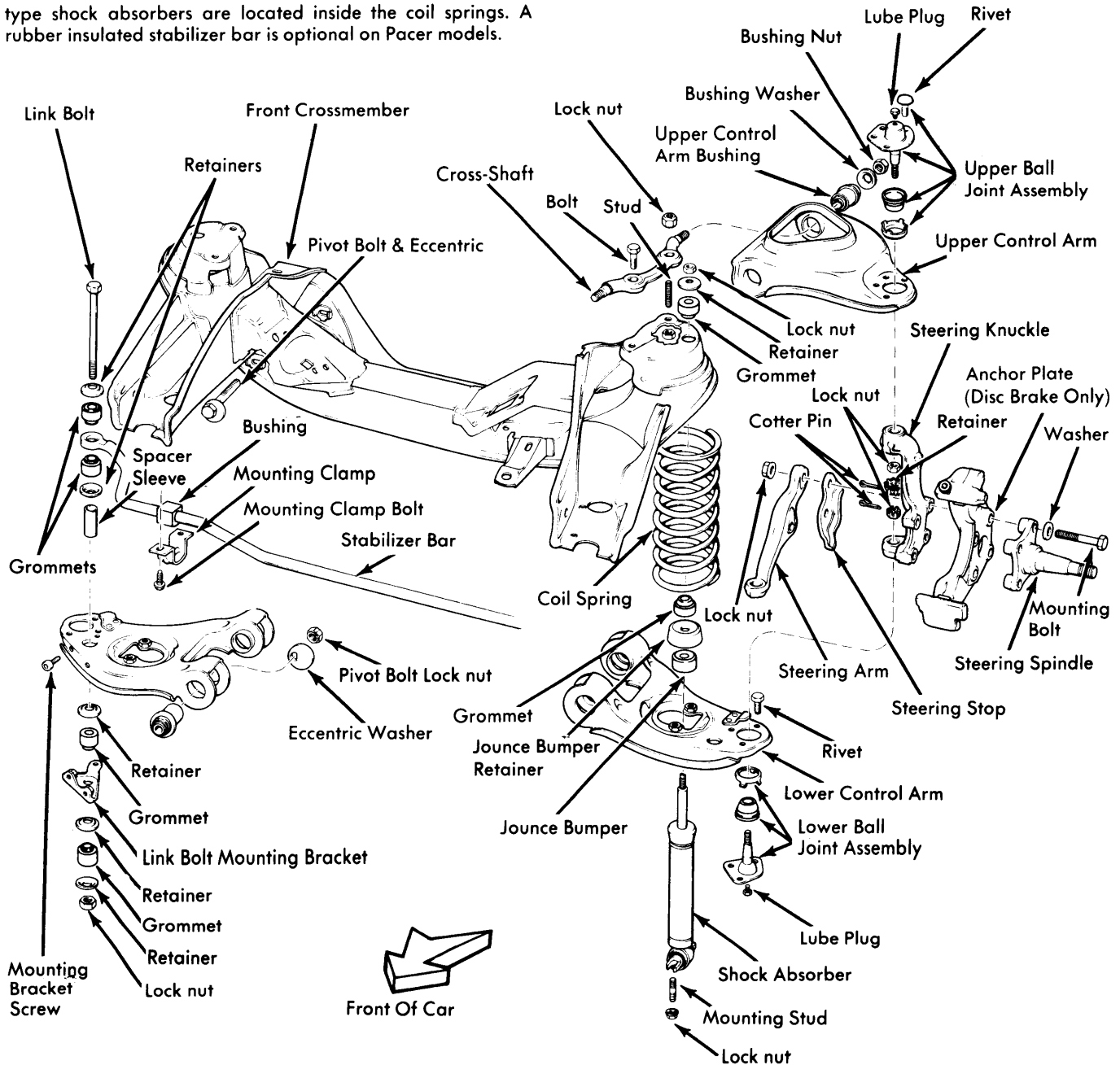

Fig. 1 Exploded View of Pacer Front Suspension Components

AMERICAN MOTORS – PACER (Cont.)

REMOVAL & INSTALLATION

COIL SPRING

Removal – Remove upper shock absorber mount, raise front of vehicle and remove lower shock absorber mount; remove shock absorber. Disconnect stabilizer bar at lower control arm (if equipped). Remove wheel, brake caliper and rotor. Remove bolts attaching steering arm to knuckle and move arm aside. Install suitable coil spring compressor tool (J-25581) and compress spring. Remove cotter pin and nut from lower ball joint stud and loosen ball joint from steering knuckle using suitable tool (J-9656). Remove ball joint from knuckle and move steering knuckle assembly aside. Move lower control arm aside, release spring compressor tool and remove tool and coil spring.

Installation – 1) Position upper end of spring in seat of front crossmember.

NOTE – Top coil of spring is flat.

2) Align cut-off end of coil with formed shoulder in spring seat and use floor jack or stand to support spring until spring compressor tool is installed. Install spring compressor tool and compress spring.

3) Insert lower control arm ball joint stud in steering knuckle and install and tighten retaining nut. Reinstall steering arm on steering knuckle and loosen spring compressor until bottom of spring is about $\frac{1}{2}$ " from control arm spring seat.

4) Pry inward on spring compressor to align bottom coil with seat in control arm. When spring and seat are aligned, release compressor tool and seat spring in control arm, remove compressor tool.

NOTE – Be sure cut-off end of coil butts against formed shoulder in control arm spring seat.

5) Reinstall shock absorber lower mount and stabilizer bar (if equipped). Install wheel, brake caliper and rotor. Lower vehicle and install upper shock absorber mount. Be sure locating shoulder on shock absorber grommet seats in hole in crossmember.

UPPER CONTROL ARM

Removal – Raise and support front of vehicle. Remove wheel. Remove retaining nut and lock nut from upper ball joint stud and loosen stud from steering knuckle using suitable tool (J-9656). Support lower control arm and knuckle assembly with floor jack and disengage stud from steering knuckle. Remove lock nuts securing cross-shaft to crossmember and remove upper control arm assembly.

Bushing Service – Remove bushing nuts and washers from cross-shaft. Place suitable "U" washer (J-23473-11) on upper control arm cross-shaft and position bushing receiver tool (J-23473-10) over large end of bushing and install "C" clamp tool (J-22269-01) over "U" washer and receiver. Tighten tool to remove bushing and repeat procedure for opposite bushing and cross-shaft. To install new bushings, position cross-shaft in control arm and install first bushing onto shaft and into control arm. Using bushing receiver tool and suitable bushing installer tool (J-23473-13), along with "C" clamp tool, press

bushing into control arm. Repeat procedure for other bushing and install bushing washers with dished side facing bushing. Install and partially tighten nuts.

Installation – Position upper control arm assembly on crossmember and studs, install and tighten lock nuts. Insert upper ball joint stud in steering knuckle. Raise lower control arm with floor jack to ease installation and install lock nut on upper ball joint stud. Tighten nut and install retainer and cotter pin. Do not loosen nut to align slots in nut with hole in ball stud. Install wheel and lower vehicle. Tighten cross-shaft bushing nuts.

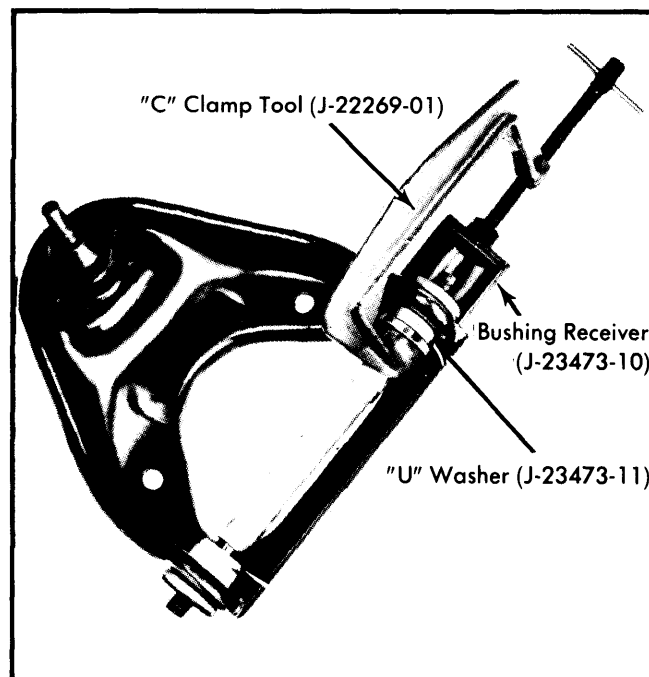

Fig. 2 Installation of Upper Control Arm Bushing Removal Tools

LOWER CONTROL ARM

Removal – Remove coil spring. Remove two pivot bolts that attach lower control arm to front crossmember and remove control arm.

Bushing Service – 1) To remove front (small) bushing, install suitable spacer tools J-23473-9 & J-23473-12 (or equivalent) in lower control arm.

CAUTION – Do not attempt to remove bushings without using spacer tools to avoid damaging control arm.

2) Install suitable bushing receiver J-23473-7 on bolt J-23473-6 and insert bolt through bushing sleeve.

NOTE – Insert threaded end of bolt through front bushing sleeve from outer end of lower control arm only.

3) Install remover washer tool J-23473-8 on threaded end of bolt followed by thrust bearing and nut (parts of tool J-23473-6). Tighten nut to press front bushing out of control arm.

Front Suspension

AMERICAN MOTORS – PACER (Cont.)

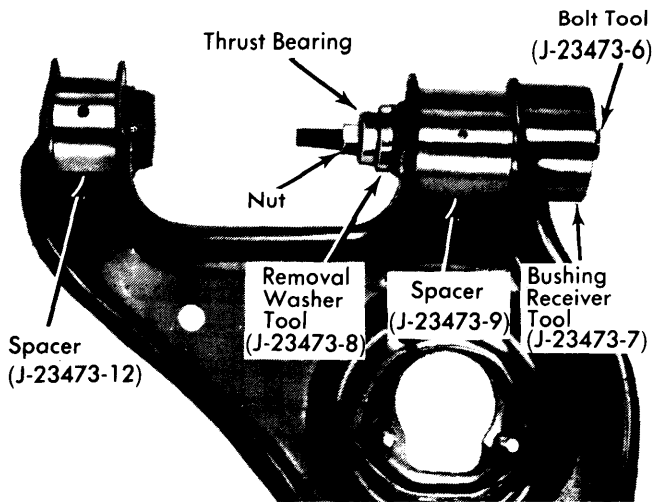

Fig. 3 Installation of Lower Control Arm Bushing Removal Tools

4) To remove rear (large) bushing, install bushing receiver tool on bolt and insert bolt through bushing sleeve.

NOTE – Insert threaded end of bolt through bushing sleeve from outer end of lower control arm only.

5) Install remover washer tool on threaded end of bolt followed by thrust bearing and nut. Tighten nut to press rear bushing out of lower control arm.

6) To install rear bushing, place bushing in control arm with flanged end of bushing facing away from control arm. Install bushing installer tool (J-23473-13) on bolt and insert bolt through bushing sleeve. Install bushing receiver tool on threaded end of bolt followed by thrust washer and nut. Tighten nut to press rear bushing into lower control arm. To install front bushing, follow above procedure only use bushing installer tool (J-23473-3). Remove tools and spacers from lower control arm.

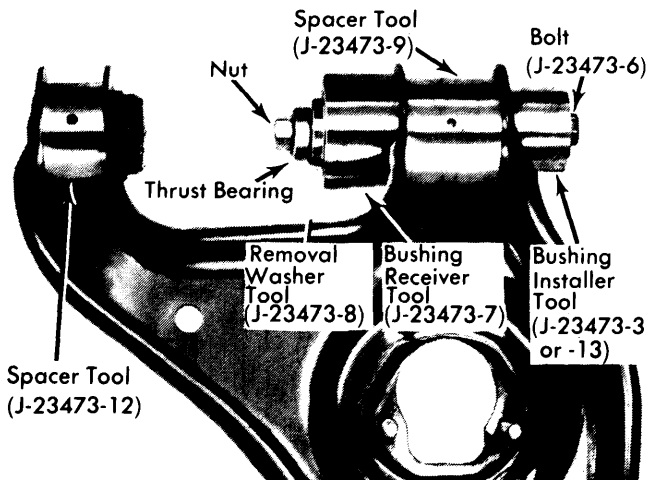

Fig. 4 Positioning of Lower Control Arm Bushing Installation Tools

Installation – Position lower control arm in crossmember and install pivot bolts and lock nuts. Tighten lock nuts securely but not completely. Reinstall coil spring and lower vehicle. Tighten lower control arm pivot bolts and check wheel alignment.

STEERING KNUCKLE

Removal – Raise and support front of vehicle. Remove wheel, brake caliper and rotor. Remove bolts securing steering arm, stop, spindle and support plate assembly to steering knuckle and remove components. Disconnect stabilizer bar from lower control arm (if equipped). Support lower control arm with floor jack and remove retaining nuts from upper and lower ball joint studs. Using suitable tool (J-9656) loosen ball joints from steering knuckle, disengage studs from knuckle and remove knuckle.

Installation – To install, reverse removal procedure and check wheel alignment.

UPPER CONTROL ARM BALL JOINTS

Removal – Raise and support front of vehicle. Remove wheel and support lower control arm with floor jack. Raise control arm about 1". Remove retaining nut from ball joint stud. Thread ball joint stud remover tool (J-9656) onto stud and lower floor jack slightly. Strike tool with hammer to loosen stud in knuckle. Grind or chisel heads from rivets attaching ball joints to upper control arm and remove rivets with punch. Remove tool from stud and remove ball joint assembly.

Installation – Reverse removal procedures and tighten all nuts and bolts while noting following: Use bolts supplied with new ball joint to attach assembly to control arm. Check wheel alignment.

LOWER CONTROL ARM BALL JOINTS

Removal – Raise and support front of vehicle. Remove wheel, brake caliper and rotor. Remove two bolts that attach steering arm to steering knuckle and move arm aside. Disconnect stabilizer bar from lower control arm (if equipped). Support lower control arm with floor jack and remove retaining nut from ball joint stud. Thread ball joint removal tool (J-9656) onto ball joint stud and release floor jack. Strike tool with hammer to loosen stud in knuckle. Support lower control arm with jack and remove tool. Disengage stud from knuckle. Move steering knuckle assembly aside and grind or chisel heads from rivets which attach ball joint to control arm. Remove rivets with a punch and remove ball joint assembly.

Installation – Reverse removal procedures and tighten all nuts and bolts while noting following: Use bolts supplied with new ball joint to attach assembly to control arm. Check wheel alignment.

TIGHTENING SPECIFICATIONS

Application	Ft. Lbs.
Ball Joint Stud Nut.....	75
Support Plate-to-Steering Knuckle	85
Shock Absorber Lock Nut	
Upper	8
Lower	20
Lower Control Arm Pivot Bolt Nut	110
Stabilizer Bar-to-Control Arm	7
Upper Control Arm Cross-Shaft	
Bushing Nut	60
Retaining Nut	80