

BENDIX/DELCO-MORAINE DUAL PISTON MASTER CYLINDER

American Motors
Chrysler Corp.
Ford Motor Co.
General Motors

DESCRIPTION

NOTE — All General Motors sub-compact (H and T body styles) models use master cylinders with a common reservoir for both pistons. All other makes and models use master cylinders with two reservoirs, one for each piston.

Master cylinder is a single cylinder with front and rear pistons. Unit can have a divided reservoir or a common reservoir. Rear piston is operated by a pushrod. Front piston is operated by rear piston. In a separated reservoir, the larger reservoir feeds the disc brakes. This is because the pistons used on disc brakes are larger than wheel cylinders used on drum brakes. A residual pressure valve is located in the master cylinder under outlet seat for drum brakes. This keeps a small amount of pressure in drum brake circuit. Disc brake outlet does not have a residual pressure valve. **NOTE** — Disc brakes must not have any residual pressure or they will lock up.

On some master cylinders a stop screw is screwed in from outside of cylinder. This stop screw limits return stroke of front piston. Some master cylinders have one outlet on bottom and one on the side. A bleeder screw on these master cylinders allows trapped air to be released. **NOTE** — Chrysler models do not use a residual valve for rear drum brakes.

REMOVAL & INSTALLATION

Removal — On power brake systems disconnect hydraulic lines, remove cylinder mounting nuts and remove cylinder. Do not remove power unit. On manual brake systems disconnect hydraulic lines and pushrod at brake pedal under dash, then remove cylinder mounting nuts and remove cylinder.

Installation — 1) Master cylinder must be bled before bleeding entire system. Master cylinder bleeding may be done on vehicle. Preferred method is to bleed master cylinder on bench. If master cylinder has a bleed screw, bench method should still be used. When master cylinder is installed on car, use bleed screw as a final check for trapped air.

2) Place master cylinder level in a vise. Attach bleeding tubes to cylinder. Fill reservoirs with fluid so that ends of tubes are covered (see Fig. 1). Tubes attached to disc brake outlets must have residual pressure valves installed over ends. This will keep tubes from siphoning.

3) Stroke piston in bore with a wooden stick or dowel until bubbles no longer appear at ends of tubes. Remove tubes and plug the master cylinder disc brake outlets to keep fluid from draining.

4) Install master cylinder on car, reversing removal procedure. Bleed master cylinder bleed screw first, if used, and then bleed remainder of system. See "Hydraulic Brake Bleeding" in this section.

5) Check master cylinder compensating ports by pumping brake pedal several times, ending with pedal held down. Remove master cylinder cover and slowly release pedal. Fluid

should squirt up in each reservoir from the compensating ports.

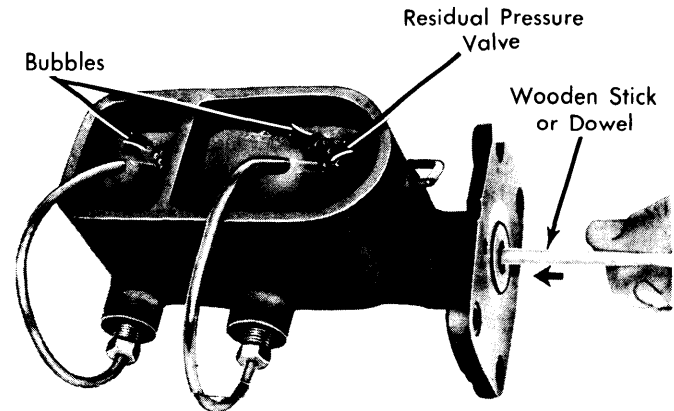

Fig. 1 Bleeding Master Cylinder (Bleeding Tubes Installed)

6) If fluid does not squirt in each reservoir, port is plugged or push rod is too long. Check for plugged port. **NOTE** — Do not use wire to check ports. Wire may make a burr on port or damage cup. If port is not plugged, adjust manual brake push rod at clevis under dash. On power brakes, see Push Rod Adjustment under POWER BRAKE UNITS in this section.

7) Pushrod should have a slight amount of play when in relaxed position, so that both master cylinder pistons will return to their stops when brakes are off. **CAUTION** — Do not use wire to check compensating ports. Wire may make a burr on port or damage cup.

OVERHAUL

Disassembly — 1) Place master cylinder in a vise. Remove reservoir cover and diaphragm type gasket. Depress piston and remove stop screw. **NOTE** — On all Cadillac models, except Seville, stop screw is not used.

2) Remove lock ring from groove in end of bore or retainer and screw. Remove rear (primary) piston assembly. **CAUTION** — Do not disassemble rear piston assembly or change adjustment of screw.

3) Remove front (secondary) piston with air pressure. If air pressure does not work, use wire hook to pull piston out end of cylinder. Remove front piston spring if it did not come out with piston. Remove splash seal and retainer outside rear of cylinder, if they are used.

4) Remove tube seats to gain access to check valves. Use self-tapping removal kit if supplied in repair kit. If removal kit not available, use one of these methods. Thread a short screw into seat. Pry screw and seat out with a screwdriver. Another method is to drill a $1\frac{3}{4}$ " hole through each seat. Then tap hole with a $\frac{1}{4}$ -20 tap. Screw a tubing nut into outlet. Then insert a $\frac{1}{4}$ -20 machine screw (with washer) through nut and into tube

Brake Systems

BENDIX/DELCO-MORAINE DUAL PISTON MASTER CYLINDER (Cont.)

seat. Hold screw from turning. Unscrew the tubing nut to remove seat. Remove check valve and spring from drum brake outlet. **NOTE** — Ford does not recommend tube seat removal.

Inspection — Inspect cylinder bore for scoring or corrosion. Staining which has not pitted or roughened the surface can be removed with crocus cloth. Move cloth in circular manner. Never polish cylinder with lengthwise strokes. If cylinder is scored, corroded, or pitted, American Motors and General Motors recommend replacing the cylinder. Chrysler Corporation permits honing if diameter of bore is not increased beyond .002" oversize. Ford Motor Company permits honing if bore diameter increase is not over .003".

Reassembly — 1) Put check valve spring in drum brake outlet. **CAUTION** — Check valve in disc brake outlet will cause disc brakes to lock up. Put check valve on top of spring and insert tube seat in outlet against valve. Use a spare tube nut, and screw nut into outlet to bottom tube seat. Remove nut and inspect for burrs or shavings caused by installing seat.

2) Install new secondary cups on rear of front (secondary) piston. Place cup lips facing away from each other. Some front pistons use a cup in rear grooves and an "O" ring in second groove from rear. Place cup so lip faces forward and back of cup is against protector washer. **NOTE** — Protector washer may be permanently attached to cup.

3) If it is necessary to disassemble rear (primary) piston for replacement of parts see "Primary Piston Assembly" illustration.

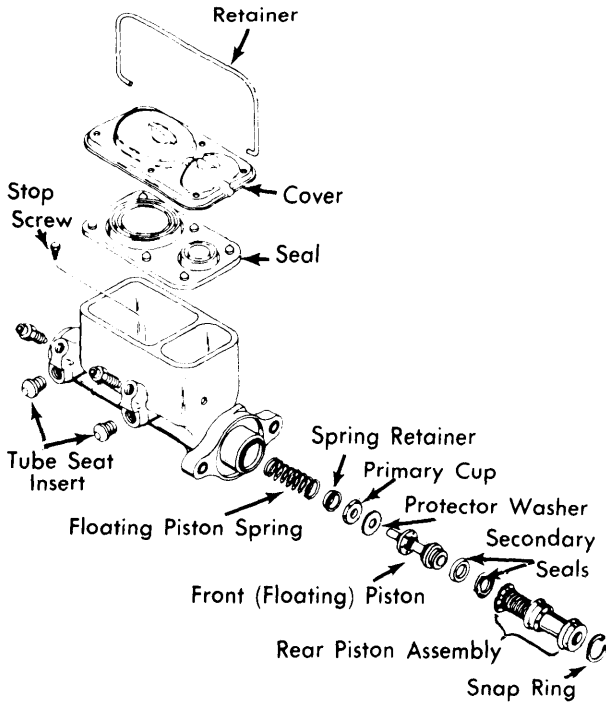

Fig. 2 Typical Delco-Moraine Dual Reservoir Master Cylinder (General Motors Shown)

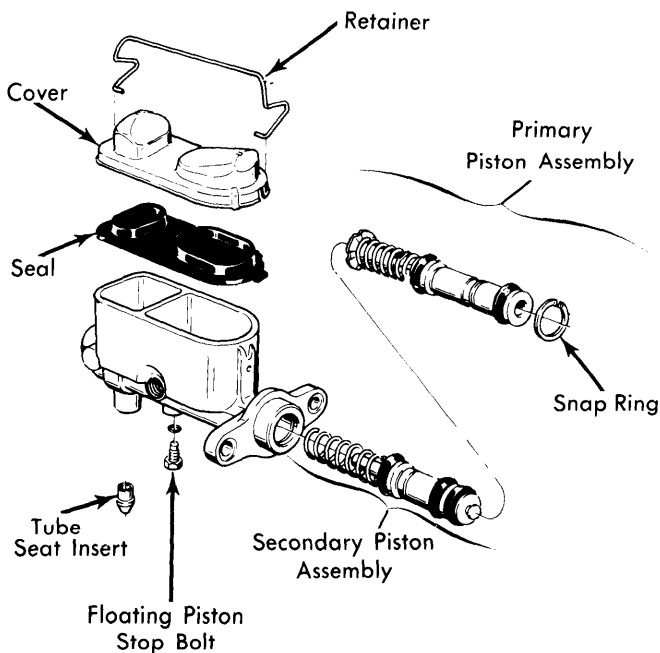

Fig. 3 Bendix Master Cylinder (Ford Motor Co. Shown)

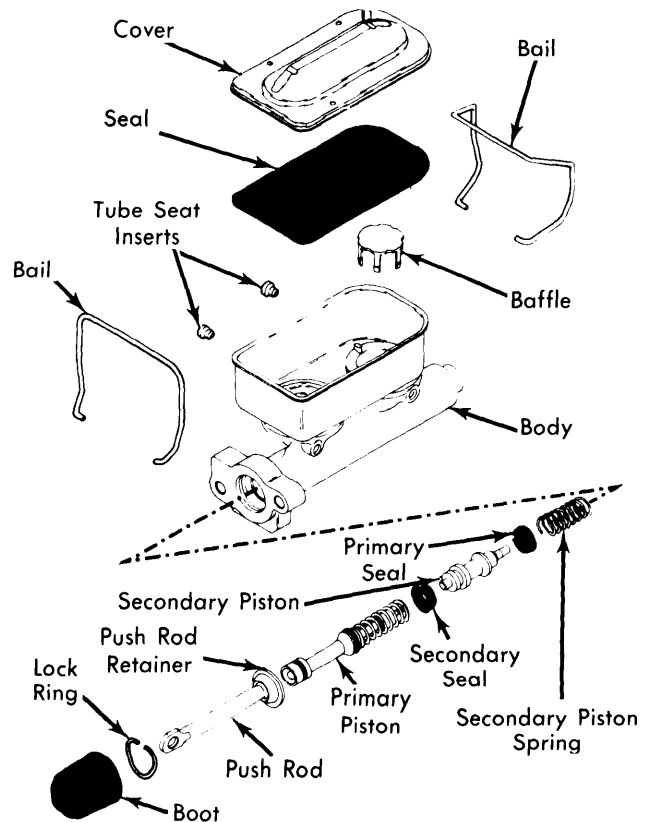

Fig. 4 Common Reservoir Manual Brake Master Cylinder (General Motors Shown)

BENDIX/DELCO-MORAINE DUAL PISTON MASTER CYLINDER (Cont.)

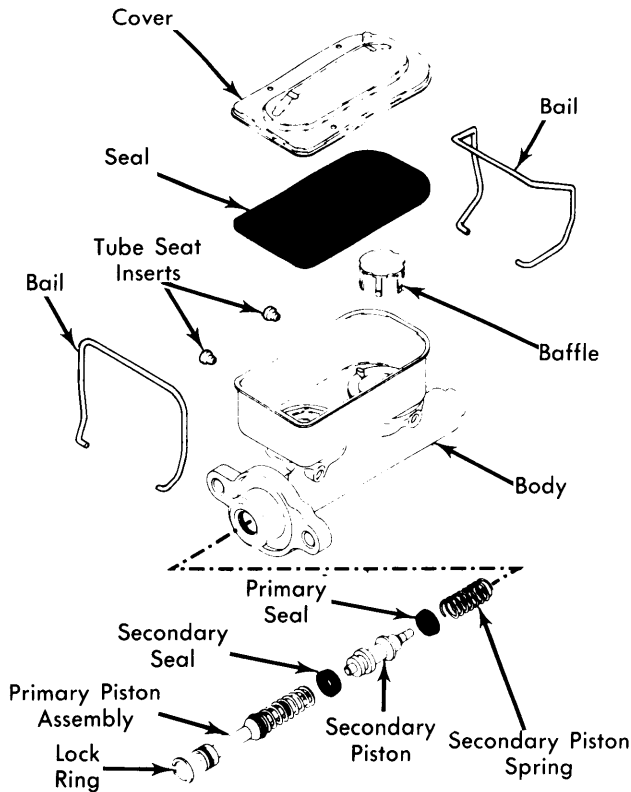

Fig. 5 Common Reservoir Power Brake Master Cylinder (General Motors Shown)

4) Coat bore of cylinder and all cups with brake fluid. Place spring retainer on end of front spring. Place spring on end of front piston so that retainer is seated inside cup. Hold open end of master cylinder down. Push front spring and piston up into bore until spring seats against end of cylinder.

5) Hold master cylinder with open end up. Insert rear piston assembly with spring end going in first. Install lock ring in groove, or screw and retainer if used. Push rear piston into bore. Install stop screw and "O" ring if used. **NOTE** - Stop screw is a special screw. Do not use any other type as a substitute. **CAUTION** - On all Cadillac models (except Seville) a stop screw is not used even though a drilled and tapped hole may be provided. If stop screw is installed, damage to master cylinder piston or seal will result.

6) Install master cylinder cover and gasket. Place beaded side of gasket against master cylinder. On manual brake systems, assemble pushrod through retainer if used. Push retainer over end of master cylinder. Install a new boot over pushrod and press boot down over pushrod retainer.

TIGHTENING SPECIFICATIONS

Application	Ft. Lbs.
American Motors	
Master Cylinder-to-Firewall	30
Master Cylinder-to-Power Unit	30
Brake Line-to-Master Cylinder	13
Chrysler Corp.	
Master Cylinder-to-Firewall	17
Master Cylinder-to-Power Unit	7-17
Brake Line-to-Master Cylinder	
3/8-7/16"	7-13
1/2-9/16"	10-15
Ford Motor Co.	
Master Cylinder-to-Firewall	13-25
Master Cylinder-to-Power Unit	13-25
Brake Line-to-Master Cylinder	10-18
General Motors	
Master Cylinder-to-Firewall	⓪24
Master Cylinder-to-Power Unit	⓪24
Brake Line-to-Master Cylinder	13

⓪ - Torque to 13 ft. lbs. on Chevette models.

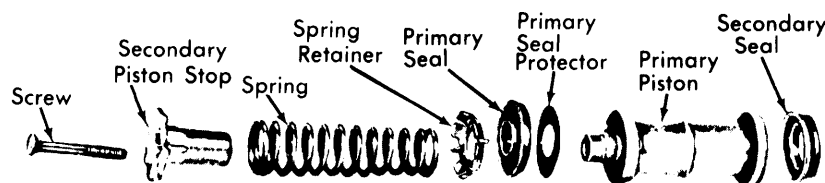

Fig. 6 Exploded View of Primary Piston Assembly

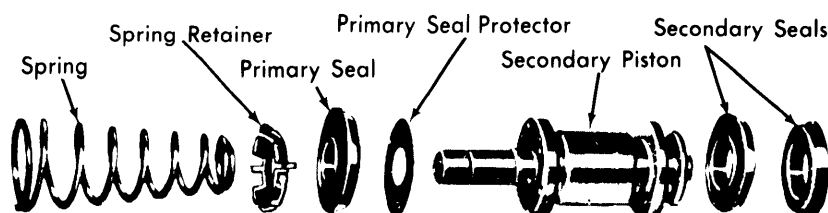

Fig. 7 Exploded View of Secondary Piston Assembly