

BENDIX SINGLE DIAPHRAGM

American Motors
Chevrolet
Chrysler Corp.
Ford Motor Co.

DESCRIPTION

Vacuum suspended, self-contained, vacuum-hydraulic unit which utilizes engine manifold vacuum and atmospheric pressure to provide its power. Vacuum power unit contains power piston assembly, which houses control valve, reaction mechanism, and return spring. Control valve consists of air valve, floating control valve assembly, and push rod. Reaction mechanism consists of reaction plate and levers. A vacuum check valve is mounted in front housing for connection to vacuum source.

REMOVAL & INSTALLATION

Removal — Disconnect vacuum line from power unit. On Chevrolet, remove hydraulic lines from master cylinder. On all others, detach master cylinder from power unit. **NOTE** — *It is not necessary to disconnect hydraulic lines.* Move master cylinder aside. Detach push rod from brake pedal (under instrument panel). On Ford models, disconnect stop light switch wiring from switch, remove hairpin retainer, slide stop light switch from pedal just enough for outer hole to clear pin, then remove switch from pin and push rod. Slide push rod off brake pedal pin. On all cars, unbolt power unit from dash panel. On Dodge and Plymouth with linkage type power unit, remove lower pivot retaining bolt.

Installation — Reverse removal procedure and install all related parts noting the following: Before attaching master cylinder, check push rod for proper length. See *Push Rod Adjustment*. Check that all lines are secure and that no fluid leakage is present. Bleed system.

OVERHAUL

NOTE — *American Motors, Chrysler Corp., and Ford Motor Co. do not recommend overhaul of this power brake unit.*

Disassembly — 1) Scribe mark housings for reassembly. Remove master cylinder from power unit and set aside. Remove front housing seal and piston rod. Attach assembly to suitable holding fixture (J-22805). **CAUTION** — *Ensure proper tool alignment to avoid damage to check valve in front housing.* Loosen lock nut and remove push rod clevis and lock nut, if equipped. Remove dust boot retainer, dust boot, and silencer from diaphragm plate extension. Partially straighten four deepest tabs on rear housing. Place suitable wrench (J-9504) over studs on rear housing and attach with nuts and washers. Press down on wrench and rotate rear housing clockwise to separate. **CAUTION** — *Housings are under internal spring tension.* Remove wrench from housing.

2) Remove air filter from diaphragm plate extension. Remove diaphragm from groove in diaphragm plate. **CAUTION** — *Protect and handle diaphragm carefully.* Hold diaphragm plate so that push rod is in horizontal position. Depress rod slightly and rotate piston until air valve lock falls from diaphragm plate hub. Remove reaction disc from diaphragm plate bore (use push rod, or suitable tool, to push disc from seat). **CAUTION** — *Do not chip diaphragm plate.*

3) Remove rear shell bearing seal with punch or screwdriver. **CAUTION** — *Remove seal only if new one is available. Do not reuse seal if it has been removed.* Remove vacuum check valve and grommet.

Cleaning & Inspection — Use only denatured alcohol or clean brake fluid to clean all metal, plastic, and rubber parts. Blow out all passages, orifices, and valve holes with clean, dry air, and air dry all parts. Slight rust on inside of housing can be polished with crocus cloth or fine emery cloth. There should be no cuts, nicks, or distortion of any rubber part. If in doubt about condition of any part, replace the part.

Reassembly — 1) Install vacuum check valve grommet (beveled edge on inside), dip check valve in clean, denatured alcohol and install. Install suitable holding fixture (J-22805) on front housing. Install new rear housing seal in center hole, using suitable tool (J-22677) to seat seal in recess (tool bottoms against housing when seal is in place).

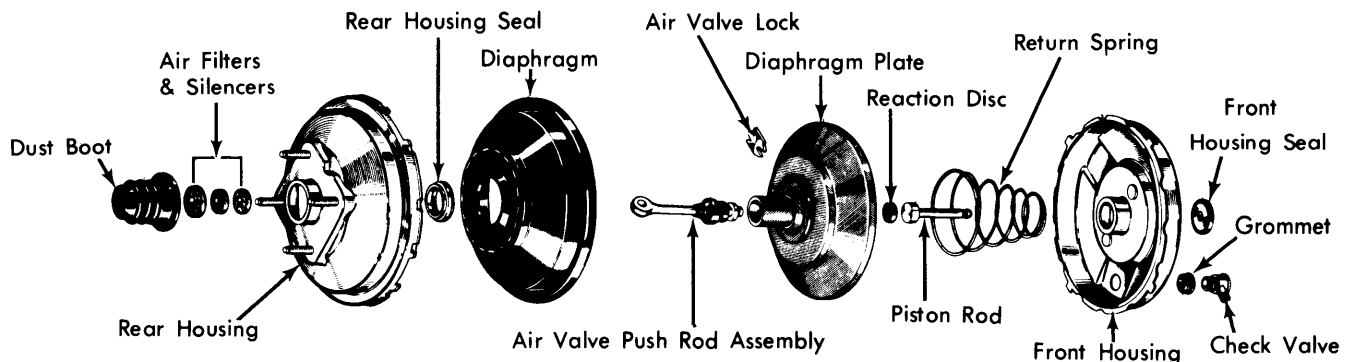

Fig. 1 Exploded View of Bendix Single Diaphragm Assembly

Power Brake Units

BENDIX SINGLE DIAPHRAGM (Cont.)

2) Assemble diaphragm plate assembly as follows: Lubricate outer diameter of diaphragm plate and extension, valve, and plunger bearing surfaces, and outer edge of valve poppet. Install valve and rod into diaphragm plate extension. Depress pushrod slightly and install air valve lock (lock must index and retain air valve). Install rolling diaphragm in diaphragm plate hub groove. Lubricate reaction disc and install disc (use master cylinder push rod to seat disc in diaphragm plate bore). **NOTE** — If disc is not fully seated, push rod height will be incorrect.

3) Lubricate inside of bearing seal and diaphragm bead contact-surface of rear shell. Install diaphragm plate assembly in rear housing. Place air filter element over push rod and into diaphragm plate extension. Install filter retainer. With holding-fixture in place, position suitable wrench (J-9504) over studs on rear housing and position front and rear housings together. Press down on wrench and rotate counterclockwise (rear housing) to lock housings. Align scribe marks. Rebend tabs on rear housing (if tabs are cracked or broken, housing must be replaced). Remove wrench from housing. Install air silencers over push rod end. Install push rod boot and boot retainer. On clevis-type push rods, install lock nut and push rod clevis. Lightly lubricate piston rod (except rounded end). Guide rod into center bore until fully seated against reaction disc. Install front housing seal (in same manner as rear seal). Attach master cylinder.

PUSH ROD ADJUSTMENT

1) Push rod height check or adjustment is required if master cylinder and power unit are separated, or if push rod is replaced or transferred from one unit to another, or if misadjustment is diagnosed as cause of braking problems.

NOTE — Chrysler Corp., and American Motors units use non-adjustable or factory adjusted push rods. Do not attempt to adjust this type push rod.

2) Ford Motor Co. Push rod gauge may be made according to dimensions shown in Fig. 3. Place gauge over push rod and adjust push rod nut to provide a slight tension (approximately five pounds) against gauge.

3) Chevrolet push rod height checking must be done with special "GO-NO GO" gauge (tool no. J22647). Place power brake unit in a vise with push rod up and remove housing seal. Depress push rod with a 40-50 pound force to make sure it is seated properly. Place gauge over push rod, make sure gauge does not touch studs. Push rod should not touch short tab and should always touch long tab. If push rod is too long or too short, an adjustable push rod must be used and adjusted to the correct length using the "GO-NO GO" gauge.

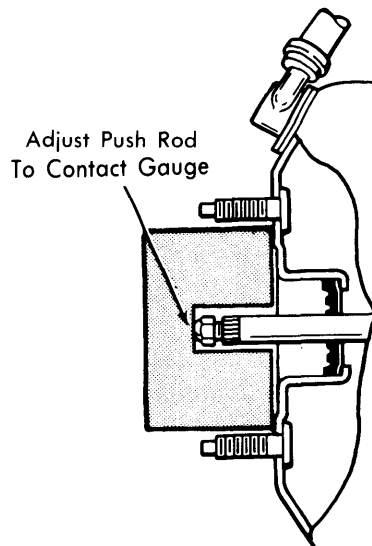

Fig. 2 Measuring Push Rod Height (Ford Motor Co.)

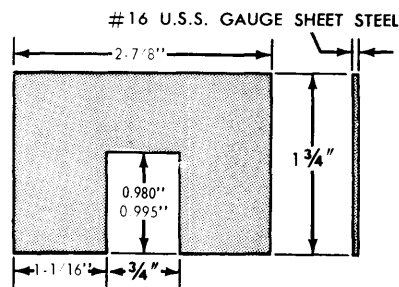

Fig. 3 Ford Push Rod Gauge Specifications

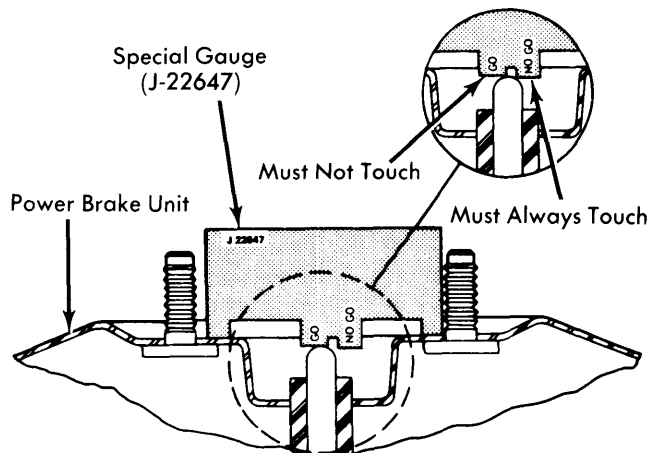

Fig. 4 Chevrolet Push Rod Gauging Method with Special "GO-NO GO" Gauge J-22647