

BENDIX HYDRO-BOOST

CADILLAC
Eldorado
FORD MOTOR CO.
Granada
Monarch
Mercury
Ford
Thunderbird
Lincoln
Mark V

DESCRIPTION

System utilizes power steering pump fluid pressure to operate booster. Assembly contains an open center spool valve which controls pump pressure magnitude during braking, a lever mechanism to control position of the valve, and a boost piston to provide force necessary to operate master cylinder. Unit also has a reserve system which stores sufficient fluid under pressure to provide at least two to three braking applications in case fluid flow from power steering pump is not available. Brakes can also be applied manually if reservoir system is depleted.

OPERATION

RELEASED POSITION (NO BRAKING)

In this position, spool valve return spring holds spool valve open. In open position, spool valve provides unrestricted fluid flow between power steering pump and power steering gear. Fluid pressure is blocked from entering boost pressure chamber by lands on spool valve. As fluid pressure increases with steering demand, it has no effect on boost pressure chamber. Boost pressure chamber is vented through spool valve, to pump return port, and back to power steering pump.

BRAKING POSITION

As brake pedal is depressed, it moves pedal rod and initiates movement of spool valve. This closes fluid return port to pump from boost chamber, and admits fluid into boost chamber from pressure port. Additional valve movement restricts flow between pump and steering gear, causing pump to increase fluid pressure to maintain flow rate to steering gear. As fluid pressure increases in boost chamber, it forces piston forward actuating master cylinder piston, resulting in brake application. If fluid pressure is required for steering while braking, pump pressure will rise and spool valve will shift in an open direction allowing more fluid to flow to steering gear.

RESERVE SYSTEM

1) System consists of a charging valve, accumulator valve, and a spring loaded accumulator (compressed gas accumulator on Ford Motor Co. vehicles). System is open to pressure port of booster unit. Charging valve has an orifice and ball check. Fluid from pump passes through orifice in valve, and if pressure exceeds pressure in accumulator, it unseats ball check valve and enters accumulator. Ball check valve prevents reverse flow when accumulator pressure is greater than pump pressure.

2) Accumulator valve is a poppet type valve held closed by pressure stored in accumulator. An actuator on spool valve sleeve opens accumulator valve when a stop with no pump pressure is made that requires use of reserve pressure. Fluid pressure can also enter accumulator from boost chamber through accumulator valve, when boost chamber pressure exceeds accumulator pressure. A pressure relief valve vents accumulator to pump return port when Pressure in accumulator exceeds approximately 1600 psi (1400 psi on Ford Motor Co. vehicles).

TESTING

NOTE— Hydro-Boost cannot cause noisy brakes, fading brake pedal, or pulling brakes. If one of these conditions exists, other components of brake system may be the cause.

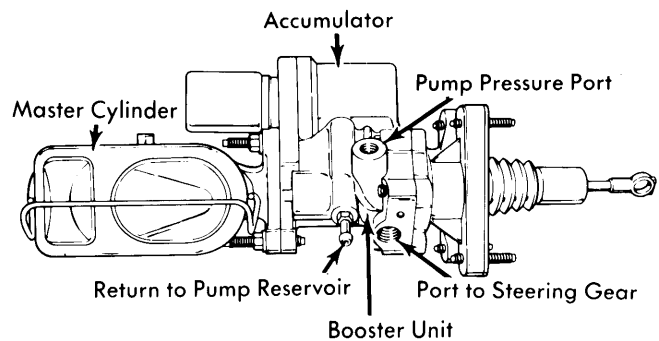

Fig. 1 Cadillac Hydro-Boost Power Brake Unit

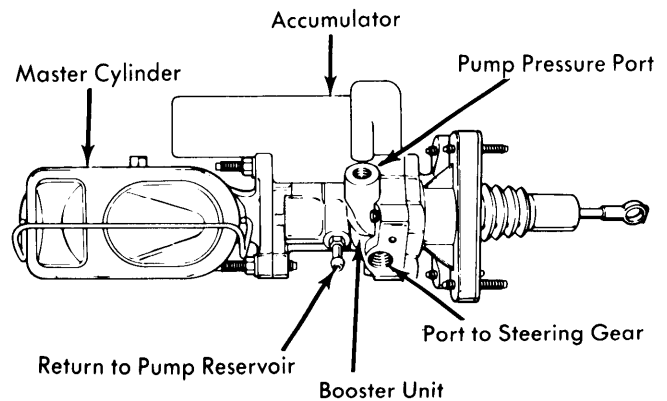

Fig. 2 Ford Motor Co. Hydro-Boost Power Brake Unit

PRELIMINARY CHECKS

Check fluid levels in master cylinder and power steering pump. Check power steering pump belt tension, and adjust if necessary. Inspect all power steering hoses for leaks or kinks. If fluid smells burned, check hoses or cooler for restrictions. Check and adjust engine idle speed. Check power steering hydraulic fluid for aeration (shown by bubbles in fluid), bleed system if necessary.

Power Brake Units

BENDIX HYDRO-BOOST (Cont.)

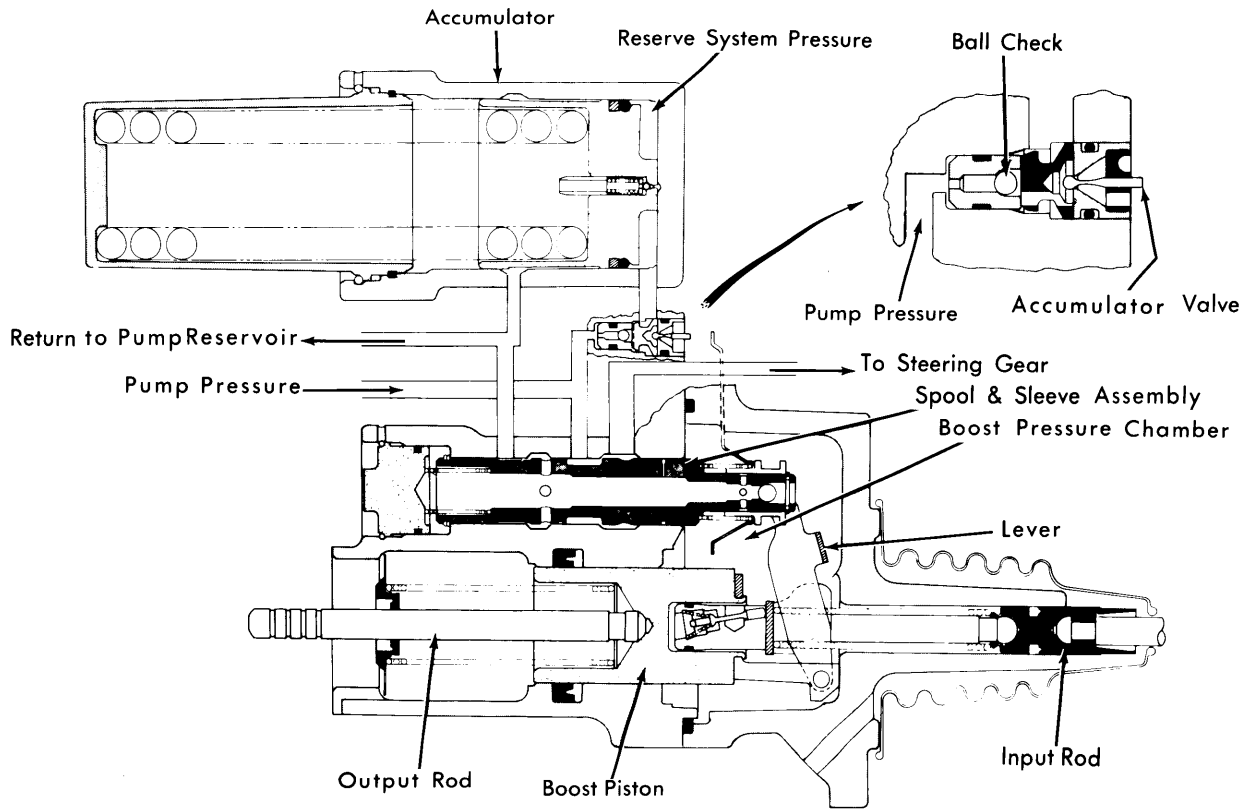

Fig. 3 Cadillac Hydro-Boost Hydraulic Circuits

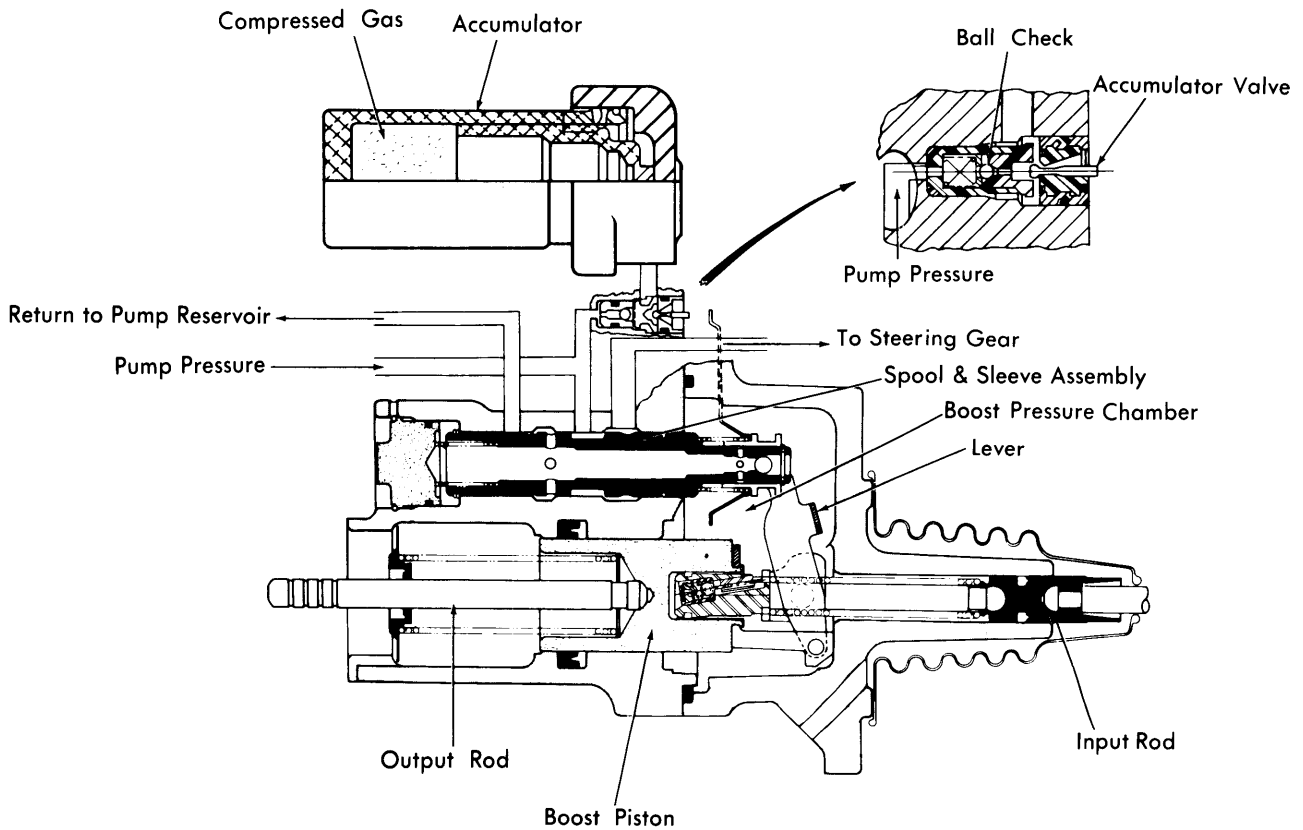

Fig. 4 Ford Motor Co. Hydro-Boost Hydraulic Circuits

BENDIX HYDRO-BOOST (Cont.)

NOTE — If problem cannot be found in preliminary steps, make following tests. If unit is found to be operating properly, check areas of brake system that might cause condition. See *Hydraulic Brake Trouble Shooting* in this section.

HYDRO-BOOST FUNCTIONAL TEST

Check hydraulic brake system for leaks or insufficient fluid in master cylinder reservoir. With transmission in Neutral, stop engine and apply brake pedal several times to deplete all accumulator reserve. Hold brake pedal depressed with medium pressure (approximately 25-35 lbs.) and start engine. If unit is operating correctly, brake pedal will fall slightly and then push back against foot. If no action is felt, hydraulic booster system is not operating.

ACCUMULATOR LEAKDOWN TEST

1) Start engine and operate at idle speed. Turn steering wheel to either stop and hold in this position for a maximum of five seconds. Return steering wheel to center position and turn off engine. Depress and release brake pedal. Repeat procedure until a hard pedal is obtained. There should be at least two power assisted brake applications with 20-25 lbs. applied to brake pedal.

2) Restart engine and let it idle. Turn steering wheel to either stop. There should be a light hissing sound as accumulator is charged. Hold steering wheel lightly against stop for a maximum of five seconds. Return steering wheel to center position and turn off engine. Wait one hour and apply brake pedal (DO NOT re-start engine). There should still be at least two power assisted brake applications at 20-25 lbs. pedal load before a hard pedal is encountered.

NOTE — If Hydro-Boost is not functioning, insure power steering system is operating normally before replacing Hydro-Boost unit.

REMOVAL & INSTALLATION

REMOVAL

NOTE — Before removing unit, discharge accumulator by making several brake applications until a hard pedal is obtained.

1) Working from inside vehicle below instrument panel, disconnect Hydro-Boost push rod from brake pedal assembly as follows: **NOTE** — On Cadillac vehicles there is no stop switch and pedal pin is removed after booster unit is removed from firewall. Disconnect stop light switch wires to connector, then remove hairpin retainer. Slide stop light switch off brake pedal pin just far enough for switch outer hole to clear pin, then remove switch from pin. Slide push rod and nylon bushing and washers off brake pedal pin.

2) Working under hood, remove two nuts which attach master cylinder to booster unit, then move master cylinder to one side of power unit without damaging brake lines. Disconnect pressure, steering gear and return lines from booster unit, then plug all lines and ports to prevent entry of dirt. Remove booster unit to dash panel attaching nuts, then remove assembly, sliding push rod link out from engine side of dash panel.

INSTALLATION

1) Mount booster unit to dash panel by inserting push rod and boot through hole in dash panel, then install and tighten attaching nuts. Install master cylinder on booster unit, then install and tighten attaching nuts. Remove plugs and connect fluid pressure, steering gear and return line fittings to booster unit.

2) Install inner nylon washer, booster unit push rod, and bushing on brake pedal pin. Position switch so that it straddles push rod with switch slot on pedal pin and switch outer hole just clearing pin. Slide switch completely onto pin and install nylon washer and hairpin retainer. Connect stop light switch wires to connector, then install wires in retaining clip.

3) Remove coil wire so that engine will not start. Fill power steering pump reservoir and, while engaging starter, apply brake pedal with a pumping action. Do not cycle steering wheel until all residual air has been purged from booster unit. Check fluid level, adjust as necessary. Install coil wire, start engine, cycle steering wheel and apply brake pedal with a pumping action. Check for fluid leaks.

NOTE — If a whine type noise develops following installation of power unit, fluid aeration may be suspected. Air must be removed from system using a suitable power steering pump air evacuator assembly.

OVERHAUL

NOTE — Ford Motor Co. does not recommend overhaul of this unit. If a problem is determined to be in booster unit, complete assembly must be replaced. Do not disassemble booster unit.

CAUTION — Care should be taken when handling front housing as accumulator contains a high rate spring in compression.

CAUTION — Power steering fluid and hydraulic brake fluid CANNOT be mixed. Do not allow power steering fluid to contact brake seals or hydraulic brake fluid to contact power steering seals as seal damage will result.

BRAKE-BOOSTER

Disassembly — 1) Using suitable holding fixture, mount booster assembly in a vise with pedal rod facing downward. Pump pedal rod four or five times to deplete accumulator pressure. Cut strap attaching accumulator cap to drip pan. Using suitable socket (J-25085) loosen Torx head bolts attaching front housing to rear cover. **NOTE** — Front housing is that part of booster assembly which includes accumulator. Rear cover is that part from which pedal rod extends.

2) With Torx bolts removed, carefully lift front housing leaving spool valve and power piston assembly attached to rear cover. Remove output rod and piston return spring from power piston assembly and spool valve spring from spool valve. Remove output rod retainer from front housing.

Power Brake Units

BENDIX HYDRO-BOOST (Cont.)

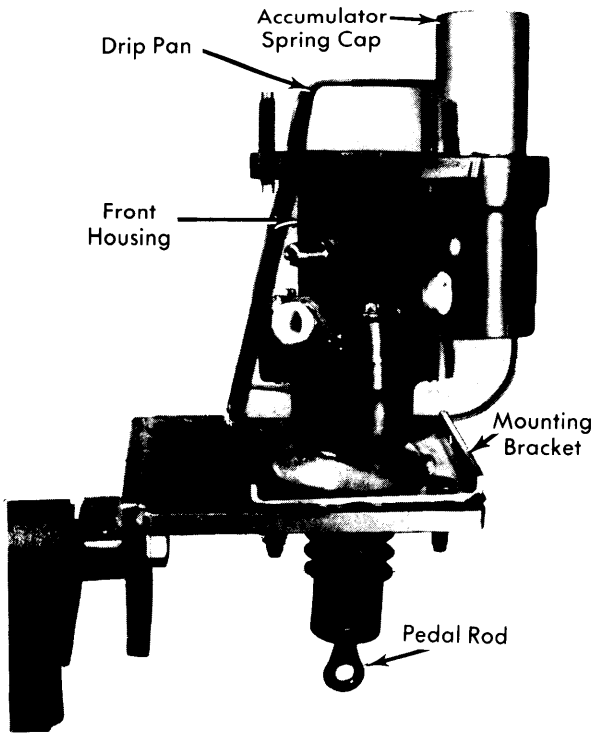

Fig. 5 Bracket for Booster Disassembly

3) Remove spool valve by rotating it out of lever arm. Remove and discard seal from rear cover. Remove power piston seal from bore and discard it. Inspect spool valve and power piston for wear or scratches, replace if necessary. To remove power piston use a pair of diagonals to cut off end of connecting pin. With a small punch push out pin and remove piston. Clean all parts with power steering fluid.

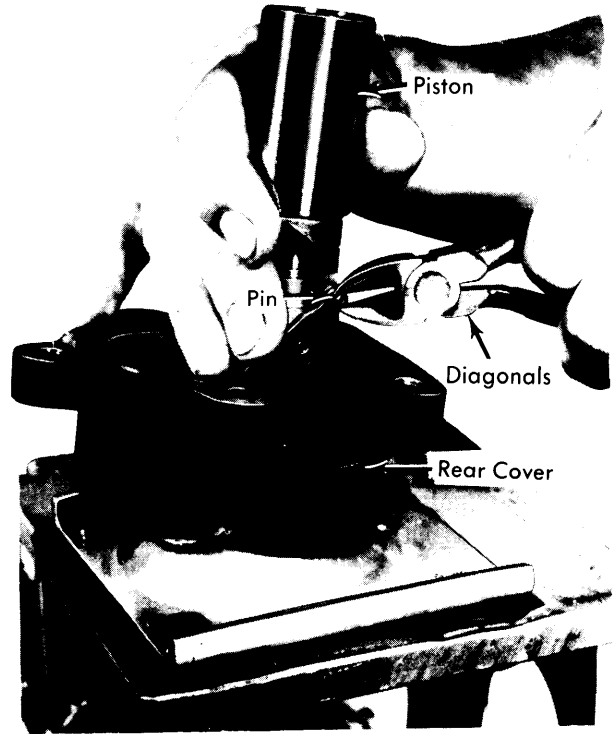

Fig. 7 Booster Piston Pin Removal

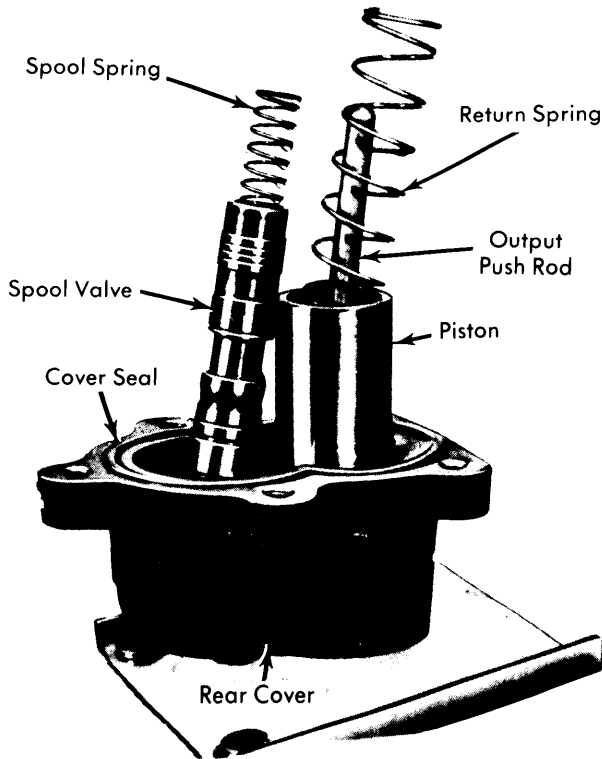

Fig. 6 Booster Rear Cover Assembly

Assembly – 1) Position piston bracket into yoke of lever and install new pin through hole. Using suitable tool (J-26410), mushroom end of pin. Check that lever is free to move with no binding.

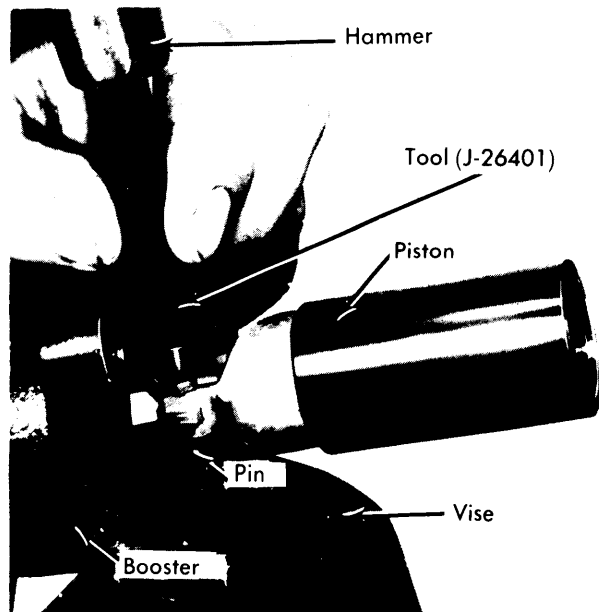

Fig. 8 Staking Booster Piston Pin

BENDIX HYDRO-BOOST (Cont.)

2) Install a new seal in rear cover groove. Install a new power piston seal in front housing. Insert spool valve and spring into front housing bore. Pull up on power piston and extend lever to accept sleeve on spool valve. While holding lever extended, bring front housing with spool valve directly over rear cover and slide lever pins into slot in sleeve.

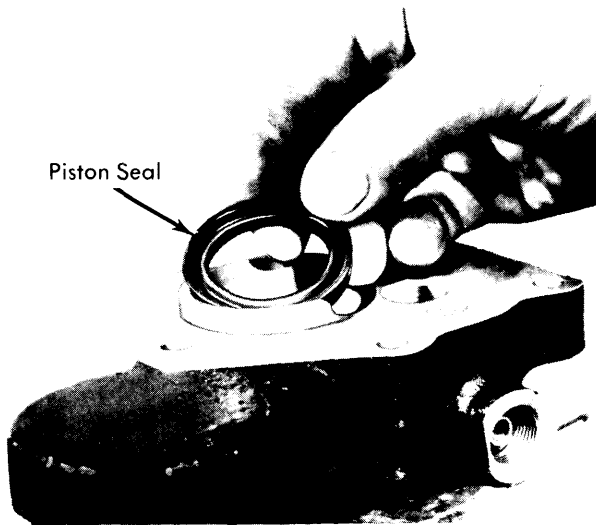

Fig. 9 Installing Power Piston Seal

3) Center power piston in bore and begin to lower front housing down onto rear cover. Before power piston contacts piston seal, push suitable seal protector tool (J-25053) through piston bore until it seats in power piston. Push two housings together and remove tool (J-25053). Install Torx bolts and torque to 20 ft. lbs.

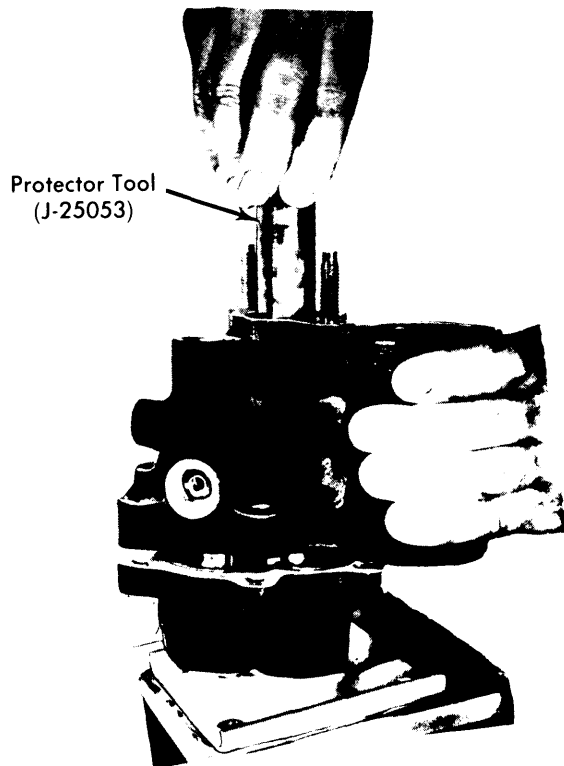

Fig. 10 Installing Seal Protector Tool

4) Install output rod, spring and a new spring retainer. Using $\frac{7}{8}$ " deep socket, tap spring retainer into housing. Install a new strap to support drip pan.

ACCUMULATOR RESERVOIR

CAUTION — Use care when removing accumulator spring cap as spring is compressed to high tension.

Disassembly — 1) Using suitable holding fixture, mount booster assembly in a vise with pedal rod facing downward. Pump pedal rod four or five times to deplete accumulator pressure. Using suitable tool (J-22222-2) placed over spring cap, install a large 12" "C" clamp over spring cap and front housing (see Fig. 11).

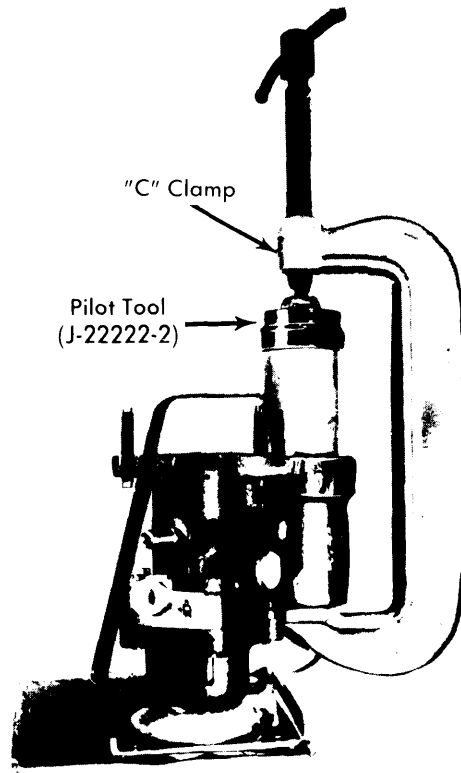

Fig. 11 Removing Accumulator Spring Cap

2) Tighten "C" clamp to depress spring cap slightly. Using a punch inserted through the small hole in side of front housing, unseat retainer ring and remove it from housing. Slowly back off "C" clamp until spring tension is released. Remove "C" clamp, spring cap and accumulator spring.

3) Holding a hand over accumulator piston, apply compressed air to inlet port to force out accumulator piston. Separate front housing from rear cover. See **BRAKE BOOSTER Disassembly**. Remove accumulator plunger seat and guide assembly. Using a small wire hook, remove spacer-charging orifice and ball assembly and discard.

Power Brake Units

BENDIX HYDRO-BOOST (Cont.)

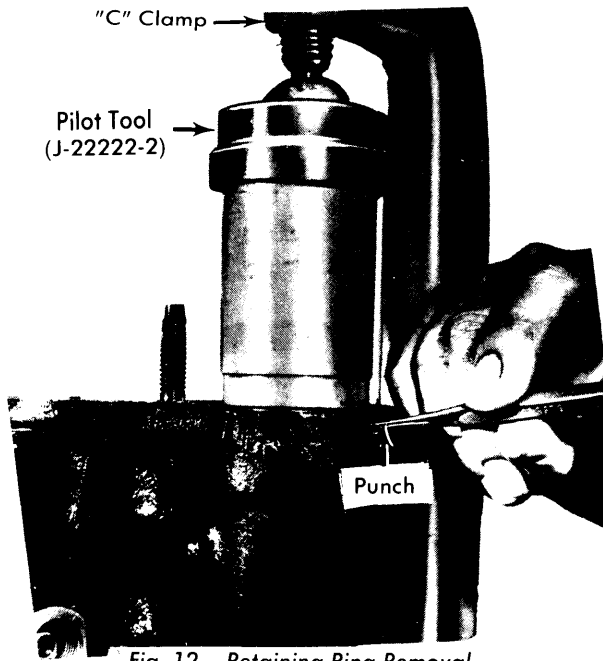

Fig. 12 Retaining Ring Removal

Assembly — 1) Using clean power steering fluid as a lubricant, install new spacer-charging orifice and ball assembly into front housing. Mount a new "O" ring seal onto new accumulator plunger seat and guide assembly and insert into accumulator valve bore. Assemble front housing to rear cover. See *BRAKE BOOSTER Assembly*.

2) Insert a new accumulator piston assembly into front housing bore. If piston cannot be inserted all the way, push pedal rod in to relieve trapped air below piston. **NOTE** — Care must be taken not to disturb relief valve while installing accumulator spring in piston.

3) Mount a new "O" ring (1.987" I.D.) to accumulator cap. Place spring cap and a new retainer ring in position on front housing. Install pilot tool (J-22222-2) on spring cap. Using "C" clamp, depress accumulator cap down until retainer ring can be installed. With retainer ring correctly engaged in groove, remove "C" clamp and install a new drip pan strap.