

FORD MOTOR CO. INTEGRAL POWER STEERING

Ford, LTD II
Mercury, Cougar
Thunderbird
Lincoln Continental & Continental Mark V

ADJUSTMENT

DESCRIPTION

The Ford integral power steering gear is a torsion bar type with rotary valve, input shaft, torsion bar, worm shaft, one piece rack piston, sector shaft and housing. The rotary valve is mounted on the input shaft and controls fluid pressure to each side of rack piston. The input shaft connects to torsion bar and torsion bar engages worm shaft. Worm shaft moves rack piston through recirculating worm balls with the aid of hydraulic pressure. Rack piston is in mesh with sector shaft which is connected to steering linkage.

LUBRICATION, TROUBLE SHOOTING & TESTING

See *Power Steering General Servicing* in this section.

SECTOR SHAFT OVER-CENTER ADJUSTMENT

1) This adjustment may be performed with gear in vehicle. Disconnect pitman arm from sector shaft. Disconnect fluid return line at reservoir, cap reservoir return line fitting. Place return line in container and cycle steering wheel to discharge fluid from gear. Remove horn button and turn steering wheel to within 45° of left stop. Using an INCH lb. torque wrench on steering wheel nut, measure rotational drag required to turn gear about 1/8 of a turn from the 45° position, and record reading.

2) Turn steering wheel to straight-ahead position and measure over-center drag torque in both directions. Reading should be 11-12 INCH lbs. greater than torque measured at 45° from stop. If adjustment is required, loosen adjuster screw lock nut and turn screw to adjust sector mesh load. Tighten adjuster screw lock nut and recheck rotational drag torque.

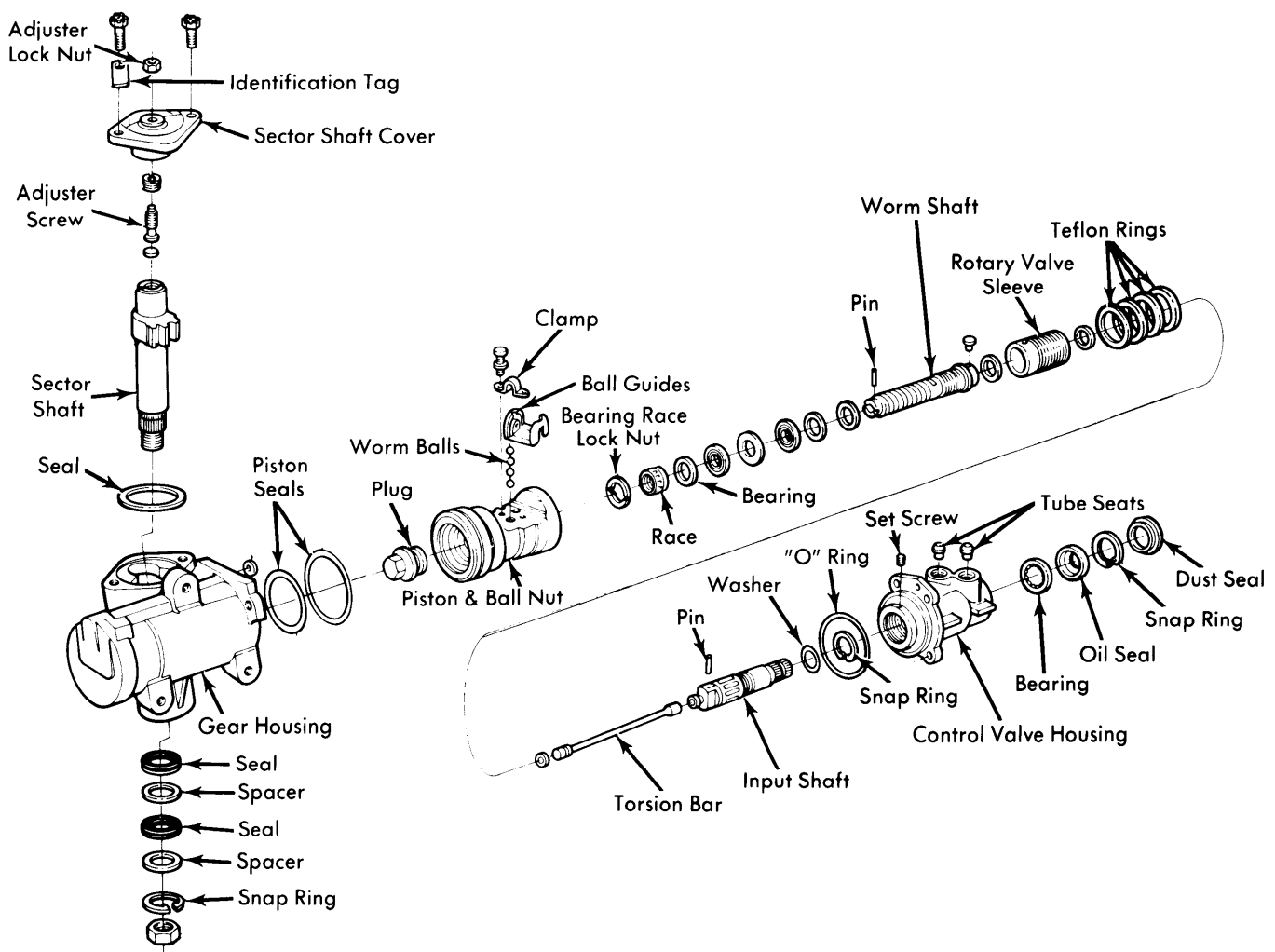

Fig. 1 Integral Power Steering Gear

FORD MOTOR CO. INTEGRAL POWER STEERING (Cont.)

Reconnect return line and add fluid as necessary. Install pitman arm and tighten nut as required. Install horn button unless Rotary Valve Centering Check will be made.

Sector Shaft Over-Center Specifications

Application	① INCH Lbs.
All Models	17 Max.
① — Must be 11-12 INCH Lbs. greater than worm bearing preload which is 2-8 INCH Lbs.	

ROTARY VALVE CENTERING CHECK

1) Install a 0-2000 psi pressure gauge in pressure line between the pump outlet port and steering gear inlet port. Ensure that valve on gauge is fully open. Check reservoir fluid level. Start engine and turn steering wheel to bring fluid to operating temperature. Turn engine off and recheck fluid level.

2) With engine running at about 1000 RPM, and steering wheel centered, connect an INCH lb. torque wrench on steering wheel nut. Apply sufficient torque in each direction to obtain a gauge reading of 250 psi. The torque reading should be the same in both directions at 250 psi. If difference between readings exceeds 4 INCH lbs., remove steering gear and replace shaft and control assembly. **NOTE** — When performing this test with gear removed from vehicle, perform test as outlined, except measure torque and pressure readings at right and left stops instead of either side of center.

REMOVAL & INSTALLATION

STEERING GEAR

Disconnect pressure and return lines from steering gear. Plug lines and ports in gear to prevent entry of dirt. Remove flex coupling bolts. Raise vehicle and remove sector shaft nut. Use a suitable puller to remove pitman arm being careful not to damage seals. If equipped with manual transmission, remove clutch release lever retracting spring to provide clearance for removing steering gear. Support gear and remove bolts. Work gear free of flex coupling and remove gear from vehicle. To install, reverse removal procedure and tighten mounting bolts as required.

OVERHAUL

STEERING GEAR DISASSEMBLY

1) Drain steering gear and mount it in a soft jawed vise. Remove lock nut and washer from adjusting screw. Turn input shaft to either stop, turn back 1¼ turns to center gear. Remove sector shaft cover screws and identification tag. Tap lower end of sector shaft with a soft hammer, lift cover and shaft from housing as an assembly. Discard "O" ring.

2) Turn sector shaft cover counterclockwise to remove cover from adjuster screw. Remove valve housing attaching bolts. Lift valve housing from steering gear housing while holding piston to prevent it from rotating off worm shaft. Remove valve housing and lube passage "O" rings and discard seals. Stand valve body and piston on end with piston end down. Rotate input shaft counterclockwise out of piston allowing ball bearings to drop into piston. Place cloth over piston, invert and remove bearings.

3) Remove ball guide clamp attaching screws, remove clamp and guides. Install valve body assembly in a suitable holding fixture, loosen allen head race nut screw from valve housing and remove worm bearing race nut. Carefully slide input shaft, worm and valve assembly out of the valve housing (**CAUTION** — Due to close clearance, slightest cocking of the spool may cause it to jam in housing).

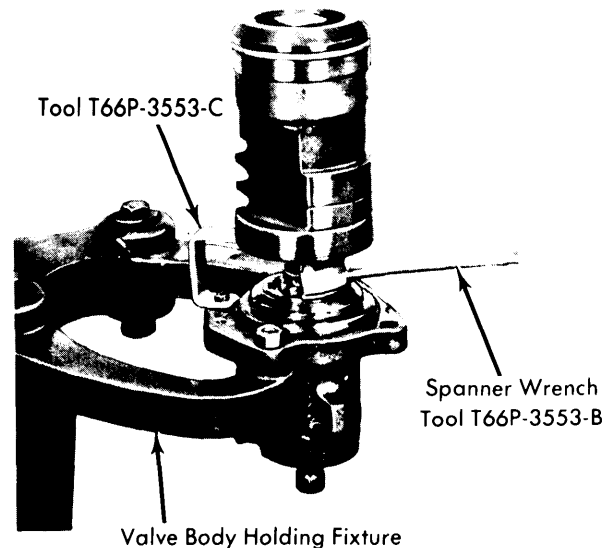

Fig. 2 Removing Worm Bearing Race Nut

STEERING GEAR HOUSING

Remove snap ring and spacer washer from lower end of housing. Using a suitable puller, remove lower seal, spacer washer and upper seal from housing. Lubricate seals and sector shaft bore. Position sector shaft inner seal into housing, lip facing inward. Press seal into place. Place a .090" spacer washer on top of seal, press outer seal into place with lip facing inward. Place a .090" spacer washer on top of seal and install snap ring.

VALVE HOUSING

Remove dust seal and snap ring, discard seal. Invert housing, using a suitable tool, tap out bearing and seal (discard seal). **CAUTION** — Do not damage valve bore. Remove inlet and outlet tube seats with an EZ-out if they are damaged. Coat new tube seats with vaseline. Position seats, install and tighten tube nuts to press seats in proper location. Coat bearing and seal surface of housing with vaseline. Position bearing in housing, and using a suitable tool press bearing in position. **NOTE** — Make sure bearing is free to rotate. Dip new oil seal in gear lubricant and place it in housing metal side out. Drive

FORD MOTOR CO. INTEGRAL POWER STEERING (Cont.)

seal into housing until outer edge of seal does not quite clear snap ring groove. Place snap ring in housing, and using a suitable tool, drive on the ring until ring seats in its groove to properly locate seal. Place dust seal in housing with dished side facing out. **NOTE** - Seal must be located behind undercut in input shaft.

WORM & VALVE SLEEVE

1) Remove valve sleeve teflon rings only if scratched or worn and service replacement is necessary. **NOTE** - A suitable tool kit (T75L-3517-A), is required to install and size valve sleeve teflon rings. Remove valve sleeve rings by inserting a knife blade under rings and cutting them off. **CAUTION** - Avoid scratching valve sleeve when cutting rings. Mount worm end of pinion and valve sleeve assembly in a soft jaw vise.

2) Install suitable mandrel tool over sleeve; slide one new valve ring over the tool. Slide pusher tool over mandrel; rapidly push down on pusher tool forcing ring down ramp and into the fourth groove of sleeve. Repeat this procedure three more times, and each time add one spacer tool under mandrel.

3) After installing four valve sleeve rings, apply gear lubricant to sleeve and rings. Install one spacer over input shaft as a pilot for installing sizing tube. Slowly install sizing tube over sleeve valve end of worm shaft onto valve sleeve rings. Ensure rings are not being bent over as tube is slid over them. Remove sizing tube and check condition of rings. Rings must turn freely in grooves.

PISTON & BALL NUT

Remove teflon ring and "O" ring from piston and ball nut. Dip new "O" ring in gear lubricant and install it on piston and ball nut. Install new teflon ring on piston and ball nut. **CAUTION** - Do not stretch teflon ring more than necessary.

STEERING GEAR REASSEMBLY

1) Mount valve housing in suitable holding fixture, flanged end up. Lubricate valve sleeve rings and install worm and valve in housing. Install race nut and tighten as required. Install Allen head race nut set screw through valve housing and tighten as required.

2) Place piston on bench, ball guide holes facing up. Insert worm shaft so first groove is in alignment with hole nearest to center of piston. While turning worm shaft clockwise, as viewed from input end of shaft, place 27-29 balls, depending on piston design, in ball guide. If all balls have not been fed into guide upon reaching right stop, rotate input shaft back and forth while installing remaining balls. After balls have been installed, do not rotate input shaft or piston more than three and one half turns from right stop or balls will fall out of circuit.

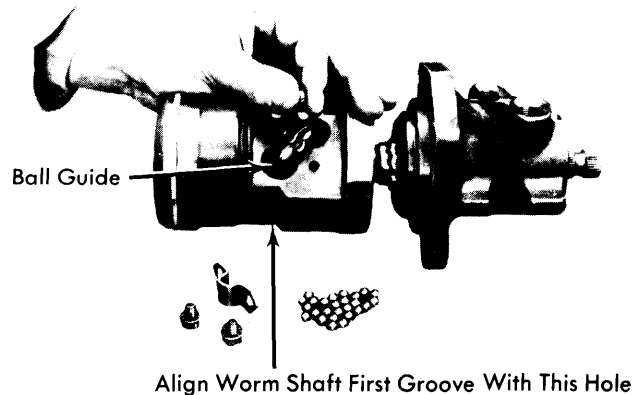

Fig. 3 Installing Piston & Worm Shaft Ball Bearings

3) Secure guides in ball nut with clamp. Position new lube passage "O" ring in counterbore of gear housing. Apply vaseline to teflon seal on piston. Place new "O" ring on valve housing. Slide piston and valve into gear housing. **CAUTION** - Do not damage teflon seal. Align lube passage in valve housing with one in gear housing, and install but do not tighten bolts. Rotate ball nut so teeth are in same place as sector teeth. Tighten valve housing attaching bolts to specifications.

4) Position sector shaft "O" ring in steering gear housing. Turn input shaft as required to center piston. Apply vaseline to sector shaft journal, position sector shaft and cover assembly in gear housing. Install steering identification tag and attaching bolts, and tighten. Using an INCH lb. torque wrench, adjust mesh load. See *Steering Gear Adjustment*.

TIGHTENING SPECIFICATIONS

Application	Ft. Lbs.
Sector Shaft Cover Bolts	55-70
Mesh Load Adj. Screw Lock nut	35-45
Ball Return Guide Clampscrew	42-70 INCH Lbs.
Valve Housing to Gear Housing Screw	35-50
Race Retaining Nut.....	①
Race Nut Setscrew (Allen Head).....	15-25 INCH Lbs.
Piston End Cap.....	70-110
Pressure Hose-to-Gear	16-25
Return Hose-to-Gear	25-34
Hose Clamps	1-2

① - To obtain adapter torque wrench reading, multiply torque wrench length by 72 ft. lbs. (desired tightness), and divide product by sum of torque wrench length plus length of tool (5.5"). Example: With 13" torque wrench, and 5.5" adapter, adapter torque reading would be 50 ft. lbs.