

# Steering Gears

## SAGINAW BALL BEARING WORM & NUT

American Motors  
Chrysler Corp.  
Ford Motor Co.  
General Motors

### DESCRIPTION

Saginaw manual steering gear is of the recirculating ball worm and nut type with steering shaft, worm shaft and ball nut all in line. The ball nut, mounted on worm, is driven by ball bearings which circulate in spiral grooves in both worm and ball nut as a rolling thread. Ball return guides, attached to nut, serve to recirculate both sets of balls. The ball nut is one piece and geared to sector shaft. Teeth on ball nut and sector are designed so a tighter fit exists between teeth when wheels are straight ahead. Worm shaft bearing adjuster is used to provide proper bearing preload on worm shaft. Sector gear lash is set by adjusting screw on end of sector shaft.

### ADJUSTMENT

**NOTE** — Before any adjustments are made to gear, check for binding at frame bracket mounting bolts, instrument panel bracket, or flexible coupling. Steering shaft should run through full range in both directions without binding. Binding indicates misaligned steering gear on mountings or coupling. Always set worm bearing preload before setting sector shaft over-center adjustment.

### WORM BEARING PRELOAD

1) If steering gear is on vehicle, remove horn ring or button and disconnect pitman arm from sector shaft using a suitable puller. **CAUTION** — DO NOT turn steering wheel hard against stops with pitman arm removed from gear as damage to ball return guides may result. Turn steering wheel ½ turn from either stop, then loosen sector shaft adjusting screw several turns to eliminate sector load.

2) Use a torque wrench having a 50 INCH lb. maximum scale or less to measure preload. Attach torque wrench to steering wheel nut and turn through a 90° arc observing torque reading. If torque is less than specified in table, loosen adjuster lock nut and turn worm thrust bearing adjuster to increase preload. Tighten adjuster lock nut and recheck preload.

### SECTOR SHAFT OVER-CENTER ADJUSTMENT

Rotate steering wheel gently from stop to stop counting total number of turns, then turn wheel back half-way to center sector on high spot. Rotate steering wheel ½ turn on either side of center. Using a 50 INCH lb. torque wrench or less on steering wheel nut, turn wheel over sector high spot and note torque. If not within specification in table, loosen adjusting screw lock nut and turn screw until correct over-center torque is obtained. After adjustments are completed, install steering arm and tighten nuts.

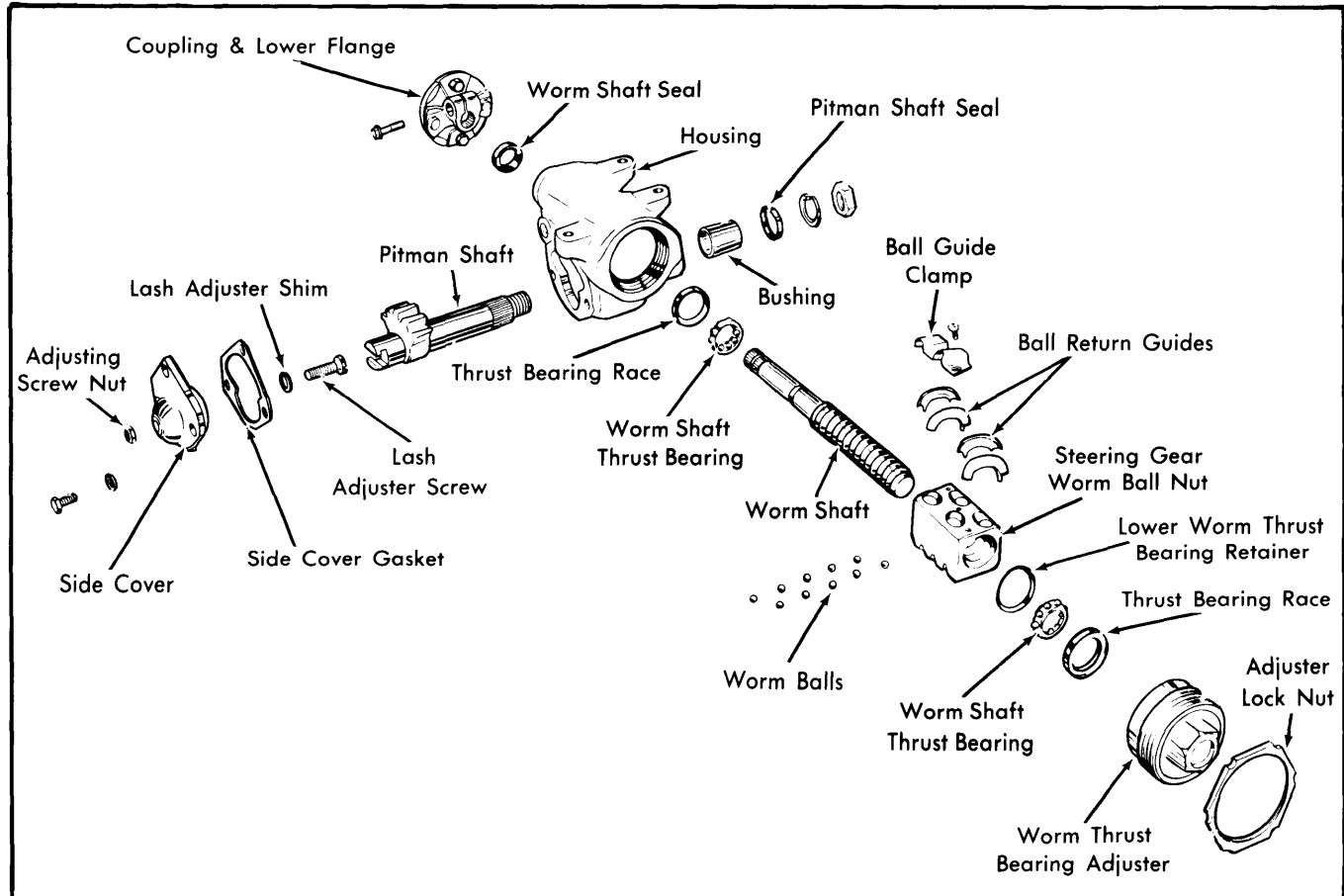

Fig. 1 Saginaw Ball Bearing Worm & Nut Steering Gear

## SAGINAW BALL BEARING WORM & NUT (Cont.)

### Worm Bearing Preload

Model	Preload (INCH Lbs.)
American Motors .....	5-8
Chrysler Corp. ....	1.5-4.5
Ford Motor Co. ③	
16:1 Ratio .....	3-4
22:1 Ratio .....	5-6
General Motors .....	5-8

### Sector Shaft Overcenter Adjustment

Model	Mesh Load (INCH Lbs.)
American Motors .....	① 4-10
Chrysler Corp. ....	② 8-11
Ford Motor Co. ③	
16:1 Ratio .....	② 7-8
22:1 Ratio .....	② 12-13
General Motors .....	① 4-10

- ① — In excess of worm bearing preload. Total not to exceed 16 INCH Lbs.  
 ② — Including worm bearing preload.  
 ③ — 16:1 ratio has I.D. tag number of SMA-B or SMA-Y.  
 22:1 ratio has I.D. tag number of SMA-F.

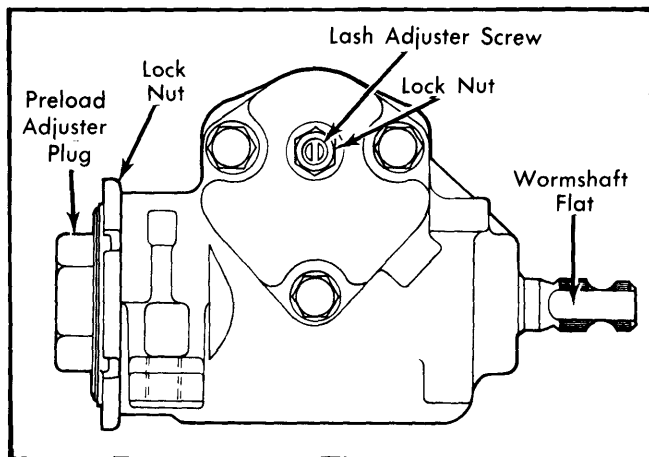

Fig. 2 Adjustment Locations (Typical)

## REMOVAL & INSTALLATION

**NOTE** — Observe the following recommended procedures applying to specific makes and models of vehicles before servicing steering gears.

**American Motors** — With Hornet and Gremlin models, after steering gear installation, the steering column must be realigned to gear assembly. Slight misalignment may cause increased steering effort and additional wear to components. See *Collapsible Steering Columns* in this section.

**Chrysler Corp.** — For all models, to avoid possible damage to energy-absorbing steering column, it is recommended to detach column from its mounting before removing steering gear. See *Collapsible Steering Columns* in this section.

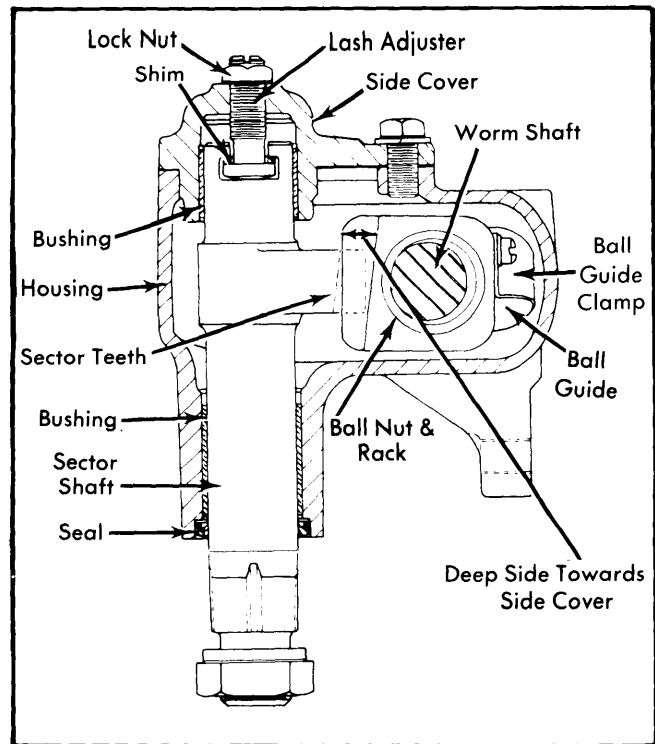

Fig. 3 Steering Gear-Sectional View

**Ford Motor Co.** — Some models equipped with manual transmission require that clutch linkage be disconnected before removing steering gear. With V8 models, it may be necessary to lower exhaust system before removing steering gear.

**General Motors (Flexible Coupling)** — Coupling is known as a captured coupling with a bracket on steering gear side of coupling. If at any time the bracket appears deformed, replace coupling and examine steering column for damage. When installing steering gear, it is recommended to use disposable plastic spacers to obtain correct alignment and spacing between flanges. To install spacers, position all the way on coupling pins before installing coupling to steering shaft flange. After steering gear and column are aligned, and bolts tightened, pull spacers from pins with pliers and discard spacers.

**General Motors (Pot Joint Coupling)** — When installing gear with pot joint coupling, align groove across end of pot joint with flat on worm shaft. Push gear into coupling until worm shaft bottoms in coupling. Tighten gear to frame bolts. Align pot joint clamp with groove across end of pot joint and tighten clamp bolt.

**Oldsmobile** — When installing pitman arm, use only a new lock washer and nut on pitman shaft. If steering gear housing threads for mounting bolts are stripped, replace housing, do not repair housing. When installing all steering gears, apply wheel bearing grease to gear mounting points at frame to prevent squeaks.

**Pontiac** — If steering gear mounting bolts are found loose, replace bolts with new ones.

## SAGINAW BALL BEARING WORM &amp; NUT (Cont.)

## STEERING GEAR

1) Turn steering wheel so wheels are pointing straight ahead. Remove steering gear coupling shield (if equipped). Disconnect steering shaft coupler bolt. Mark alignment of worm shaft to steering shaft for reassembly reference. Raise vehicle and mark position of sector shaft to pitman arm if not master splined. Remove "K" joint or crossmember as necessary. Remove pitman arm fastener and remove pitman arm with suitable puller. **CAUTION** — DO NOT hammer on end of puller to aid removal. Tapping on side of pitman arm should be sufficient for removing pitman arm. Remove steering gear mounting bolts and remove gear from vehicle.

2) To install steering gear, gear and components must be aligned before tightening bolts. Align worm shaft flat or mark to match coupling and install gear with mounting bolts finger tight. Tighten coupling pinch bolt, align gear to coupling and tighten gear mounting bolts. **NOTE** — With captured type couplings, ensure that no metal-to-metal contact exists between flanges. Install pitman arm on sector shaft master spline or as previously marked. Tighten pitman arm nut. Check steering movement for smooth operation before lowering vehicle. Adjust steering column or gear if binding occurs. See *Collapsible Steering Columns* in this section for column adjustment.

## SECTOR SHAFT SEAL

**All Makes (Exc. Chrysler Corp.)** — 1) For most vehicles, shaft seal can be replaced without removing steering gear. Rotate steering wheel from stop to stop counting number of turns, then turn wheel back half-way to center sector. Remove pitman arm using suitable puller. Loosen lash adjuster screw lock nut and turn adjuster screw a few turns counterclockwise.

2) Remove bolts attaching side cover to housing, and lift sector shaft and side cover assembly from housing. Pry sector shaft seal from housing using a screwdriver being careful not to scratch housing bore. Inspect gear lubricant for contamination, if lubricant is contaminated in any way, gear should be completely overhauled.

3) Lubricate new sector shaft seal with suitable steering gear lubricant (GM 4673M). Position seal in sector shaft bore and tap into place using a suitable socket. Remove lash adjuster lock nut, and side cover from sector shaft assembly by turning lash adjuster screw clockwise. Install sector shaft in gear so center tooth of sector enters center tooth space of ball nut. Fill gear housing with lubricant and install a new side cover gasket on gear housing. Install side cover over sector shaft by reaching through cover hole with a screwdriver and turning lash adjuster screw counterclockwise until screw bottoms, then back off screw one-half turn. Install side cover bolts and tighten to specification. Install lash adjuster lock nut and perform steering gear adjustments.

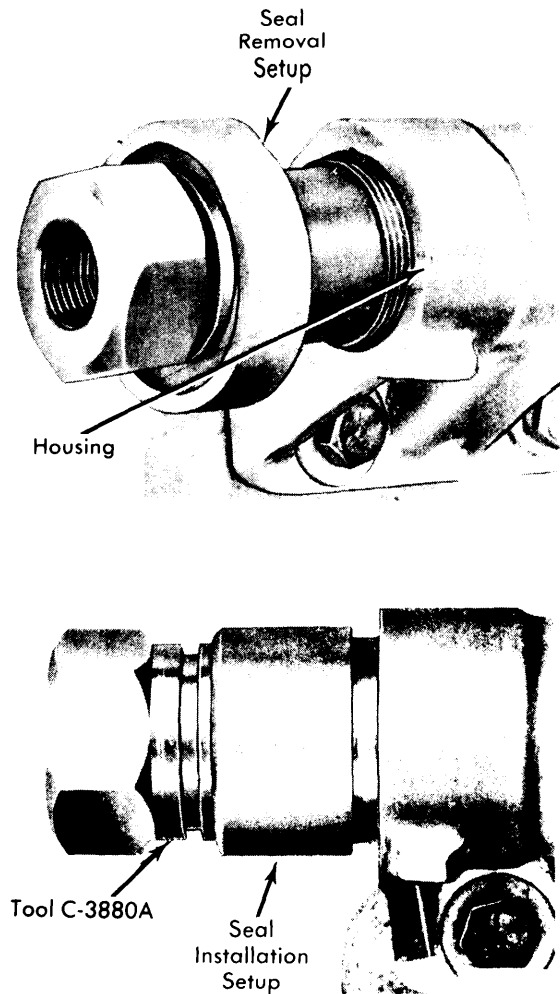

Fig. 4 Sector Shaft Oil Seal Removal & Installation (Chrysler Corp.)

**Chrysler Corp.** — 1) Sector shaft seal can be replaced without removing gear from vehicle using special tool (C-3880A). Tool consists of adapter SP-3056, half rings SP-1932 and nut SP-3610. Clean exposed portions of sector shaft before replacing seal. Remove pitman arm using suitable puller.

2) Slide threaded adapter over end of sector shaft and install nut portion of tool (see Fig. 4). Apply pressure on adapter with nut while screwing adapter into seal until it grips seal firmly. Place two half rings and retainer over both portions of tool. Turn nut counterclockwise to withdraw seal from housing.

3) To install seal, place seal on shaft with seal lip facing gear housing. Place installing adapter against seal. Press seal in until a gap of  $\frac{1}{4}$ " exists between adapter and housing. Place nut from tool set on sector shaft and turn it down against adapter, pressing seal into housing until step on adapter contacts end of housing. Remove tool, install pitman arm and tighten nut to specifications.

## SAGINAW BALL BEARING WORM & NUT (Cont.)

### OVERHAUL

**NOTE** — Clean entire outside surface of steering gear before disassembly to avoid contaminating worm shaft and ball nut assembly.

### DISASSEMBLY

1) Mount gear in suitable holding fixture or clamp gear mounting lug in vise. Turn worm shaft until sector gear is centered on ball nut (straight ahead position). Remove side cover bolts and tap lightly on end of sector shaft to remove.

**NOTE** — All Chrysler Corp. models use needle bearings in place of bushings for sector shaft. It is recommended to use suitable arbor tool (C-3875) to follow up sector shaft as it is removed to retain bearings.

2) If sector gear does not clear opening in housing, turn worm shaft slightly to provide clearance. Remove sector shaft and side cover from housing as an assembly. Separate shaft from cover by turning adjusting screw clockwise. Remove adjusting screw from sector shaft slot using care not to lose shim or screw. **NOTE** — Some sector shaft adjusting screws are staked in two places and cannot be removed.

3) Scribe a locating mark on flexible coupling and worm shaft, and remove coupling from shaft. Loosen worm shaft adjuster lock nut with a spanner wrench or brass drift and remove adjuster nut. **CAUTION** — DO NOT allow ball nut to run down to either end of worm as damage may result to ball guides. Worm shaft should be horizontal when removing adjuster nut and worm shaft assembly. Remove worm shaft bearing from adjuster nut with a screwdriver and remove second worm shaft bearing by turning housing on end, bearing should fall out.

4) Do not disassemble ball nut unless there is indication of binding, tightness or wear on worm shaft. **NOTE** — On Chrysler Corp. vehicles, ball nut and worm shaft are serviced as an assembly and components are not to be disassembled. To disassemble ball nut for other models, remove ball guide clamps and turn ball nut over a clean pan to catch balls. Rotate worm shaft slowly from side to side to remove all balls and remove worm shaft.

### CLEANING & INSPECTION

Wash all parts with clean solvent and blow dry with air. Inspect worm and nut grooves for scoring or pitting. Examine all bearings, bearing cups, shaft surfaces, bushings and oil seals for wear or damage. Replace components as required.

### COMPONENT SERVICE

**Sector Shaft & Worm Shaft Seals** — Pry out seals using a screwdriver if not previously removed. Before installing new seals, check condition of sector shaft bushings and upper worm shaft bearing race. Use a suitable size socket pressing on outer seal diameter to install seals.

**Sector Shaft Bushings** — Support gear housing in a suitable arbor press and press sector shaft bushings from housing using suitable tool (J-1614). **NOTE** — With Chrysler

Corp. die-cast aluminum housing steering gears, bushings and housing are serviced only as an assembly. Press out old bushings with tool inserted in housing from lower end.

**Worm Shaft Bearing Cups** — Remove bearing cup from adjuster plug using suitable puller and slide hammer. Remove bearing cup from housing with a punch. To install bearing cups, press in new cups with a bench press.

### REASSEMBLY

**NOTE** — Some steering gears have ball nut guides with top loading hole for balls. To assemble this type, coat inside of worm, ball nut and guides with oil then install guides into ball nut with nut installed on worm. Load all balls through holes in guide then install guide clamp. Clamps for side loading guide are not the same as for top loading guide. Do not interchange or balls will fall out.

1) Lubricate all seals, bushings and bearings before reassembly. Use steering gear lubricant whenever possible, if not available, a good grade of multi-purpose lubricant may be used. **NOTE** — Do not use gear oil. Place worm shaft in ball nut so taper of rack teeth will be in correct relation to sector teeth. Divide ball bearings to provide an equal number for each circuit. Fill one circuit at a time gradually turning worm shaft away from hole being filled. With side loading guides, fill each return guide with balls and use vaseline to hold balls in place while installing guides.

2) Install worm shaft bearings in housing and in adjuster plug. Install adjuster plug bearing retainer if equipped. Lubricate threads of adjuster before assembly. Wrap tape around worm shaft splines to protect seal during shaft installation. Install worm and nut assembly in housing and tighten adjuster plug hand tight. Before installing sector shaft, pack worm shaft cavities in housing above and below ball nut with lubricant. When gear is properly packed with lubricant, it will hold 11 ounces (about 7-9 ounces for sub-compact models).

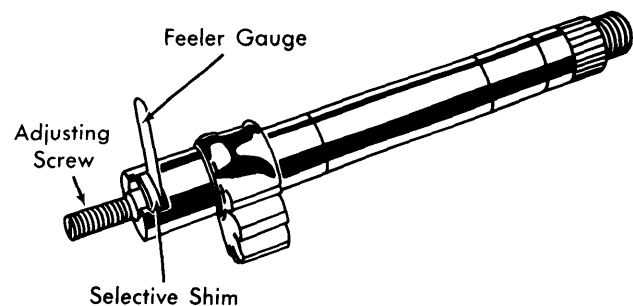

Fig. 5 Checking End Clearance

3) The adjusting screw must turn freely and have a maximum of .002" end play (.004" for Chrysler Corp. & Ford Motor Co. vehicles). Shims are available for selective fit of adjustment screw. Turn worm shaft so ball nut is at center of travel and install sector shaft. Tape sector shaft splines to protect seal. Make certain that sector shaft center tooth meshes with ball nut center tooth space. Pack remaining portion of lubricant in gear. Place new side cover gasket on housing and install side cover by turning adjusting screw. Make sure some lash exists before tightening cover bolts. With some steering gears, it may be necessary to fill gear with lubricant after installing side cover. Fill gear through filler plug hole or one side cover bolt hole. Adjust worn preload and over-center adjustments as previously outlined.

# Steering Gears

## SAGINAW BALL BEARING WORM & NUT (Cont.)

### TIGHTENING SPECIFICATIONS

Application	Ft. Lbs.
Worm Adjuster Lock Nut	
All (Exc. Chrysler Corp.) .....	75-85
Sector Adjusting Screw Lock Nut	
General Motors "H" Series .....	⊙15
All Others .....	25-35
Side Cover-to-Housing	
General Motors "H" Series .....	⊙30
Ford Motor Co. ....	17-25
Chrysler Corp. ....	25
All Others .....	30
Gear-to-Frame Bolts	
American Motors .....	60
Chrysler Corp. ....	100
Ford Motor Co. ....	50-65
General Motors (Exc. Corvette) .....	70
Corvette .....	30
Pitman Arm-to-Sector Shaft	
American Motors .....	115
Chrysler Corp. ....	175
Ford Motor Co. ....	150-225
General Motors "H" Series⊙	
Monza 4 Cyl. ....	140
Monza V8 .....	185
All Others .....	90-105
Oldsmobile Omega .....	210
All Others .....	185
Flexible Coupling-to-Flange Nuts .....	20-25
Flexible Coupling Pinch Bolt .....	30
Pot Joint Clamp-to-Steering Shaft	
1" Size .....	45-55
5/8" Size .....	35
Steering Wheel Nut	
American Motors .....	25
Chrysler Corp. ....	60
All Others .....	30
Lube Plug .....	3-9

⊙ — Astre, Monza, Skyhawk, Starfire, Sunbird and Vega.