

Movable Steering Columns

FORD MOTOR CO. TILT COLUMN

DESCRIPTION

Two types of steering columns are used. A conventional Convoluted Absorber type is designed to collapse about six inches at the bellows on hard impact. The shift tube and steering shaft collapse in proportion to outer tube. The Mini Extruded Absorber type column has an outer column tube with collar attaching brackets which provide a collapsing system. The upper steering shaft is a solid steel bar with two grooves to accept clips; the lower shaft is a formed steel tube which fits over upper shaft. This design allows for collapsing action. Ford, Mercury, Comet, Maverick and Lincoln Continental use Convoluted type tilt columns. Cougar, Thunderbird, Mark V, Granada, Monarch, LTD II, Mustang, Pinto and Bobcat use Mini Extruded Absorber type tilt columns.

REMOVAL & INSTALLATION

STEERING COLUMN

Removal – 1) Disconnect battery and remove steering wheel. Remove lower instrument panel below steering column. Remove trim shrouds covering column at instrument panel. Disconnect shift quadrant indicator, if equipped. With LTD II, Cougar, Thunderbird and Continental Mark V, remove instrument cluster. See *Ford Switches, Gauges & Speedometer in ACCESSORIES & EQUIPMENT Section*.

2) Disconnect electrical connections and vacuum hoses from column. Remove column toe plate or dust boot at firewall.

Disconnect transmission shift control cable, control bellcrank or rod as equipped. Disconnect steering shaft flexible coupling. Remove fasteners attaching steering column brackets to brake support bracket and lower column. Disconnect ignition switch wiring and remove column from vehicle.

Installation – 1) Install column in vehicle and connect ignition switch wiring. Loosely install bracket bolts to support column while connecting coupling. On models without intermediate shaft and universal joint, the flexible coupling joint flange must be adjusted before tightening column mounts. To adjust coupling on Ford, Mercury and Lincoln Continental models, place a .25" diameter rod between flexible coupling fabric and flange. On all other models, pry up or down on column to align column. Tighten coupling nuts using care not to distort coupling when tightening nuts. Remove spacer rod (if used) and check steering shafts for alignment. Ensure that no metal-to-metal contact exists after nuts are tightened and when turning steering wheel.

2) Tighten column mounting brackets as specified and connect transmission control levers. Push toe plate or boot against firewall and tighten screws or clamp. Connect electrical connectors and vacuum hoses as required. Install instrument cluster if removed. Connect and adjust shift indicator cable if necessary. Install column trim shrouds and section of instrument panel below column. Install steering wheel and check column for proper operation. Adjust transmission linkage and neutral start switch if required.

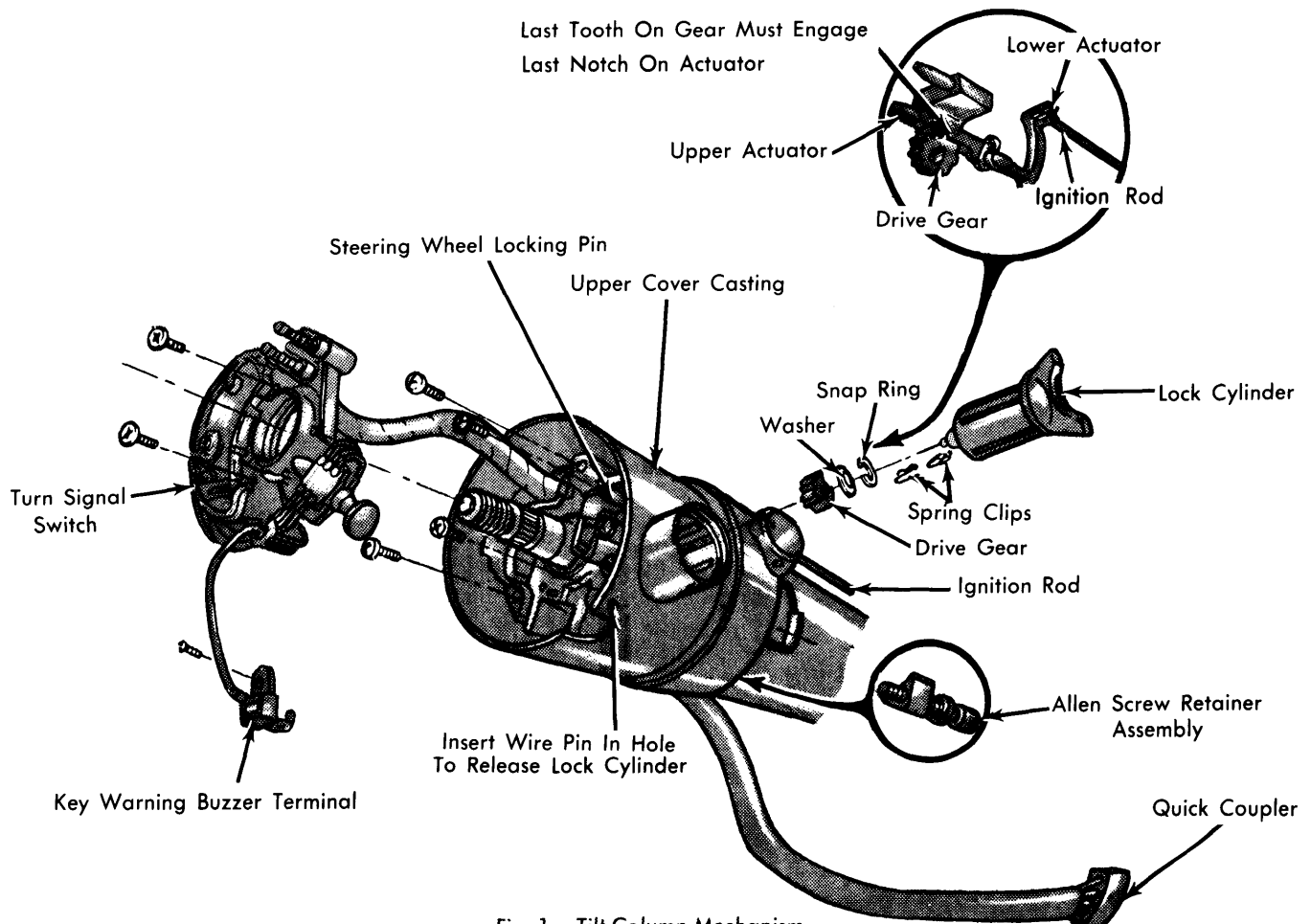

Fig. 1 Tilt Column Mechanism

Movable Steering Columns

FORD MOTOR CO. TILT COLUMN (Cont.)

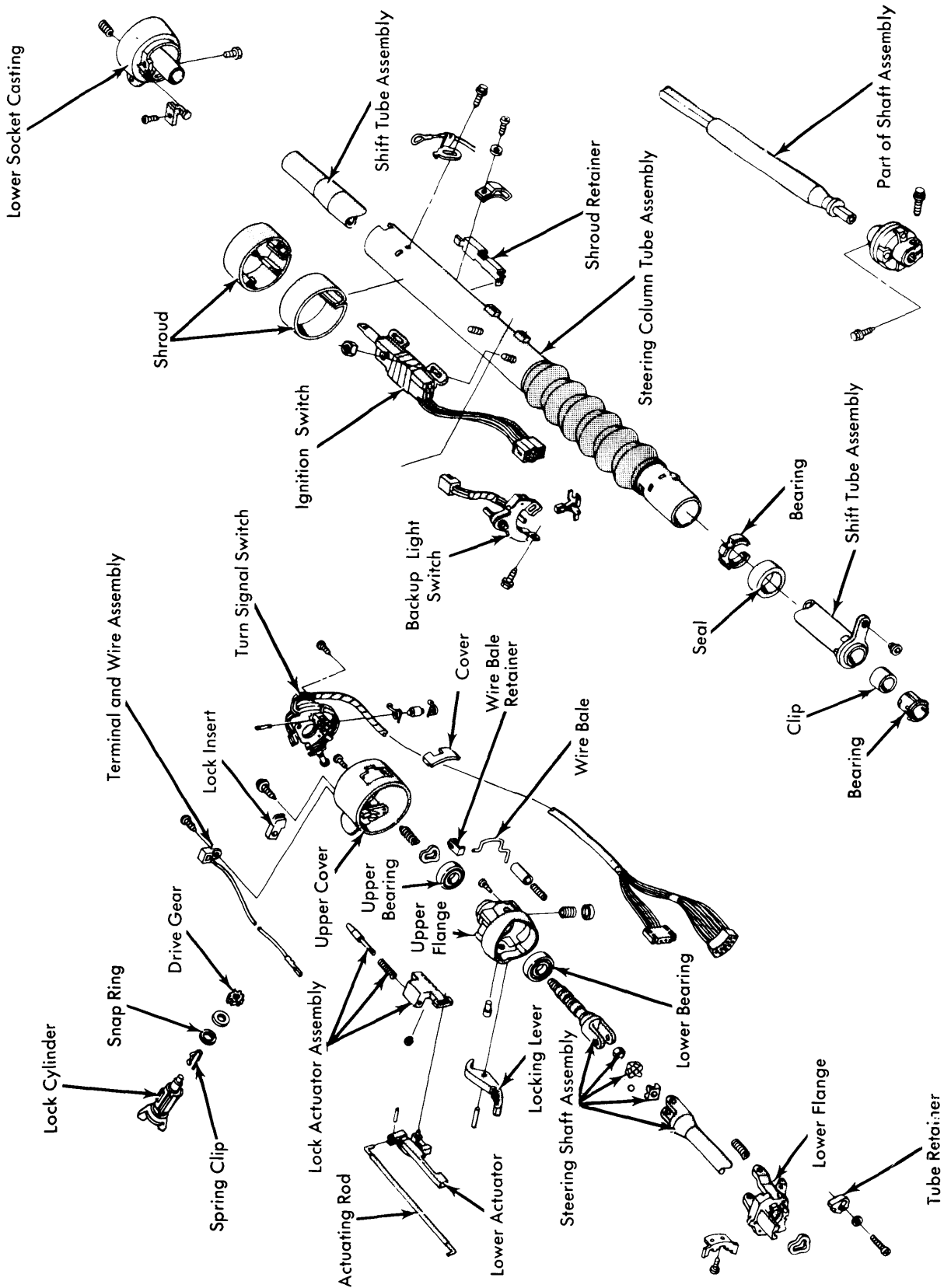

Fig. 2 Ford Convoluted Absorber Tilt Column

Movable Steering Columns

FORD MOTOR CO. TILT COLUMN (Cont.)

DISASSEMBLY & REASSEMBLY

CAUTION — Components and fasteners used in steering column design are important in that they can affect vehicle safety and the performance of vital systems if not serviced properly. All replacement parts must be of same part number or equivalent quality. DO NOT use a part of lesser quality or substitute design. Torque all fasteners as specified during reassembly.

TILT MECHANISM

NOTE — On Granada and Monarch models, remove steering column prior to removing tilt mechanism.

1) Disconnect negative battery cable and remove steering wheel while in "UP" position. Remove trim shroud that covers column. Remove section of instrument panel below column. With Mini Extruded absorber type column, remove instrument cluster from main instrument panel. Disconnect all electrical connections to steering column. Remove wires from hard-shell plastic coupler. Mark position and color code of each wire in coupler. On all columns, remove lock drive gear. See *Ignition Switch Lock Drive Gear*.

2) Remove turn signal lever, signal switch, buzzer terminal and related wiring from column. Remove cover casting screws and lift cover up and over column upper shaft and remove cover from column. Unhook upper actuator from lower actuator and remove. With conventional Convolute absorber type column, loosen toe plate at dash panel. Remove nuts securing column brackets to brake support bracket. Lower steering column to expose ignition switch. With all columns, remove and discard screws securing lower flange casting to column outer tube. Loosen ignition switch nut and remove ignition switch rod from switch end only.

3) Remove spring clips holding wire bale which acts as a release lever for the locking lever. Remove wire bale. With a small punch, drive out pin holding the locking lever. Remove lever and spring. **NOTE** — Use "C" clamp to relieve tension on pin if necessary. Remove column upper shaft snap ring. The upper and lower flange casting can now be separated by removing pivot pins located in side of casting assembly. Use suitable pivot pin removing tool (T70P-3D739-A).

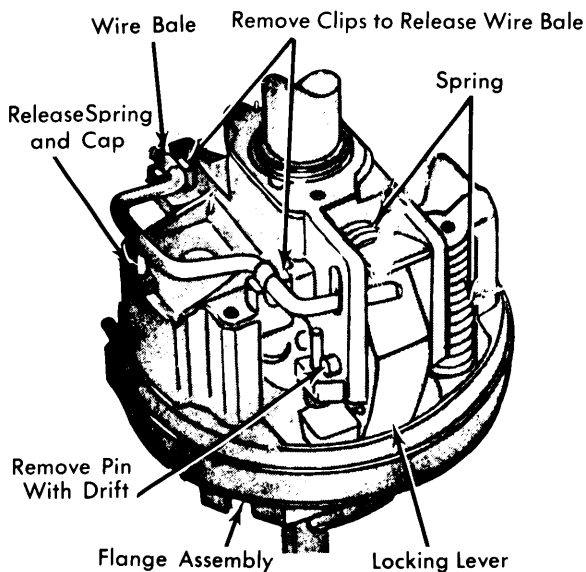

Fig. 3 Removing Wire Bale & Locking Lever

4) To reassemble, reverse disassembly procedure and note following: When assembling flange castings, ensure that column position spring is properly seated between castings. Check that wavy thrust washer is located properly between lower flange casting and socket casting. **NOTE** — Do not use old pivot pins if press fit is loose in lower flange casting. When installing flange assembly to column outer tube, torque screws as required. New screws, washers, and retainers must be used to ensure that epoxy cement on screws will bond properly. Tighten upper cover casting screws as required. Install spring clips and lock cylinder with key in "ON" position. Install retaining pin flush with cylinder and turn key to "OFF" position. Adjust ignition switch. See *Ignition Switches in ACCESSORIES & EQUIPMENT Section*. With all components reassembled, test column for proper operation.

UPPER SHAFT BEARING

With Convolute type column, remove column from vehicle. With Mini Extruded absorber type column, remove tilt mechanism. Place flange casting on bench with smaller end facing down. Tap bearing lightly on outer race at each slot. Turn flange over and remove upper bearing in same manner. Install new bearings by pressing in with a socket on outer race. To reassemble, reverse disassembly procedure.

FLANGE AND/OR SOCKET CASTING

Remove tilt mechanism as previously outlined. Disconnect transmission control rods if equipped. Disconnect and remove flexible coupling from lower steering shaft. Remove steering column shaft assembly from top of column. Rotate column inner tube and socket casting to expose retaining bolt. Remove socket casting retaining bolt and lift casting off inner tube. To reassemble, reverse disassembly procedure.

STEERING COLUMN SHIFT TUBE

Remove steering column from vehicle, and clamp in a vise. Remove back-up lamp switch. **NOTE** — It is not necessary to remove signal switch and wire harness from column. Remove screws attaching lower bearing casting to outer tube. With Mini column, remove lower bearing casting from outer tube. Remove bolt retaining shift tube to socket casting and remove shift tube from housing. To install, reverse removal procedure and note following: Torque shift tube and casting retaining bolt. With Mini type column, torque three screws that retain lower bearing casting to outer tube. **NOTE** — Apply Loctite to threads before installing.

STEERING WHEEL LOCKING BUTTON (IF EQUIPPED)

Remove flange casting. From inside casting, remove snap ring from locking button pivot shaft. Discard the snap ring. Remove locking button assembly and remove return spring from pivot shaft. To reassemble, reverse disassembly procedure. Ensure that spring is retained in lever and against flange casting for lever return action. Install a new snap ring to end of pivot shaft.

STEERING SHAFT & ANTI-RATTLE CLIPS

Remove steering column and secure in a vise. Remove back-up light switch. It is not necessary to remove turn signal switch or wire harness from column. Remove tilt mechanism and steering shaft. Scribe a mark where upper and lower steering shaft sections form a joint line. Separate shaft sections and remove two steel anti-rattle clips and discard clips. To install new anti-rattle clips, reverse removal procedure and note following.

FORD MOTOR CO. TILT COLUMN (Cont.)

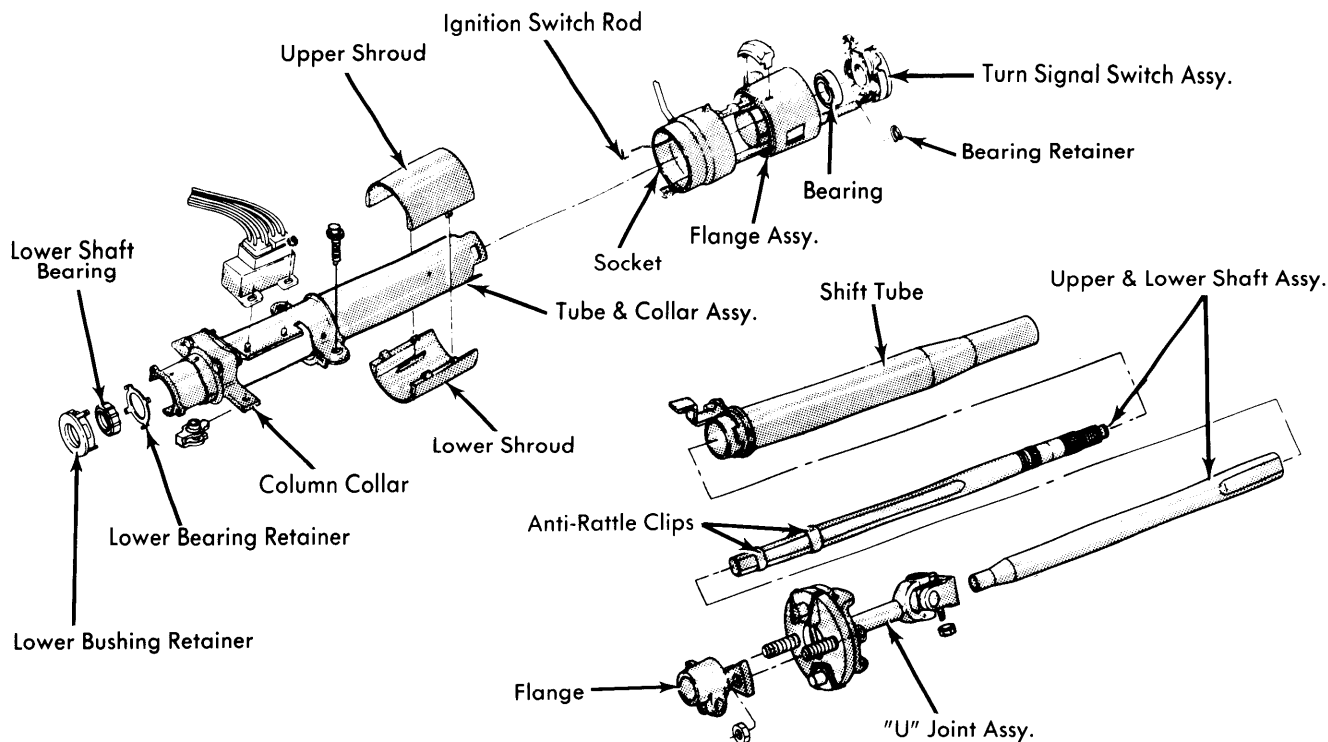

Fig. 4 Ford Mini Extruded Tilt Column

Both clips must be installed in same direction. Lubricate the lower six inches of shaft with chassis lubricant.

LOWER SHAFT BEARING (MINI-COLUMN)

Remove steering column and back-up light switch. Remove three screws holding lower bearing retainer to end of column lower flange casting and remove bearing assembly. The lower bearing can now be snapped out of plastic retainer. To install new bearing, reverse removal procedure and tighten retaining screws as required.

IGNITION SWITCH LOCK CYLINDER

Disconnect battery ground cable and set gear shift in "P". Turn ignition key to "ON" position. Insert a wire pin in hole located on outside of flange casting adjacent to turn signal warning flasher button. Remove lock cylinder while pushing in on wire pin and pulling out on lock cylinder. To install, insert cylinder while in the "ON" position with retaining pin flush with cylinder surface. Then turn key to "OFF" position, this will extend cylinder retaining pin into flange casting.

IGNITION SWITCH LOCK DRIVE GEAR

Remove lock cylinder, then remove cylinder spring clips. Using a screwdriver inserted in drive gear recess, turn lock drive gear three notches counterclockwise. Remove snap ring, washer and lock gear from housing. Note relationship of lock drive gear to position of rack teeth. To install drive gear, reverse removal procedure and note following. Lock drive gear position is correct if last tooth on gear is meshed with last tooth on rack.

TIGHTENING SPECIFICATIONS

| Application | Ft. Lbs. |
|---|-----------|
| Conventional Convolute Column | |
| Flexible Coupling Flange Nuts | 10-22 |
| Flexible Coupling Pinch Bolts | 20-30 |
| Column Bracket Nuts | 13-27 |
| Toe Plate Nuts | 8-14 |
| Toe Plate Clamp Bolt | 5-12 |
| Steering Wheel Nut | 30-40 |
| Mini Extruded Absorber Column | |
| Flexible Coupling Pinch Bolt | 20-37 |
| Universal Joint Lock Nut | 40-45 |
| Vibration Bracket (Exc. T-Bird & Mark V) | 20-37 |
| Lower Collar-to-Brake Support | 20-37 |
| Steering Wheel Nut | 30-40 |
| All Columns | INCH Lbs. |
| Turn Signal Screws | 20-30 |
| Flange-to-Outer Tube Allen Screws | 60-75 |
| Shift Tube-to-Socket Casting | 40-45 |
| Lower Bearing Casting-to-Tube (Mini Only) | 20-25 |
| Lower Bearing Retainer-to-Flange Casting | 12-20 |