

GENERAL MOTORS

Buick
Cadillac
Pontiac

DESCRIPTION

Pneumatic level control system automatically maintains correct rear trim height of vehicle under varying load conditions. This is done by system automatically regulating air pressure to special shock absorbers. System consists of a vacuum operated air compressor (with pressure regulator and integral storage tank), vacuum line to engine, air intake filter and lines, and a height control valve. Compressor is a two-stage type which generates air pressures up to 275 psi in the storage tank. A self-contained regulator valve is preset to maintain pressure to height control valve of not more than 125 psi. Height control valve, linked to rear suspension, admits or exhausts air at shock absorbers as load variances cause a trim deflection of approximately $\frac{1}{2}$ ". A built in time delay system is incorporated to prevent system operation during normal ride suspension height changes.

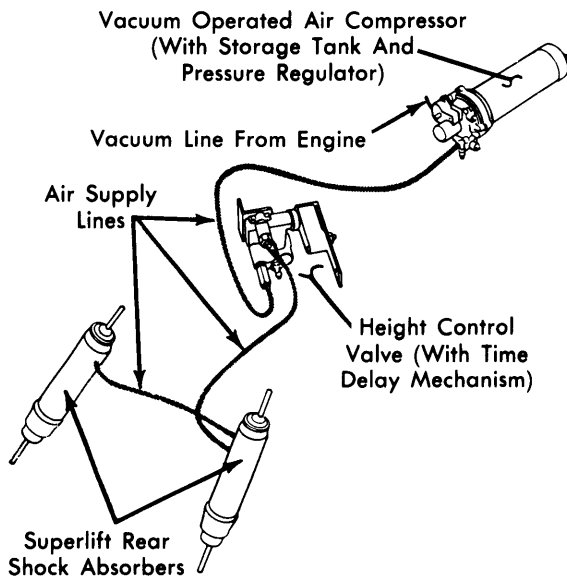

Fig. 1 Automatic Leveling System

TROUBLE SHOOTING

CAR LOADED, WILL NOT RISE

External damage or breakage of components. Leaks in lines. Control valve setting incorrect. Faulty component in system.

CAR LOADED, RISES THEN LEAKS DOWN

Line leak. Height control valve exhaust leak. Shock absorber leak. Height control valve leak.

CAR LOADED, RISES PARTIALLY

Load excessive (over 500 lbs. at axle). Height control valve setting incorrect. Low supply pressure.

CAR UNLOADED, RIDES TOO HIGH, WILL NOT COME DOWN

Height control valve setting incorrect. External damage or breakage. Defective control valve. Supply line and superlift line reversed.

CAR RISES WHEN LOADED, LEAKS DOWN WHILE DRIVING

Time delay mechanism not operating properly.

COMPRESSOR DOES NOT OPERATE DURING DECELERATION PERIOD

Defective vacuum regulator valve assembly. Improper valve spring adjustment. Vacuum leak. Faulty compressor.

TESTING (ON CAR)

NOTE — A test set as shown in illustration is absolutely necessary for proper testing and trouble shooting of this system. This set can be made in the shop using suitable connectors and other parts. Insure all fittings are air tight.

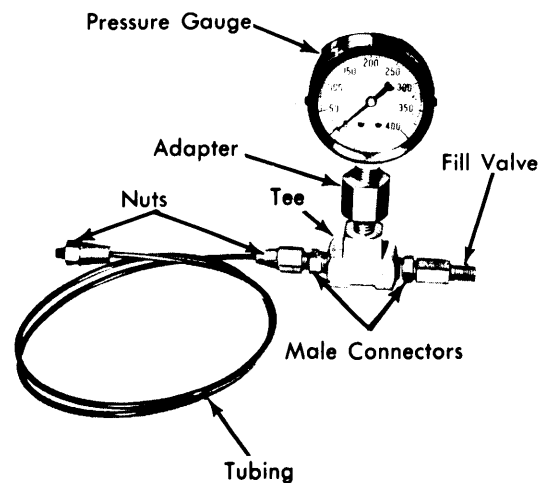

Fig. 2 Test Set

GENERAL MOTORS (Cont.)

QUICK CHECK OF SYSTEM

With car empty, measure distance from center of rear bumper to ground. Add weight equivalent to a two passenger load to rear of car. Car should begin to level in 4-22 seconds, and final position should be approximately $\pm 1/2''$ of unloaded height. Remove weight. After 4-22 seconds car should begin to settle. Final unloaded position should be within approximately $\pm 1/2$ of original measurement.

COMPRESSOR OUTPUT

1) With ignition and all accessories off, deflate system through service valve on compressor. Remove high pressure line at regulator adapter and connect a suitable test gauge (see illustration). Inflate reservoir to 70 psi through service valve and watch test gauge for evidence of leak.

2) If compressor leaks, remove from vehicle and perform leak test. If compressor is not leaking proceed as follows: Operate engine at slow idle and observe reservoir pressure buildup for five minutes. Reservoir pressure should build to a minimum of 100 psi (Cadillac) or 90 psi (Buick and Pontiac).

3) If compressor does not cycle, ensure all lines are open and connected correctly before removing compressor. If pressure buildup is too slow and no restrictions are present in lines, compressor is faulty. If buildup is satisfactory, trouble is in control system.

REGULATOR

NOTE — Test is performed on car with known good compressor.

Deflate system through service valve and disconnect line at pressure regulator valve. Install a test gauge on regulator valve high pressure line fitting. Inflate system through service valve to maximum available pressure. If pressure is less than 140 psi, start engine to assist in pressure build up. Pressure on test gauge should build up to 100-130 psi and hold steady. Check regulated pressure by momentarily depressing valve core on test gauge. Observe gauge reading. If regulated pressure now reads less than 100 psi or exceeds 130 psi, replace regulator assembly.

HEIGHT CONTROL VALVE

NOTE — If tests are performed when car is cold, (15°F or less) time delay may be as much as 30 seconds.

Exhaust (Shock Absorbers Inflated) — Disconnect control valve lever from link, hold lever down in exhaust position until shock absorbers deflate (allow sufficient time for time delay). If shock absorbers do not deflate, remove exhaust adapter from control valve and hold lever down. Replace adapter, "O" ring and filter if this procedure deflates shock absorbers. If above steps do not deflate shock absorbers, replace control valve.

Intake (Reservoir Pressure 125 psi Minimum) — Disconnect overtravel lever from link and hold lever up in intake position until shock absorbers inflate (allowing sufficient time for time delay). If shock absorbers inflate and then leak down, leak test all components of system. If shock absorbers do not inflate, perform leak test on height control valve.

Time Delay — 1) Disconnect overtravel lever from link. Disconnect air lines at shock absorbers and intake ports. Connect test gauge to intake valve port and open air pressure (95 psi). Move overtravel lever approximately one inch down from neutral position, as measured from end of lever and hold for 15-20 seconds. Now quickly move lever upward two inches and note time before air starts to escape from shock absorber port. Delay should be 4-22 seconds.

2) Proceed with check to determine air exhaust time delay. Remove test gauge and plug intake port. Connect test gauge to shock absorber and open air pressure (95 psi). Move overtravel lever approximately one inch up from neutral position as measured from end of lever and hold for 15-20 seconds. Quickly move lever down two inches, and note time before air starts to escape from exhaust port. Delay should be 4-22 seconds. If either delay is not within specifications, replace leveling control valve.

TESTING (OFF CAR)

LEAK TESTING

Compressor, Reservoir, Regulator — 1) With assembly removed from vehicle, but not disassembled, connect test gauge to regulator and inflate reservoir to 80-110 psi. Route a 8" rubber hose between vacuum and vent ports.

2) Place assembly vertically in a tub of water until diaphragm is just submerged. **CAUTION** — Do not submerge assembly completely or water will enter around cover gasket. Check for air leaks. Remove hose from vacuum port and put disconnected end in water. Cover vacuum port with finger. If bubbles are present, second stage housing check valve is probably faulty.

3) If compressor passes leak test but fails output test, overhaul compressor. **NOTE** — If cover gasket is accidentally submerged in water, remove cover and tilt unit so water will drain through openings at distributor valve. Move distributor valve sideways until all water is expelled. Blow dry with air and replace cover.

Height Control Valve — 1) Remove control valve from vehicle and clean exterior. Connect test gauge and air pressure source to intake adapter and apply 80-110 psi. Submerge unit in water. With overtravel lever in neutral position, no air should escape. If there are bubbles from shock absorber port, replace valve.

GENERAL MOTORS (Cont.)

2) Shut off air pressure and disconnect test gauge. Plug intake port with suitable adapter, connect test gauge to shock absorber port and apply air pressure. With overtravel lever in neutral position, no air should escape. If air escapes from exhaust port, replace valve. If air escapes around edge of cover plate, tighten screws or replace gasket. Remove control valve from water and actuate overtravel lever to expel any water, then remove test gauges and air line.

Lines & Fittings — Disconnect overtravel lever from link, hold lever up in intake position, then release. Leak test all connections with soapy water.

Shock Absorbers — Remove shock absorber from vehicle, inflate individually to 50-60 psi (Cadillac and Buick) or 80-110 psi (Pontiac). Submerge in water and if air leaks are present, replace unit.

ADJUSTMENT

TRIM ADJUSTMENT (ON CAR)

NOTE — Trim adjustment should be made with a full fuel tank (or equivalent load at rate of 6 lbs. per gallon).

Raise car with axle supported. Remove shock absorber line at control valve. Connect a fill valve to air supply line. Inflate shock absorbers to 8-15 psi. Jounce car to neutralize suspension. Connect test gauge to shock absorber adapter on control valve and attach an air pressure source (80-110 psi) to gauge. Now loosen height control valve lever adjusting nut. Hold overtravel body in exhaust position until air escapes from exhaust valve port. Slowly move overtravel body and tighten nut at point of minimum air bleed through port. With nut tight, a slight continuous air bleed should be noticeable. Remove tools, lower car and inflate system through service valve on compressor.

REMOVAL & INSTALLATION

HEIGHT CONTROL VALVE

Removal — Deflate system through service valve. Disconnect air lines at leveling valve intake and shock absorber ports. Disconnect link from overtravel lever by removing nut. Remove nuts or screws attaching leveling valve to frame and remove valve.

Installation — Reverse removal procedure, inflating system to 140 psi through service valve.

COMPRESSOR, RESERVOIR, REGULATOR

Removal — Deflate system. Remove air intake and vacuum hoses from compressor. Remove high pressure line from regulator. Remove screws securing compressor to wheelhouse and remove compressor assembly.

Installation — Reverse removal procedure and inflate system to 140 psi through service valve.

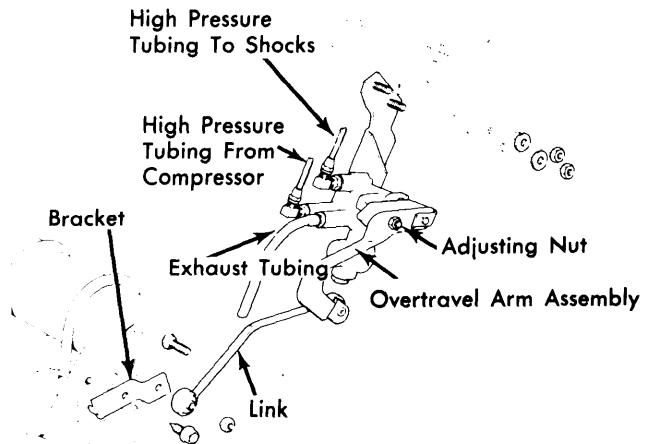

Fig. 3 Height Control Valve

OVERHAUL

COMPRESSOR DISASSEMBLY

1) Remove compressor assembly. Remove adapters and flexible mounts. Remove nuts from reservoir retaining bolts which enter from reservoir flange side of unit. Remove nuts from compressor retaining bolts which enter from compressor side of unit. **CAUTION** — Do not attempt to turn compressor retaining bolts as they have a second nut hidden between reservoir flange and second stage housing. Always remove nuts from bolts while holding bolts stationary. Separate reservoir and compressor assembly and discard reservoir "O" ring seal.

2) Remove cover retaining screw, then remove cover and discard cover gasket. Remove three compressor retaining bolts that hold first and second stage housing together. Separate housings by sliding second stage housing straight off piston.

3) Remove pressure regulator valve assembly retaining screws, remove valve assembly from second stage housing and discard "O" ring seal. Disconnect distributor arm tension spring from swivel arm. Remove actuating arm retaining screw and arm. Carefully slide piston and diaphragm assembly straight out of first stage housing.

GENERAL MOTORS (Cont.)

PISTON & DIAPHRAGM ASSEMBLY

Inspect diaphragm for holes or looseness. Inspect piston seals for evidence of excessive wear or scoring. Replace parts necessary as follows:

Disassembly — Remove diaphragm retainer, plate, diaphragm, second plate and corprene washer. Remove piston seals and "O" rings from piston. Remove check valve in second stage end of piston by inserting suitable punch through air passage from first stage end and tapping.

Assembly — Insure that valve seat is smooth and clean. Install new check valve and spring. Insert new expansion plug retainer and tap in until it bottoms. **NOTE** — Check for proper seating of valve by blowing through small end of piston. No air should pass through. Install new corprene washer, old plate, and second plate. **NOTE** — Position plates so lips face out-board from diaphragm. Press diaphragm retainer into position (see illustration). Install new "O" rings on piston (make sure they are not twisted) and seals on piston (using .020" shim stock to aid installation).

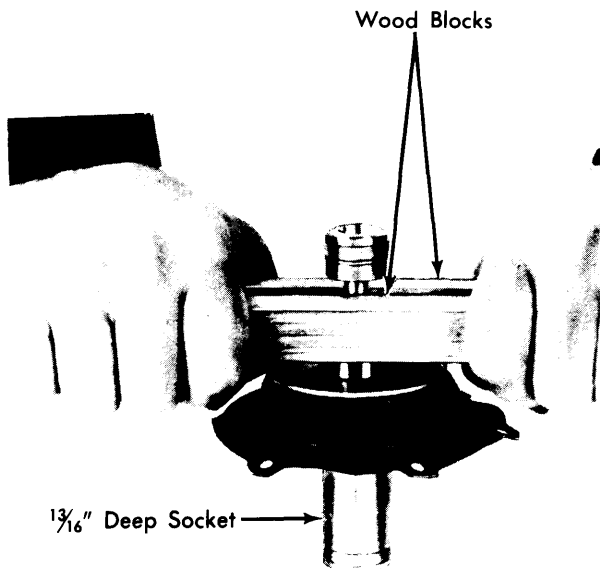

Fig. 4 Installing Diaphragm Retainer

FIRST STAGE HOUSING

Operate distributor valve with finger. Valve tension spring should press against distributor valve and hold it against either stop. If valve operation is not free, new parts should be used at reassembly. If action is free and positive, and no damaged parts are found at disassembly, old parts may be reused.

Disassembly — Remove screw, washer, distributor arm assembly, washer, distributor valve bushing, both arm assembly stop bushings, and both distributor valve stop bushings. Remove distributor valve, making sure valve tension spring is not distorted. Remove tension spring from bowl cover boss, then remove intake valve retaining spring, intake valve, and washer. Remove rocker and swivel arms, if required, by removing pin.

Reassembly — Install rocker arm bushings, rocker arm, and swivel arm in first stage housing. Install rocker arm retaining pin (small end first). Install washer on intake valve and install in housing with intake valve retaining spring. Install longer leg of valve tension spring into boss on first stage housing (do not distort spring), then install distributor valve so short foot of tension spring fits under valve and vertical leg in slot. Install both distributor valve stop bushings, and both arm assembly stop bushings. Install distributor valve bushing, washer, distributor arm assembly, and washer and tighten screw to 12 INCH lbs. **NOTE** — Do not install remaining parts as rocker arm must be free to allow entry of piston into first stage housing.

SECOND STAGE HOUSING (CHECK VALVE)

Removal & Installation — Pry out expansion plug, remove spring and check valve. Put a small amount of solvent into bore and blow dry with air. Check valve seat should be smooth and clean. Install new check valve and spring, then install new expansion plug and tap into place until retainer bottoms.

COMPRESSOR REASSEMBLY

1) Slide piston assembly into first stage (large diameter) housing, install actuating arm and attach to first stage housing with arm pivot screw (tighten to 12 INCH lbs.). Connect arm tension spring to swivel arm, then rotate piston in housing to align elongated hole in diaphragm with vent port in housing.

2) Install through bolts holding first and second stage housings together (housings will align only one way), position nuts in counterbores of second stage housing, and tighten to 28 INCH lbs. Install "O" ring on second stage housing, clean and dry inside of reservoir, then install reservoir on second stage housing and tighten nuts to 28 INCH lbs. Tighten reservoir retaining through bolts to 28 INCH lbs. (bolt heads should be positioned against reservoir and do not install through bolt which holds cover).

3) Install "O" ring on regulator, install regulator on housing and tighten screws to 35 INCH lbs. Service valve should be on same side as first stage housing. Install cover and gasket, tightening retaining screw to 35 INCH lbs. Head of through bolt must be positioned against reservoir. Tighten through bolt to 28 INCH lbs. Install adapters and flexible mounts, test compressor output and install on car.

GENERAL MOTORS (Cont.)

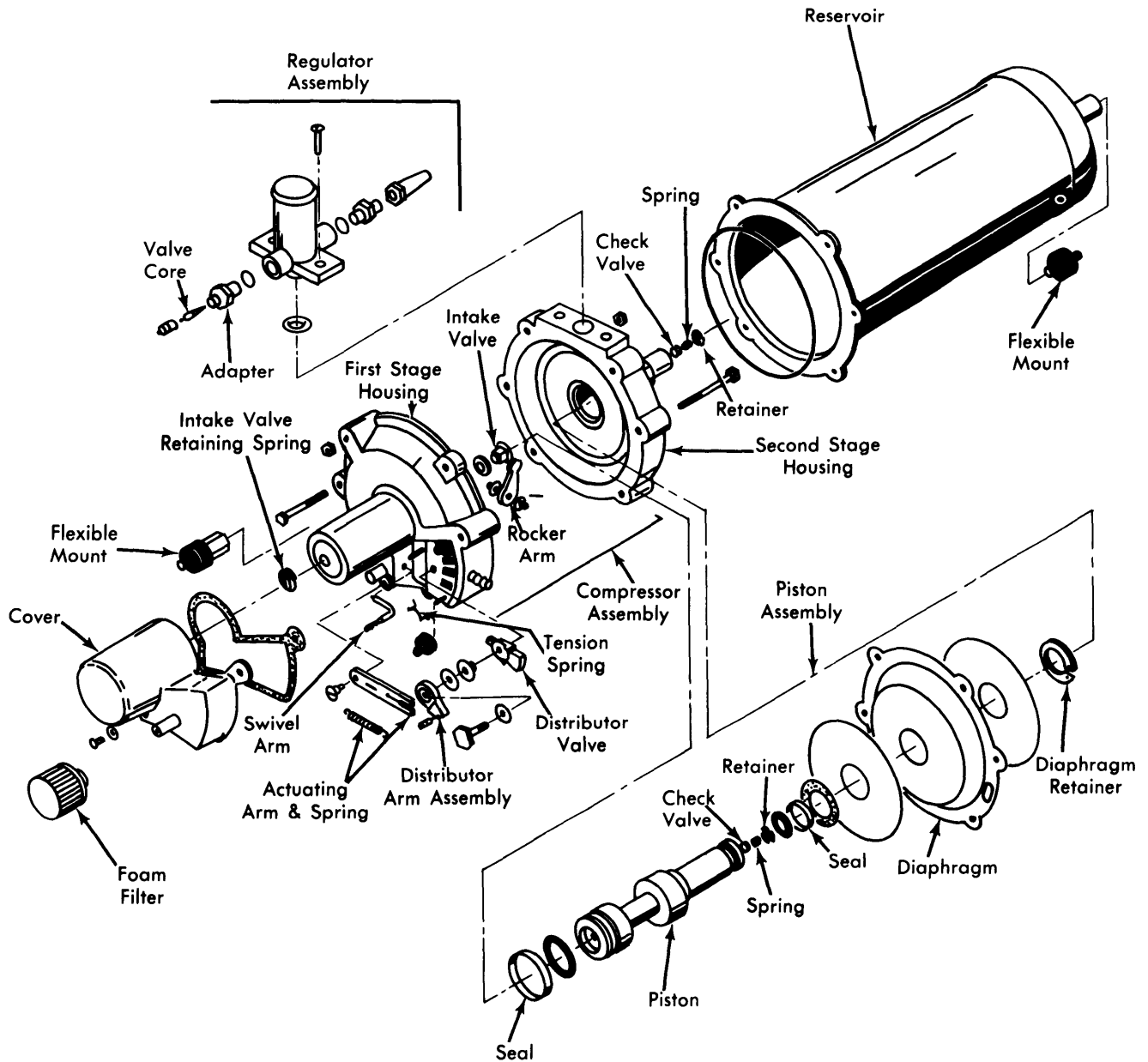

Fig. 5 Compressor, Reservoir, Regulator Assembly