

CHEVETTE

Chevrolet Chevette

DESCRIPTION

The solid rear axle is connected to chassis through two tubular control arms, a track rod, and a bracket at front end of axle extension. Coil springs are used to support the rear axle, while damping is provided by two tubular shock absorbers. The axle extension functions as a short torque tube. A stabilizer bar is also used on some models.

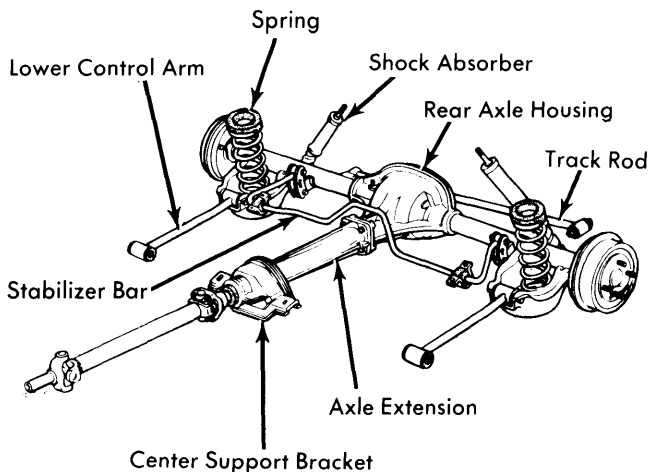

Fig. 1 Chevette Rear Suspension Assembly

ADJUSTMENT

RIDING HEIGHT

See *Riding Height Adjustments and Specifications* in **WHEEL ALIGNMENT** Section.

REMOVAL & INSTALLATION

COIL SPRING

Removal — Raise vehicle and support axle with suitable lifting device. Disconnect both shock absorbers from lower brackets. Disconnect rear axle extension bracket as follows:

Disconnect propeller shaft from companion flange, then remove shaft from transmission. Place a jackstand under front of extension. **CAUTION** — Extension must be supported safely to avoid possible injury when it is disconnected. Disconnect center support bracket from underbody. Lower axle and remove springs and spring insulators, use care not to stretch rear brake hose.

Installation — To install, reverse removal procedure.

STABILIZER BAR (IF EQUIPPED)

Removal & Installation — Raise vehicle and remove bolts securing stabilizer to brackets and link. Remove stabilizer bar. To install, reverse removal procedure.

LOWER CONTROL ARM OR TRACK ROD

Removal — **NOTE** — If both control arms are to be replaced, remove and replace one arm at a time to prevent the axle from rolling or slipping sideways. Raise vehicle and support rear axle. Disconnect stabilizer bar (if equipped). To remove control arm, remove front and rear attaching bolts and remove arm. To remove track rod, remove attaching bolts and rod.

Bushing Replacement — To replace bushings, use appropriate tools to press bushings out of control arm or track rod. Inspect for distortion, burrs, etc. and press new bushings into place.

Installation — Reinstall control arm and or track rod. Do not tighten bolts until vehicle is resting at curb height. Reattach stabilizer bar (if equipped), remove axle support and lower vehicle. Tighten pivot bolts.

TIGHTENING SPECIFICATIONS

Application	Ft. Lbs.
Lower Control Arm Pivot Bolts.....	33
Shock Absorber Upper Mounts.....	7
Shock Absorber Lower Mount.....	21
Track Rod Pivot Bolts	
At Body Bracket.....	67
At Axle Bracket.....	34
Stabilizer Bar Brackets.....	15
Propeller Shaft-to-Companion Flange.....	16
Center Support Bracket-to-Body.....	37