

## ASTRE, MONZA, SKYHAWK, STARFIRE, SUNBIRD & VEGA

Buick Skyhawk  
Chevrolet Monza, Vega  
Oldsmobile Starfire  
Pontiac Astre, Sunbird

### DESCRIPTION

The rear suspension is of link type with coil springs. System uses two lower control arms and one large upper control arm (torque arm), rigidly mounted to differential housing at rear and to transmission, through rubber bushings, at front. In addition, a track rod, mounted between axle tube and body, and a stabilizer bar (optional on some models) are used in the rear suspension system. The two coil springs and shock absorbers are mounted between body and rear axle in a conventional manner.

### ADJUSTMENT

#### RIDING HEIGHT

See *Riding Height Adjustments and Specifications* in **WHEEL ALIGNMENT** Section.

### REMOVAL & INSTALLATION

#### SHOCK ABSORBER

Raise vehicle, support rear axle. Remove upper attaching bolts and lower attaching bolt and nut. Remove shock absorber. To install, reverse removal procedure.

#### COIL SPRING

Raise vehicle, support rear axle with adjustable lifting device. Disconnect shock absorber lower brackets, lower axle, and remove springs and insulators. To install, reverse removal procedure.

#### UPPER CONTROL ARM (TORQUE ARM)

Raise vehicle, support rear axle. Disconnect mounting bracket from transmission. Remove through-bolt and separate bracket from torque arm. Remove torque arm attaching bolts at differential housing and remove arm. To install, reverse removal procedure. **NOTE** — When tightening pivot bolts, car must be at riding height.

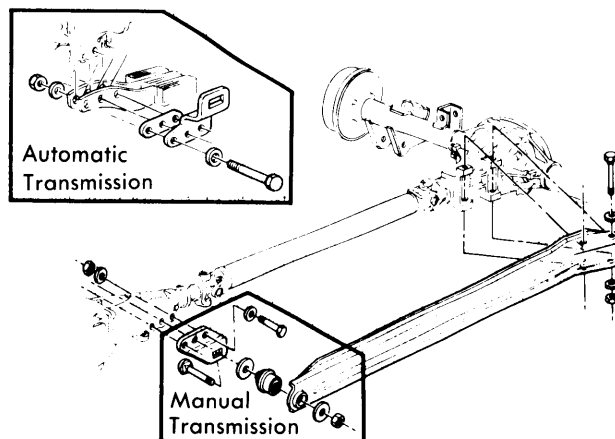

Fig. 2 Upper Control Arm Installation

#### LOWER CONTROL ARM

Disconnect stabilizer bar. With axle housing and frame supported, remove lower control arm rear bracket bolt. If necessary, remove track rod and tap out bolt with a brass drift. Remove lower control arm front bracket nut and bolt. It may be necessary to tap out bolt with a brass drift. Remove lower control arm. To install, reverse removal procedure.

**NOTE** — When tightening pivot bolts, car must be at riding height. Also, when removing and replacing both lower control arms, one side should be completed before opposite side is started, to hold axle in proper location.

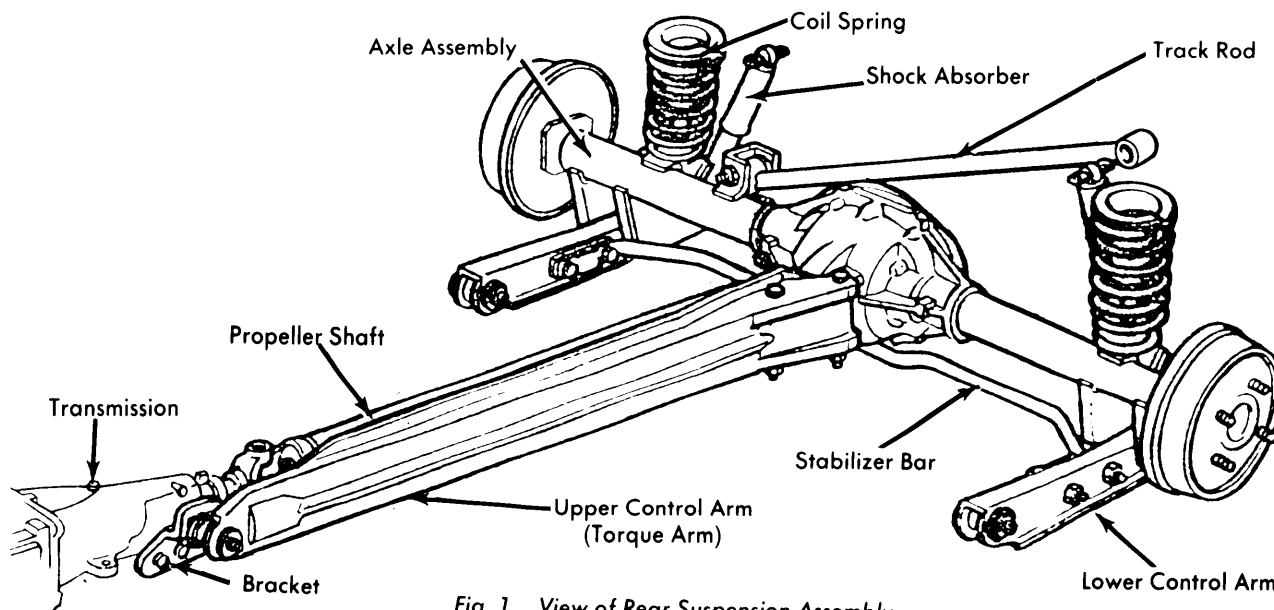

Fig. 1 View of Rear Suspension Assembly

# Rear Suspension

## ASTRE, MONZA, SKYHAWK, STARFIRE, SUNBIRD & VEGA (Cont.)

### BUSHING REPLACEMENT

**Upper Control Arm** — Using suitable tools (J-25317-2 & J-21465-17) and a press, press out old bushing. Place new bushing into position and align any two open spaces in bushing with long axis of upper control arm. Press bushing into arm using suitable tools (J-25317-1 & J-25317-2).

**Lower Control Arm** — Using suitable tools (J-21474-6, J-23555-3 & J-21474-5) and a press, press small end of bushing in largest hole in control arm until bushing flange seats on control arm.

### TRACK ROD

Raise vehicle and support rear axle. Remove bolt at body end of rod, then remove bolt at axle bracket. Remove track rod. To install, reverse removal procedure.

### STABILIZER BAR

Raise vehicle and remove bolts securing bar to control arms. Remove stabilizer bar. To install, reverse removal procedure.

### TIGHTENING SPECIFICATIONS

Application	Ft. Lbs.
Upper Control Arm	
Bracket-to-Transmission .....	25-35
Bracket-to-Control Arm.....	45-55
Control Arm-to-Axle Housing .....	95-135
Track Rod Bolts .....	70-95
Lower Control Arm Bolts .....	70-90
Shock Absorber Mounts	
Upper .....	14-22
Lower .....	35-40
Stabilizer Bar Mounts .....	45-60