

ELDORADO & TORONADO

Cadillac Eldorado
Oldsmobile Toronado

DESCRIPTION

Front suspension is torsion bar with control arms, stabilizer bar and shock absorbers. Front end of each torsion bar is attached to lower control arm. Rear of each torsion bar is mounted at torsion bar crossmember with an adjustable arm for car height adjustment. Steering knuckle is suspended by conventional ball joints. Front wheel bearings do not require adjustment.

ADJUSTMENT

CASTER & CAMBER

See *Caster and Camber Adjustments and Specifications in WHEEL ALIGNMENT Section.*

RIDING HEIGHT

See *Riding Height Adjustments and Specifications in WHEEL ALIGNMENT Section.*

BALL JOINT CHECKING

See *Ball Joint Checking in WHEEL ALIGNMENT Section.*

REMOVAL & INSTALLATION

FRONT HUB & BEARING ASSEMBLY

Removal — Raise car and place jack stand under lower control arms. Remove hub nut, washer, then wheel and tire assembly. Remove $\frac{3}{4}$ of brake fluid from front reservoir of master cylinder. Discard fluid. Use suitable tool (J-22269) to back disc pads away from disc surface and remove disc pads. Remove caliper to knuckle attaching bolts, lift caliper from disc and wire up out of way. **NOTE** — Do not hang caliper from brake hose. Mark hub and disc for reinstallation and remove disc.

Toronado — Remove disc, using above procedure. Install suitable spacers (J-22237) and suitable tool (J-21579) on hub. Install suitable adapter (J-22208-2) on slide hammer and screw adapter into tool on hub (J-21579). Remove three bolts, attaching bearing retainer to knuckle. Using slide hammer, remove hub assembly with bearings.

Eldorado — Remove disc using above procedure. Remove upper ball joint cotter pin and loosen nut. Remove nut and brake hose clip from stud and reinstall nut. Strike steering knuckle in area of ball joint until joint is loose. Place a short length of rubber hose over lower control arm torsion bar connector to avoid damage to tri-pot joint seal lip when hub and knuckle are removed. Remove tie rod end cotter pin and nut, then disconnect tie rod from steering knuckle using suitable puller (J-24319). Separate lower ball joint from suspension using same puller. Detach upper ball joint from steering knuckle. Remove hub and knuckle as assembly.

Installation — To install, reverse removal procedures while noting following: Install all components before tightening nuts and bolts.

STEERING KNUCKLE & SEAL

Removal (Eldorado) — Remove hub and knuckle assembly and pry seal from knuckle.

Removal (Toronado) — Remove hub and bearing assembly, upper ball joint nut and brake hose clip. Position suitable support block (J-22193) under drive axle, to protect constant velocity joint seal. Loosen upper ball joint from knuckle and use suitable tool (BT-7101) to remove tie rod end. Position suitable spacer plate (J-22292-3) between lower ball joint seal and steering knuckle, remove nut and lower ball joint using suitable tool (J-22292-1&2). Remove knuckle and pry seal out.

Installation — To install, reverse removal procedures while noting following: Lubricate seal and install in knuckle using suitable tool (J-23115, Eldorado; BT-6904, Toronado). Cotter pin on upper ball joint must be bent up and flat, to prevent interference with or damage to constant velocity joint seal.

KNUCKLE SEAL (ON CAR — TORONADO ONLY)

Removal (Right Side) — Raise and support vehicle under lower control arms. Remove drive axle cotter pin, nut, and washer. Remove oil filter. Remove inner constant velocity joint attaching bolts. Discard bolts. Push inner constant velocity joint outward enough to disengage from right hand final drive output shaft and move rearward. Unbolt right side output shaft from engine, then remove shaft. Remove drive axle assembly. **CAUTION** — Avoid turning constant velocity joints to extremes. Ensure seals are not damaged against shock absorbers or stabilizer bar. Pry seal from knuckle.

Installation (Right Side) — Lubricate inner lips of seal and install in knuckle using suitable tool (BT-6904). Carefully place right side drive axle assembly into lower control arm and position outer race splines into knuckle. Lubricate final drive output shaft seal, install right side output shaft into final drive and loosely attach support bolts to engine. **NOTE** — When attaching right hand output shaft, do not let it hang. Center shaft in position by moving side to side and up and down. Torque support bolts. Move right side drive axle assembly toward front of vehicle and align with output shaft. Install new attaching bolts and torque to specifications. Install oil filter and drive axle nut and washer. Torque to specifications. Install new cotter pin.

Removal (Left Side) — Raise and support vehicle under lower control arms. Remove wheel and tire assembly. Remove drive axle cotter pin, nut, and washer. Remove tie rod end, using suitable tool (BT-7101). Detach brake hose from clip on upper ball joint, then break joint free from knuckle. Insert suitable removal tools (J-22292 series) and remove lower ball joint. Remove and support knuckle. Pry out seal.

Installation (Left Side) — Lubricate inner lip of seal and install, using suitable tool (BT-6904). Insert lower control arm into knuckle. Do not torque nut. Center left side drive axle assembly into splines of hub and insert upper ball joint stud. Place brake hose clip on stud and install nut. Do not torque. Install tie rod end stud and tighten nut. Tighten upper and lower ball joint nuts. **CAUTION** — Upper ball joint cotter pin must be crimped toward upper control arm to prevent interference with outer constant velocity joint seal. Install drive axle washer and nut. Tighten nut and install cotter pin.

TORSION BAR AND/OR CROSSMEMBER (TORONADO)

NOTE — Torsion bar must be installed on same side of vehicle from which it was removed. Service replacement bars are tagged with a sticker which designate the front end, and are coded as follows:

ELDORADO & TORONADO (Cont.)

Application	Code
Right Hand - Std.	RE
Left Hand - Std.	LE
Right Hand - H.D.	RF
Left Hand - H.D.	LF

Removal - Raise vehicle on two-post hoist and position floor stands under frame torque boxes. Disconnect parking brake cable at equalizer and guide at crossmember support. Detach connectors from rear cables and pull center cable through support. Install suitable removal tool (BT-6601) on crossmember. Turn center screw of tool until seated in dimple of torsion bar adjusting arm. Remove torsion bar adjusting bolt and nut. Count number of turns required to remove (record this number). Further turn tool center screw until torsion bar is completely relaxed. Remove tool. Repeat procedure on other torsion bar. Remove bolts and retainer from torsion bar crossmember at frame. Free torsion bars and adjusting arms. Disconnect hangers at mufflers and tail pipes. Move torsion bar crossmember sideways, as far as possible (it may be necessary to insert block between body and frame). Move crossmember upward and outward until opposite end clears crossmember frame bracket.

Installation - Lubricate 3" of each end of torsion bar with extreme pressure chassis lubricant, then install torsion bar by reversing removal procedures and tighten nuts and bolts. Check riding height and wheel alignment.

lock nuts on "U" bolt, making certain base is pushed up by lock nuts until flush with last thread on "U" bolt and install center bolt. Tighten center bolt until torsion bar adjusting arm is raised high enough to permit removal of adjuster nut. Remove adjuster nut. Loosen center bolt and repeat procedure on other end of crossmember, then remove tool. Remove parking brake cable from guide at right side. Unbolt torsion bar crossmember at both ends. Move crossmember to opposite side from which torsion bar is to be removed. Lower end of crossmember from frame, then drive crossmember rearward until torsion bar is free. **NOTE** - If additional slack is required in brake cable, loosen at equalizer. Remove torsion bar. **NOTE** - Installation will be easier if one torsion bar is always left in place.

Installation - Lubricate 3" of each end of torsion bar with extreme pressure chassis lubricant, then install torsion bar by reversing removal procedures while noting following: Torsion bars are stamped with "L" (left) and "R" (right). Stamped end is installed in lower control arm connector. Check riding height and wheel alignment.

UPPER CONTROL ARM

Removal - Raise vehicle and support under lower control arm. Remove wheel and tire assembly and upper shock attaching bolt. Remove cotter pin and nut on upper ball joint. Disconnect brake hose clip. Unbolt and remove caliper assembly from disc and suspend out of way (Eldorado models only). Disengage upper ball joint from steering knuckle. Remove two control arm bolts and remove control arm by guiding shock absorber through access hole in arm.

Installation - Reverse removal procedures, noting following: When installing bolts into cam assemblies, both bolt holes should be mounted downward. Cotter pin on upper ball joint must be bent upward to prevent damage to constant velocity joint. Check riding height and wheel alignment.



Front Suspension

ELDORADO & TORONADO (Cont.)

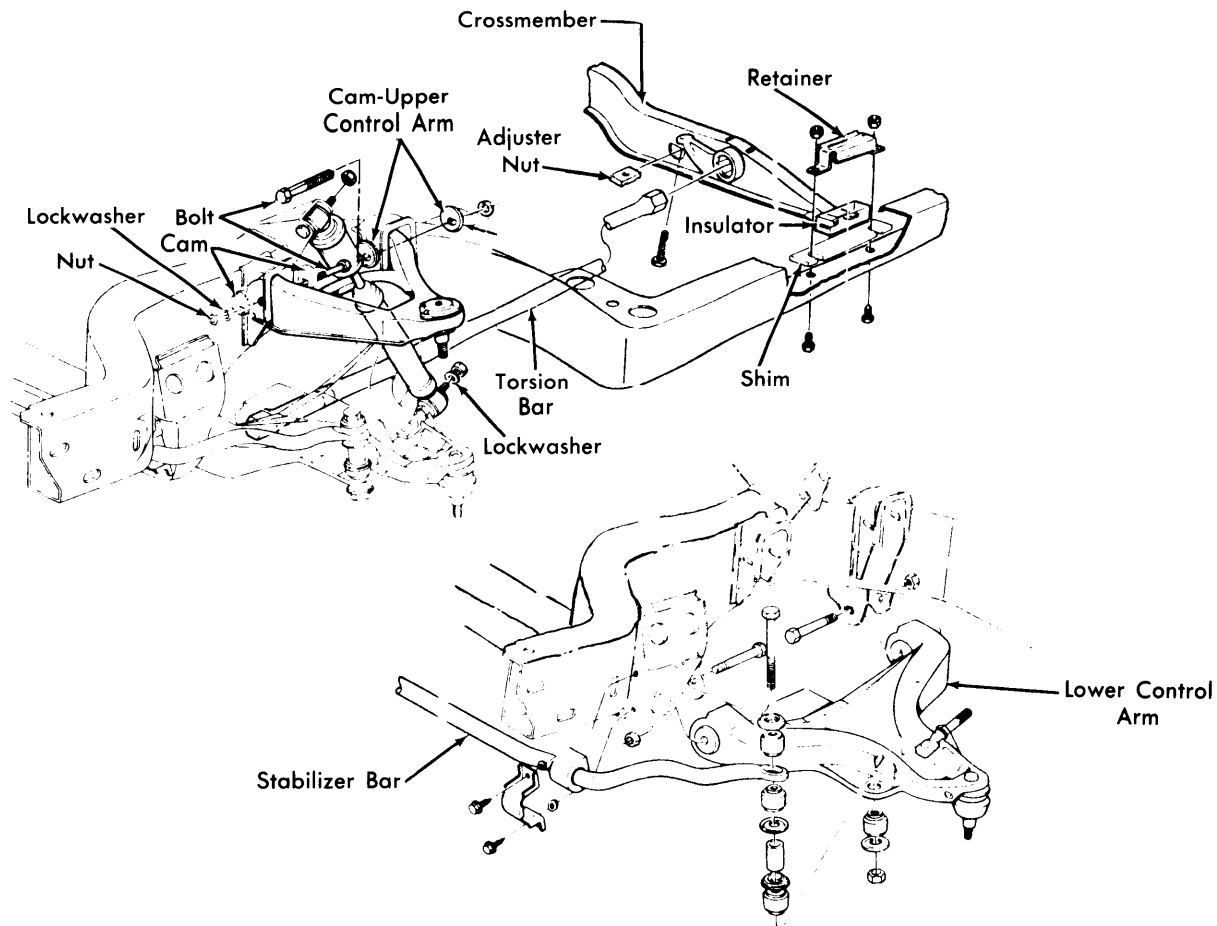

Fig. 3 Eldorado and Toronado Front Suspension Assembly

LOWER CONTROL ARM

Removal — Raise and support vehicle. Remove wheel and tire assembly. Loosen hub nut. Remove torsion bar, as previously described. Remove hub nut and washer. Detach brake hose clips from frame. Unscrew upper ball joint nut, detach brake hose clip, and loosen ball joint stud from steering knuckle. Disconnect shock absorber at lower mount. Detach tie rod end at steering knuckle. Disconnect stabilizer bar, nut, and link bolt. Using suitable puller (J-24319), remove lower control arm from knuckle. Disengage hub, knuckle, and disc, as assembly, from drive axle and secure to upper control arm. Unbolt and remove lower control arm.

Installation — Reverse removal procedures and check riding height. **NOTE** — Upper joint cotter pin must be bent upward to avoid damage to constant velocity joint seal.

Bushing Service — With lower control arm removed from vehicle, spray bushings with silicone lubricant and install suitable tools as shown in illustration. Press bushings out of lower control arm. To install, invert arm on flat surface and place so ball joint end of arm is $\frac{1}{16}$ " above surface. Position

bushings so centerline of notches in bushings are parallel with surface on which arm rests. Press bushings into control arm and install control arm in vehicle.

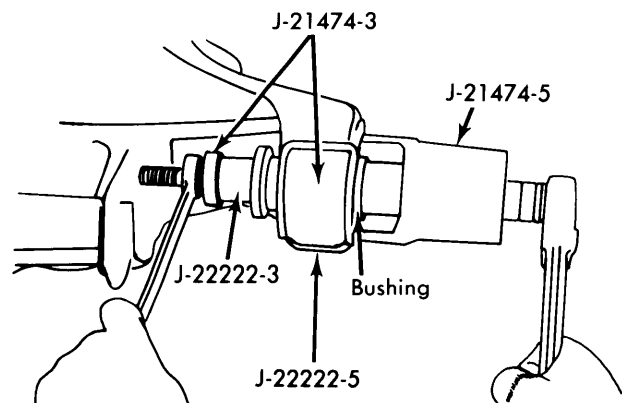

Fig. 4 Lower Control Arm Bushing Removal

ELDORADO & TORONADO (Cont.)

LOWER BALL JOINT

Removal — On Eldorado, remove lower control arm, as previously described. On Toronado, remove steering knuckle, as previously described. On bench, drill or chisel rivet heads from control arm and remove ball joint.

Installation — Install in reverse of removal procedures, using proper service nuts and bolts supplied in kit. On Toronado, check clearance between ball joint nut and drive axle: it may be necessary to grind nut (not more than 1/16").

UPPER BALL JOINT

Removal (Eldorado) — Remove upper control arm, as previously described. On bench, grind off rivet heads, then drive ball joint from control arm.

Installation (Eldorado) — Reverse removal procedures and tighten nuts and bolts. Remove service plug and pack ball joint with suitable grease.

Removal (Toronado) — Raise and support vehicle under lower control arms. Remove wheel and tire assembly. Remove nut and brake hose clip from upper ball joint. Using hammer and brass drift, disengage ball joint from spindle. Raise control arm and drill rivets from ball joint. Remove ball joint.

Installation (Toronado) — Reverse removal procedures and tighten nuts and bolts. Remove service plug and install grease fitting before installing ball joint. Install ball joint with bolts inserted from top side of control arm.

TIGHTENING SPECIFICATIONS

Application	⊙ Ft. Lbs.
Drive Axle Nut	
Eldorado	110
Toronado.....	200
Stabilizer Link Bolt	
Eldorado	13
Toronado.....	15
Stabilizer Bracket-to-Frame	
Eldorado	35
Toronado.....	30
Torsion Bar Crossmember Bolt	
Eldorado	10
Toronado.....	25
Lower Control Arm Bushing Bolt	
Eldorado	80
Toronado.....	90
Upper Control Arm Bushing Bolt	
Eldorado	95
Toronado.....	110
Lower Ball Joint Nut	
Eldorado	8
Toronado.....	95
Upper Ball Joint Nut	
Eldorado	60
Toronado.....	60
Tie Rod-to-Knuckle	
Eldorado	40
Toronado.....	40
Inner C.V. Joint-to-Output Shaft	
Eldorado	65
Toronado.....	75

⊙ — When installing nut which requires cotter pin, turn nut in direction of tightening to align pin hole. DO NOT back off nut to align.