

ASTRE, MONZA, SKYHAWK, STARFIRE, SUNBIRD & VEGA

Buick Skyhawk
Chevrolet Monza, Vega
Oldsmobile Starfire
Pontiac Astre, Sunbird

DESCRIPTION

Ball joint independent front suspension with short and long control arms. Upper arm is bolted to front end sheet metal at inner pivot points. Lower arm attaches with cam type bolts. Coil spring is mounted between lower control arm and shock absorber tower.

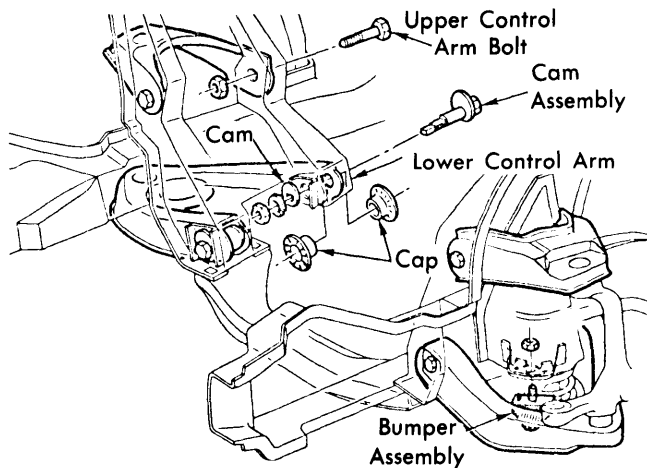

Fig. 1 View of Front Suspension Assembly

ADJUSTMENT

CASTER & CAMBER

See *Caster and Camber Adjustments and Specifications in WHEEL ALIGNMENT Section.*

RIDING HEIGHT

See *Riding Height Adjustments and Specifications in WHEEL ALIGNMENT Section.*

FRONT WHEEL BEARINGS

See *Wheel Bearing Adjustment in WHEEL ALIGNMENT Section.*

BALL JOINT CHECKING

See *Ball Joint Checking in WHEEL ALIGNMENT Section.*

REMOVAL & INSTALLATION

COIL SPRING

Removal — Remove shock absorber and, if equipped, stabilizer bar. Raise and support front of vehicle. Remove wheel and place floor jack under lower control arm. Install a safety chain through spring and around control arm. Disconnect lower ball joint stud from steering knuckle. Remove tie rod end from steering knuckle. Slowly lower control arm with floor jack until spring can be removed.

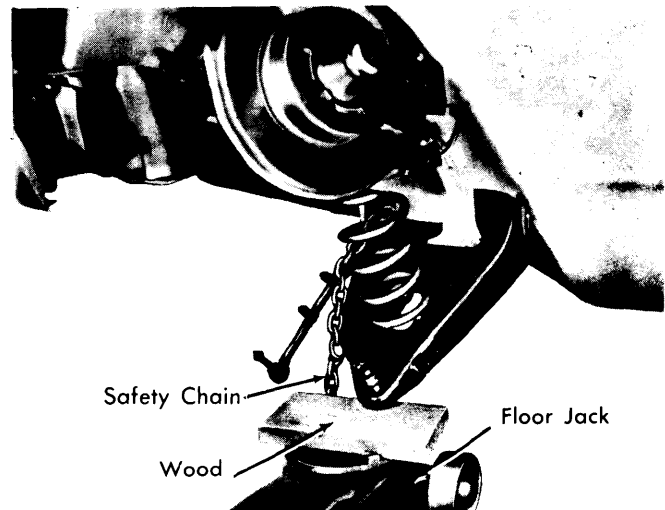

Fig. 2 Removing Coil Spring

Installation — Position coil spring in spring tower as shown in Fig. 3. Guide lower control arm ball joint stud into place in steering knuckle and install stud nut. Tighten stud nut to specifications and install cotter pin. Remove safety chain. Connect tie rod end to steering knuckle. Install shock absorber, stabilizer bar (if equipped), and wheel.

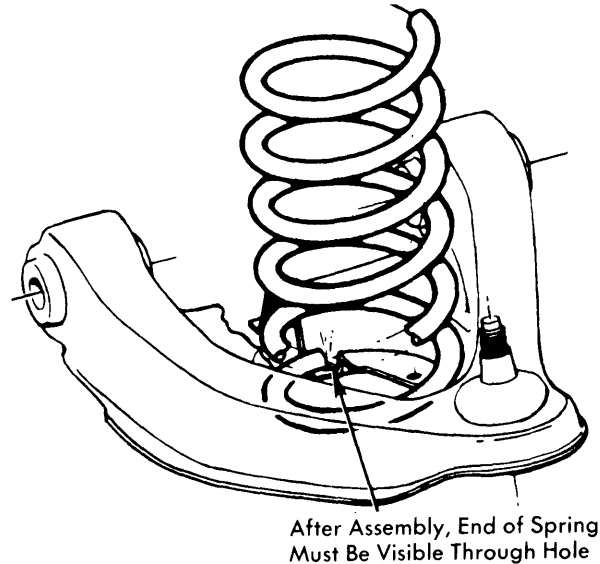

Fig. 3 View Showing Coil Spring Installed Position

BALL JOINT REMOVAL (FROM STEERING KNUCKLE)

Removal — Raise vehicle on hoist and remove wheel and tire assembly. Support lower control arm with floor jack, remove cotter pin from ball joint stud, and loosen nut. Install suitable removal tool (J-23742) with cup end over lower ball joint stud nut. Turn threaded end of tool until stud is free of steering knuckle.

Installation — Mate upper control arm ball stud to steering knuckle and install nut. Tighten nut and install cotter key. Install tire and wheel assembly and lower vehicle to ground.

ASTRE, MONZA, SKYHAWK, STARFIRE, SUNBIRD & VEGA (Cont.)

UPPER BALL JOINT

Removal – Raise vehicle on hoist and support lower control arm. Remove upper ball joint stud from steering knuckle, as previously described. Drill or chisel off rivet heads. Remove ball joint.

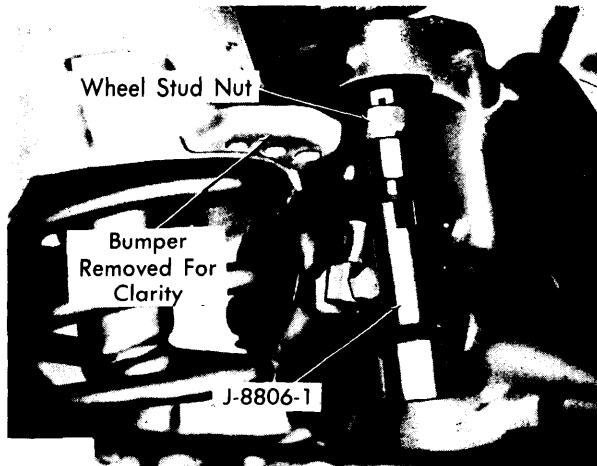

Fig. 4 Positioning of Upper Ball Joint Removal Tools

Installation – Install new ball joint, reversing removal procedures. Attach with parts supplied in service kit. Lubricate ball joint.

LOWER BALL JOINT

Removal – Raise vehicle on hoist and support lower control arm. Free lower ball joint stud from knuckle, as previously described. Install suitable removal tools (J-9519-10, J-9519-7, J-9519-17) and turn hex screw until ball joint is pushed out.

Installation – Position new ball joint with bleed vent facing inward. Using suitable installation tools (J-9519-10, J-9519-16, J-9519-17), turn hex screw until new joint is seated. Lubricate joint. Reinstall joint stud to steering knuckle and tighten nut.

UPPER CONTROL ARM

Removal – Raise vehicle on hoist. Remove wheel and tire assembly. Support lower control arm with floor jack. Remove upper ball stud nut and remove stud from knuckle, using previously described method. Remove control arm pivot bolts and withdraw arm from vehicle.

Installation – Reverse removal procedure, tightening nuts and bolts to specifications.

LOWER CONTROL ARM

Removal – Raise vehicle on hoist. Remove shock absorber. Detach ball stud from steering knuckle and remove coil spring, as previously described. Mark position of cam bolts then unscrew cam nuts. Remove control arm.

Installation – Reverse removal procedures, noting the following: Front cam bolt (camber) must be installed with head toward front of vehicle and rear cam bolt (caster) must be installed with head toward rear of vehicle.

STEERING KNUCKLE

Removal – Raise vehicle on hoist and support lower control arm with floor jack. Remove wheel and tire assembly. Remove caliper assembly from disc and suspend out of way (do not disconnect brake hose). Remove hub, disc and splash shield. Disconnect tie rod end from knuckle. Remove upper and lower ball joints from knuckle and remove knuckle from vehicle.

Installation – Reverse removal procedure, tightening nuts and bolts.

STABILIZER BAR

Removal – Raise vehicle on hoist. Remove nut and bolt from lower control arm. Remove stabilizer bar bracket. Withdraw stabilizer bar.

Installation – Hold bar in position and install body bushings and brackets. Install retainers, grommets, and spacers on lower control arm. Install nuts and bolts.

TIGHTENING SPECIFICATIONS

Application	Ft. Lbs.
Upper Ball Joint Nut.....	ⓐ30
Lower Ball Joint Nut.....	ⓐ60
Upper Control Arm Pivot Nut.....	60
Lower Control Arm Cam Nut.....	125
Lower Control Arm Bumper.....	10
Shock Absorber (Lower Mounting).....	20
Shock Absorber (Upper Mounting).....	8
Stabilizer Bar Bracket.....	27
Stabilizer-to-Control Arm.....	8

ⓐ – Plus a maximum of 1/6 turn to align cotter pin hole. DO NOT back off nut to align hole.