

Wheel Alignment

GENERAL MOTORS (Cont.)

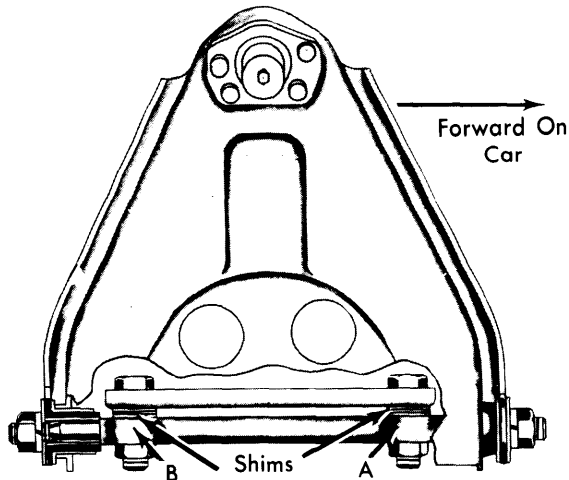

To Decrease Positive Caster: Add Shim At "A"
 To Decrease Negative Caster: Remove Shim At "A"
 To Increase Camber: Remove Shims At Both "A" And "B"
 To Decrease Camber: Add Shims At Both "A" And "B"

Fig. 24 Oldsmobile Caster & Camber Adjusting Shims

CAMBER (STARFIRE)

Loosen front lower control arm pivot nut and rotate cam until specified camber setting is reached. Tighten pivot nut and check caster setting.

CASTER (STARFIRE)

Loosen rear lower control arm pivot nut and rotate cam until specified caster setting is reached. Tighten pivot nut and check camber setting.

OLDSMOBILE TORONADO

TIRE INFLATION (COLD)

Inflate tires to recommended pressures listed on glove box door or rear face of drivers door.

RIDING HEIGHT

Check riding height with full gas tank, front seat rearward, tire pressure correct, doors closed and trunk empty. With vehicle on level floor, bounce several times and allow car to settle. Measure heights as shown in illustration from bottom of rocker molding to floor at points indicated. Measured heights may differ side to side $\pm \frac{1}{2}$ ", front to rear $\pm \frac{1}{2}$ " and have a front to rear slope $+ \frac{3}{4}$ ". To adjust front carrying height, raise car at front crossmember to relieve strain on adjusting bolt. Lubricate adjusting bolt before attempting to change carrying height.

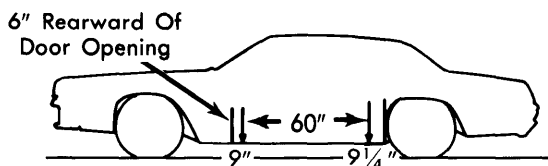

Fig. 25 Riding Height Measuring Points (Toronado)

CAMBER

Adjustments are made by rotating eccentric cam assemblies at inner end of upper control arm front and rear legs. Loosen nuts

on inboard side of upper control arm cam bolts, then turn both front and rear cams in same direction to adjust. Each cam bolt will correct $\frac{1}{2}$ of incorrect setting. Tighten cam bolts to 110 ft. lbs.

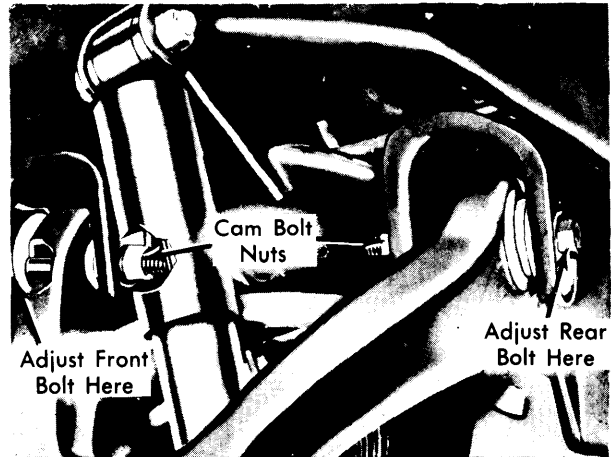

Fig. 26 Toronado Caster & Camber Adjusting Cams

CASTER

Loosen front and rear cam nuts while holding bolts with back-up wrench so camber is not changed. Turn front cam bolt so camber changes an amount equal to $\frac{1}{4}$ desired amount of caster change. Adjust rear cam in opposite direction so camber setting returns to its correct position. Tighten upper control arm cam nuts to 110 ft. lbs. **NOTE** — If not enough cam is available for adjustment, turn front cam so high part is up, and rear cam so high part is down, then set camber and caster.

PONTIAC

TIRE INFLATION (COLD)

Before attempting wheel alignment adjustments, tires must be inflated to specified pressures shown on vehicle placard table.

RIDING HEIGHT

With vehicle at curb height and on a level floor, bounce vehicle several times and allow to settle. Measure heights at locations shown in Fig. 27. Specifications are for new vehicles, most vehicles in use will average 1" less than new vehicles.

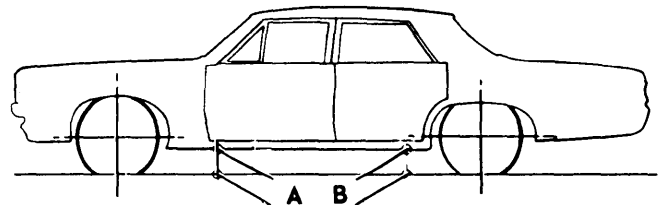

Fig. 27 Riding Height Measuring Points (Pontiac — All Models)

GENERAL MOTORS (Cont.)

RIDING HEIGHT SPECIFICATIONS		
Application	A	B
LeMans & Grand LeMans		
Station Wagons	10.70"	10.70"
All Others	10.22"	9.92"
Grand Prix	10.22"	①9.92"
Catalina, Bonneville		
Grand Safari, Safari		
Coupe & Sedan	②9.95"	②9.82"
Station Wagon	10.16"	10.41"
Firebird	8.52"	7.90"
Ventura & Phoenix	9.62"	9.56"
Astre & Sunbird	7.75"	7.75"
① - 9.85" on Sedan.		
② - With Hvy. Duty Trailer Pkg. A=10.08", B=10.47"		

CASTER (EXC. ASTRE)

To adjust caster, raise car to remove weight from front wheel and loosen control arm shaft-to-frame bolts. To decrease caster, add shims to front bolt or remove shims from rear bolt. To increase caster, remove shims from front bolt or add shims to rear bolt. Tighten bolts when adjustments are completed.

NOTE - Shim pack should not exceed $\frac{3}{4}$ " thickness or have difference greater than $\frac{3}{8}$ " between front and rear shim packs.

CAMBER (EXC. ASTRE)

To adjust camber, raise car to remove weight from front wheel and loosen control arm shaft-to-frame bolts. To increase camber, remove shims from both front and rear bolts. To decrease camber, add shims to front and rear bolts. By adding or removing equal thickness of shims from front and rear bolts, camber can be changed without changing caster. Tighten bolts

when adjustments are completed. **NOTE** - Shim pack should not exceed $\frac{3}{4}$ " thickness or have difference greater than $\frac{3}{8}$ " between front and rear shim packs.

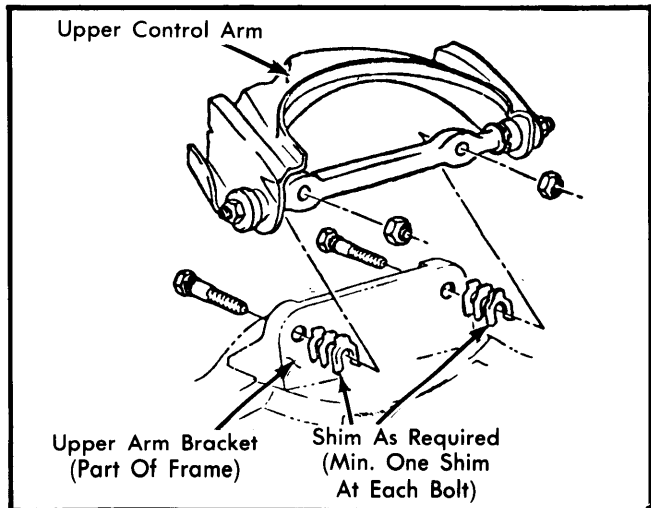

Fig. 28 Pontiac Caster & Camber Adjusting Shims

CASTER (ASTRE)

Loosen rear lower control arm pivot nut and rotate cam until specified caster setting is reached. Tighten pivot nut and check camber setting.

CAMBER (ASTRE)

Loosen front lower control arm pivot nut and rotate cam until specified camber setting is reached. Tighten pivot nut and check caster setting.