

GENERAL MOTORS (Cont.)

caster, rotate front bolt to increase positive camber; if adjusting for excessive positive caster, rotate front bolt to increase negative camber. Rotate rear cam bolt until camber setting returns to 0°. Tighten cam nuts to 95 ft. lbs. and recheck adjustments.

CASTER (SEVILLE)

Loosen nuts and bolts attaching upper control arm to frame. To increase caster (more positive), remove shims from the front bolt and add them to the rear bolt. To decrease caster (more negative), add shims to the front bolt and remove shims from the rear shaft. Tighten control arm shaft nuts to 75 ft. lbs.

NOTE — Difference between front and rear shim packs must not exceed .40 inches.

CAMBER (SEVILLE)

Loosen nuts and bolts attaching upper control arm to frame. To increase camber (more positive), remove shims from both front and rear bolts. To decrease camber (more negative), add equal amount of shims to both front and rear bolts. Tighten control arm shaft nuts to 75 ft. lbs.

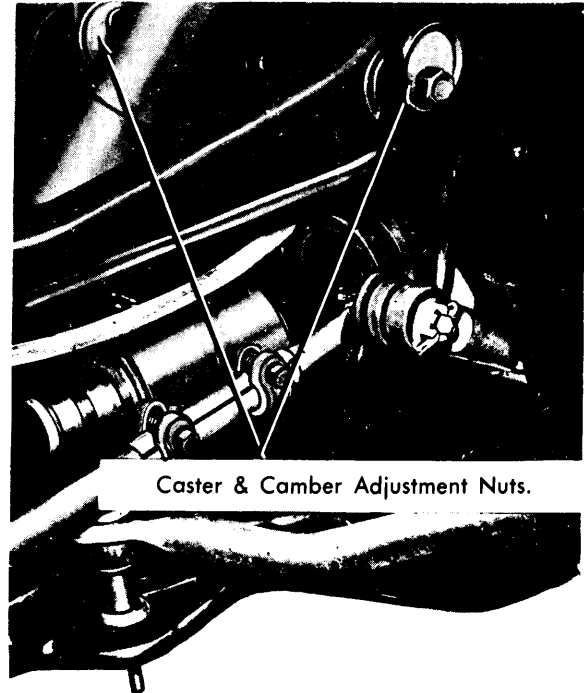

Fig. 11 Eldorado Caster & Camber Cam Locations

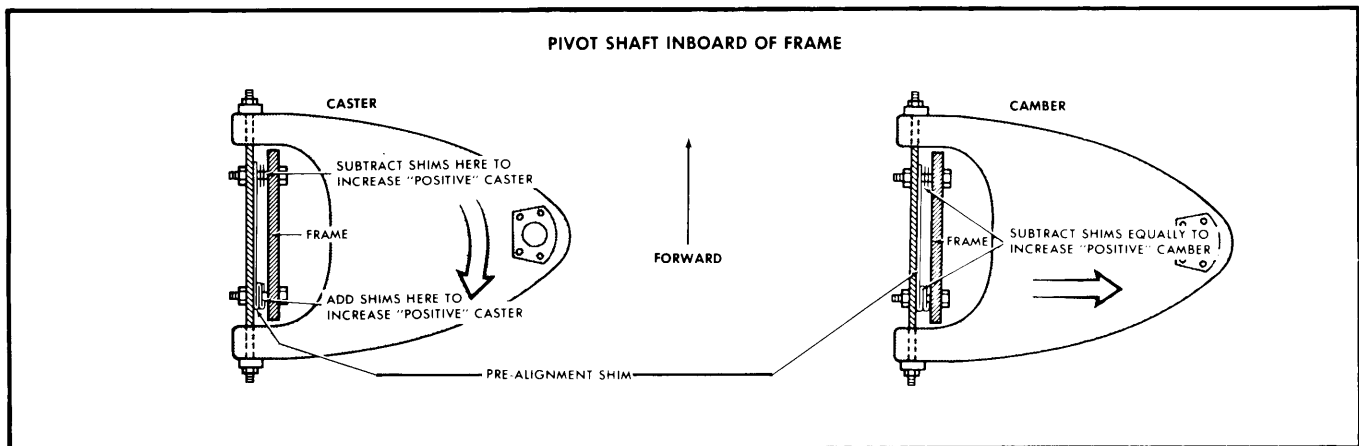

Fig. 12 Caster & Camber Adjustment (Seville)

CHEVROLET

TIRE INFLATION (COLD)

Inflate tires to manufacturers specifications, found on tire inflation placard attached to left front door.

RIDING HEIGHT

With car on smooth level floor, lift car about 1½" at front bumper and allow vehicle to settle on its own. Repeat twice more, then measure the "Z" and "J" height in the settled position after third lift. Repeat procedure and average the readings for true measurement. When measuring "D" and "K" height, follow same procedure except lift and push on rear bumper. Measurements must be within specifications (see specifications table).

Wheel Alignment

GENERAL MOTORS (Cont.)

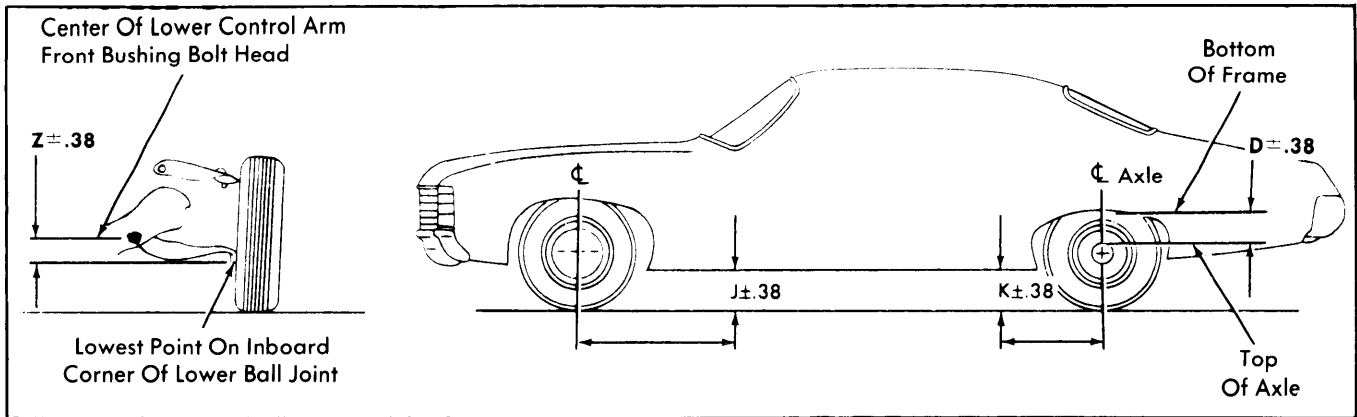

Fig. 13 Riding Height Measuring Points
(Exc. Corvette, Vega, Monza & Chevette)

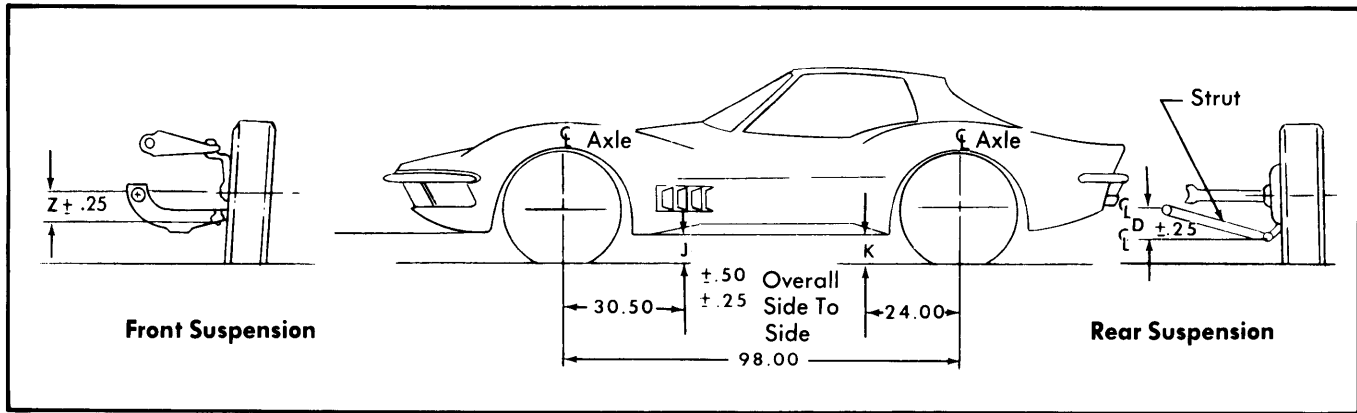

Fig. 14 Riding Height Measuring Points
(Corvette)

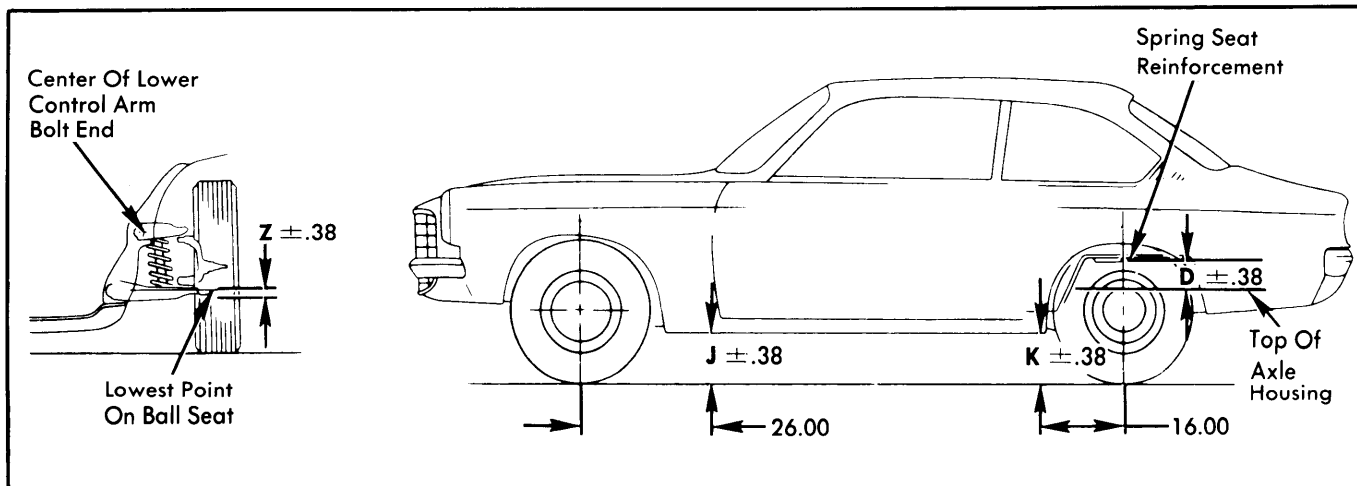

Fig. 15 Riding Height Measuring Points
(Vega & Monza)

GENERAL MOTORS (Cont.)

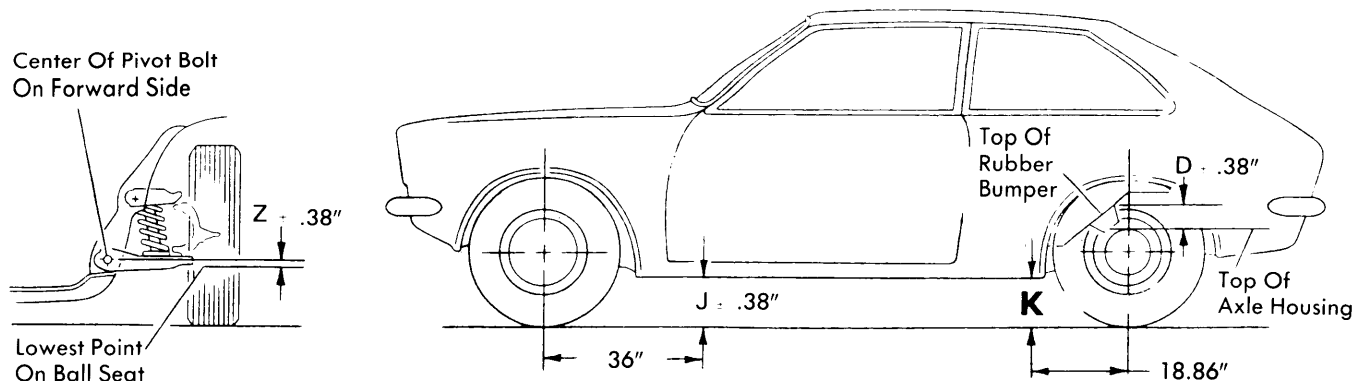

Fig. 16 Riding Height Measuring Points (Chevette)

RIDING HEIGHT SPECIFICATIONS

Application	Tires	Z	J	K	D		
Chevrolet.....	FR-78.....	2.80"	10.51"	10.62"	6.46"		
	GR-78.....	2.44"	10.51"	10.62"	6.10"		
	GR-70.....	2.44"	10.51"	10.62"	6.10"		
	HR-78.....	2.20"	10.55"	10.67"	5.08"		
Chevelle (Without Hvy. Susp.)	Sedan.....	G-78.....	2.52"	10.76"	10.70"	5.50"	
	Coupe.....	G-78.....	2.50"	10.76"	10.72"	5.50"	
	Wagon.....	H-78.....	2.31"	10.97"	11.12"	4.40"	
El Camino.....	G-78.....	2.35"	10.83"	10.90"	4.82"		
Chevelle (With Hvy. Susp.)	Sedan.....	FR-78.....	2.82"	10.76"	10.70"	5.86"	
		GR-78.....	2.67"	10.76"	10.70"	5.60"	
	Coupe.....	FR-78.....	2.82"	10.76"	10.72"	5.86"	
		GR-78.....	2.64"	10.76"	10.72"	5.59"	
Wagon.....	HR-78.....	2.51"	10.97"	11.12"	5.00"		
El Camino.....	GR-78.....	2.47"	10.83"	10.90"	4.90"		
Monte Carlo.....	GR-70.....	1.71"	10.04"	10.22"	5.17"		
Camaro.....	E-78.....	1.87"	8.20"	7.85"	4.58"		
	FR-78.....	2.19"	8.20"	7.85"	4.89"		
Z-28.....	GR-70.....	1.44"	8.20"	7.85"	4.15"		
Corvette.....	All.....	3.06"	8.68"	8.57"	2.53"		
Nova.....	E-78.....	1.65"	9.71"	9.69"	5.62"		
	FR-78.....	1.98"	9.71"	9.69"	5.87"		
Chevette.....	P155-D13.....	2.21"	5.35"	8.98"	9.02"		
	P155-R13.....	2.36"	5.28"	8.86"	8.58"		
Vega	Coupe.....	A-78.....	2.26"	7.75"	7.75"	10.15"	
		A-70.....	2.25"	7.75"	7.75"	10.16"	
		BR-78.....	2.51"	7.75"	7.75"	10.36"	
		BR-70.....	2.39"	7.75"	7.75"	10.31"	
Wagon.....	A-78.....	2.24"	7.75"	7.75"	10.14"		
	A-70.....	2.23"	7.75"	7.75"	10.16"		
	BR-78.....	2.47"	7.75"	7.75"	10.38"		
Monza	Notchback	4 Cyl.....	A-78.....	2.23"	7.75"	7.75"	10.15"
			BR-78.....	2.49"	7.75"	7.75"	10.38"
			BR-70.....	2.39"	7.75"	7.75"	10.30"
	V8.....	BR-70.....	2.32"	7.75"	7.75"	10.09"	
Hatchback	4 Cyl.....	A-78.....	2.28"	7.75"	7.75"	10.14"	
			BR-78.....	2.53"	7.75"	7.75"	10.37"
			BR-70.....	2.43"	7.75"	7.75"	10.28"
	V8.....	BR-70.....	2.35"	7.75"	7.75"	10.08"	

Wheel Alignment

GENERAL MOTORS (Cont.)



Fig. 17 Caster & Camber Adjusting Shims
(Exc. Vega, Monza & Chevette)

CAMBER (EXC. VEGA, MONZA, CORVETTE & CHEVETTE)

Loosen bolts and nuts attaching upper control arm shaft to frame. Adding an equal number of shims at both front and rear bolt will decrease camber while subtracting an equal number of shims will increase camber. Tighten bolts when adjustments are completed. **NOTE**— Normal shim pack will leave at least two threads of bolt exposed beyond nut. Difference between front and rear shim packs must not exceed .40".

CASTER (EXC. VEGA, MONZA, CORVETTE & CHEVETTE)

Loosen bolts and nuts attaching upper control arm shaft to frame. To decrease caster, add shims to front bolt or remove shims from rear bolt. To increase caster, remove shims from front bolt or add shims to rear bolt. Tighten bolts when adjustments are completed. **NOTE**— Normal shim pack will leave at least two threads of bolt exposed beyond nut. Difference between front and rear shim packs must not exceed .40".

CAMBER (VEGA & MONZA)

To adjust, loosen front lower control arm pivot nut and rotate cam until proper setting is achieved. Hold cam bolt head while tightening nut.

CASTER (VEGA & MONZA)

To adjust, loosen rear lower control arm pivot nut and rotate cam until proper setting is obtained. Hold cam bolt head while tightening nut. Recheck camber after setting caster.

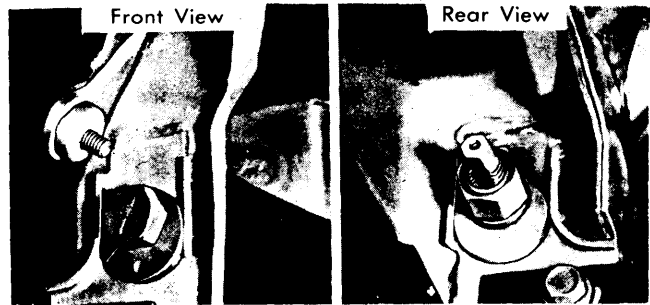

Fig. 18 Vega Caster & Camber Adjustment

CAMBER (CHEVETTE)

Remove upper ball joint, rotate joint one half turn and reinstall with flat surface of upper flange facing inboard side of control arm. This will increase camber angle approximately 1°.

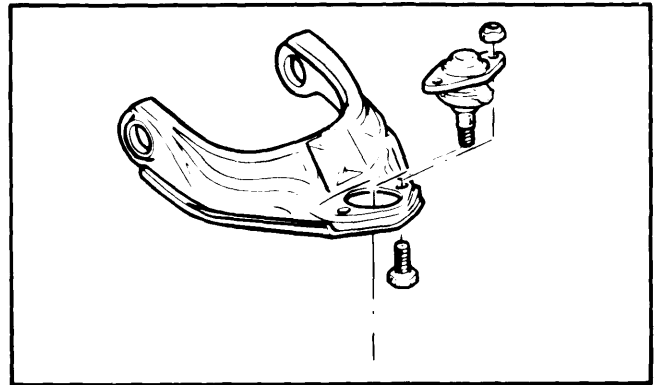

Fig. 19 Chevette Camber Adjustment

CASTER (CHEVETTE)

Adjust caster by realigning washers located between legs of upper control arm. **NOTE**— Always use two washers with a combined thickness of .427" (12 mm).

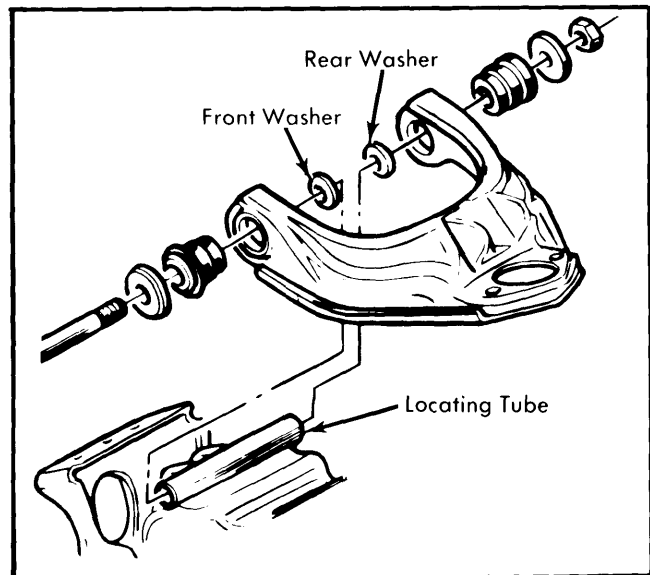

Fig. 20 Chevette Caster Adjustment

GENERAL MOTORS (Cont.)

CASTER (CORVETTE FRONT)

To adjust caster, loosen front and rear bolts of upper control arm support shaft and add or remove shims from either bolt as required. Adding shims at front bolt or removing shims at rear bolt will decrease caster. A $\frac{1}{32}$ " shim will change caster $\frac{1}{2}$ °.

CAMBER (CORVETTE FRONT)

To adjust camber, add or remove shims in equal amounts at both front and rear bolts of upper control arm support shaft. A $\frac{1}{32}$ " shim will vary camber $1/6$ °. After adjustments are completed tighten upper control arm support shaft bolts.

CAMBER (CORVETTE REAR)

Camber adjustments are made by adjusting eccentric cam and bolt assembly located at inboard mounting of strut rod. To change camber setting, loosen locknut on cam bolt and rotate cam and bolt assembly until specified camber is obtained. Tighten locknut.

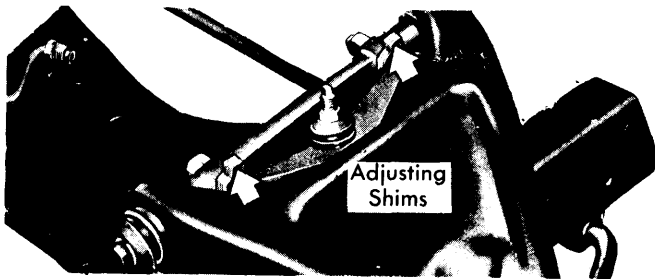

Fig. 21 Corvette Caster & Camber Adjusting Shims (Front)

TOE-IN (CORVETTE REAR)

Rear wheel toe-in angle is adjusted through use of variable thickness shims inserted between torque arm and frame side member web at forward pivoting joint. Shims are slotted to slide over bushing pivot bolt on either side. To adjust, loosen pivot bolt, shim outboard gap as necessary to obtain solid stack-up between outer end of torque arm bushing and inner wall of frame side member, and when adding shims to inner side of control arm do not use thicker shim than necessary or force insertion of shim as this may cause toe-in setting to change. After shims are securely installed, tighten pivot bolt.

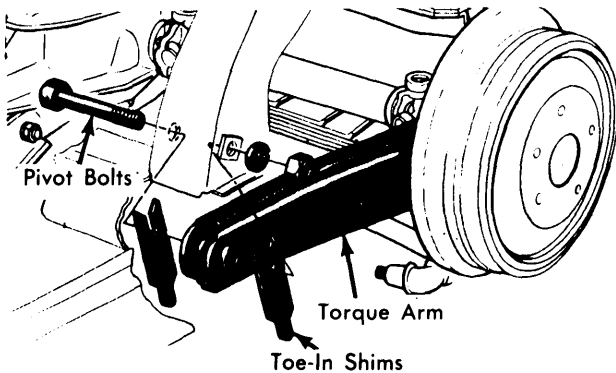

Fig. 22 Corvette Rear Suspension Toe-In Shims

OLDSMOBILE (EXCEPT TORONADO)

TIRE INFLATION (COLD)

Inflate tires to recommended pressures listed on rear of left front door on Omega and Starfire models, and inside glove box door on all other models.

RIDING HEIGHT

Check riding height with full gas tank, front seat rearward, tire pressure correct, doors closed and trunk empty. With vehicle on level floor, bounce several times and allow car to settle. Measure heights as shown in illustration. Measured heights may differ side to side $\pm \frac{3}{4}$ " and front to rear $\pm \frac{3}{4}$ ".

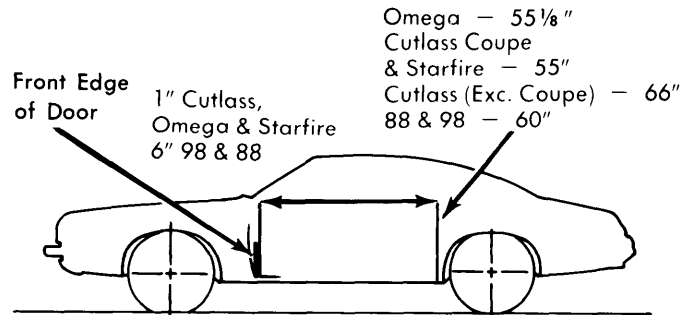

Fig. 23 Riding Height Measuring Points (Oldsmobile Exc. Toronado)

RIDING HEIGHT SPECIFICATIONS

Application	Front	Rear
Starfire	7.75"	7.75"
Omega	9.62"	9.50"
Cutlass (Exc. Wagon) ..	10.38"	10.50"
Cutlass Wagon	10.50"	10.62"
88 & 98	10.00"	10.25"

CASTER (EXC. STARFIRE)

Loosen pivot shaft-to-frame nuts. **CAUTION** — Bolts are splined to frame and should not be turned. To decrease positive caster (increase negative caster), add shims at front bolt. To increase positive caster (decrease negative caster), remove shims at front bolt.

CAMBER (EXC. STARFIRE)

Loosen pivot shaft-to-frame nuts. **CAUTION** — Bolts are splined to frame and should not be turned. To increase positive camber, remove shims at both front and rear bolts. To decrease positive camber, add shims at both front and rear bolts. **NOTE** — By adding or subtracting an equal amount of shims from front and rear bolts, camber can be changed without affecting caster adjustment.