

Wheel Alignment

GENERAL MOTORS (Cont.)

CADILLAC

TIRE INFLATION (COLD)

Before checking wheel alignment, ensure that tires are inflated to manufacturers specifications, found on tire placard in glove box.

RIDING HEIGHT

Before checking riding height, trunk must be empty (except for spare tire and jack), front seat all way to rear, and fuel tank full. Normalize springs by working bumper up and down, then release bumper and let car assume normal position. If car is equipped with Automatic Level Control, deflate system using service valve and disconnect air line from superlift port on control valve. Check riding height as follows:

Front (Exc. Eldorado & Seville) — Measure distance from top of lower control arm in front of rubber bumper to flat surface on bottom of frame. Distance should be within specifications, and equal within $\frac{3}{8}$ " from side to side. If heights are unequal, replace spring on low side.

Front (Eldorado) — Measure distance from lower edge of front shock absorber dust tube to centerline of lower attachment. Distance should be within specifications, and equal within $\frac{3}{8}$ " on each side. If not within specifications adjust at torsion bar adjusting bolt. Clockwise rotation of bolt increases front height while counterclockwise rotation decreases height.

Front (Seville) — Measure distance from center of lower control arm bushing bolt head to horizontal line from lowest point on inboard corner of lower ball joint. Distance should be within specification and equal from side to side within $\frac{3}{8}$ ". If heights are not equal, replace spring on low side.

Rear (All Models) — Measure distance from top of axle housing straight up to lower underside of frame. Distance should be within specifications, and equal within $\frac{1}{2}$ " on each side. If not within specifications, replace spring on low side.

RIDING HEIGHT SPECIFICATIONS

Application	Front	Rear
Coupe DeVille	2.12-2.87"	①5.76-6.51"
Sedan DeVille	2.12-2.87"	①5.76-6.51"
Brougham	1.86-2.61"	5.38-6.13"
Fleetwood	1.84-2.59"	5.38-6.13"
Eldorado	8.19-8.44"	4.82-5.57"
Seville	2.12-2.50"	②3.50-4.12"

① — With ALC 5.38-6.13"
② — With ALC Disconnected, 3.50"

CASTER (EXC. ELDORADO & SEVILLE)

NOTE — Before adjusting caster, loosen tie-struts at lower suspension arms to allow tie-strut to center and thus prevent damage to bushings and premature wear at frame front crossmember. To provide more negative caster, lengthen tie-struts by loosening front lock nuts and tightening rear lock nuts. To provide more positive caster, shorten tie-struts by loosening rear lock nuts and tightening front lock nuts. One turn of lock nuts results in approximately $\frac{1}{2}$ ° change in caster. After adjustments are made, tighten tie-strut mounting bolt nuts at lower arms to 55 ft. lbs. and front lock nuts to 35 ft. lbs.

NOTE — When tightening front lock nut, hold rear nut securely to prevent changing caster setting.

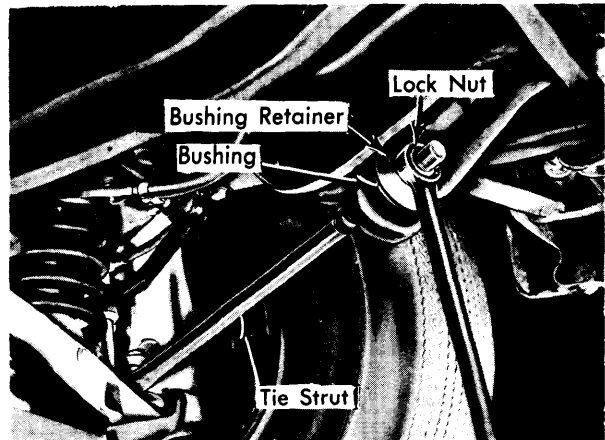

Fig. 9 Caster Adjustment (Exc. Eldorado & Seville)

CAMBER ADJUSTMENT (EXC. ELDORADO & SEVILLE)

Loosen lock nut on ball joint stud one turn and strike steering knuckle to free camber eccentric in steering knuckle. Using suitable tool (J-23415) turn camber eccentric until desired camber is obtained. Final position of ball joint should be in rear portion of camber eccentric in order to keep steering arm angle correct. After adjustments are completed, tighten ball joint stud nut.



Fig. 10 Camber (Exc. Eldorado & Seville)

CAMBER & CASTER (ELDORADO)

Loosen nuts on upper control arm front and rear cam bolts, note camber reading. Rotate front bolt to correct for half of incorrect reading. Rotate rear bolt to bring camber reading to 0°, then tighten front and rear cam bolts. Check caster and if no adjustment necessary, tighten cam nuts to 95 ft. lbs. If caster adjustment necessary, loosen front and rear cam bolts and rotate front bolt so camber changes an amount equal to $\frac{1}{4}$ of desired caster change. If adjusting for excessive negative

GENERAL MOTORS (Cont.)

caster, rotate front bolt to increase positive camber; if adjusting for excessive positive caster, rotate front bolt to increase negative camber. Rotate rear cam bolt until camber setting returns to 0°. Tighten cam nuts to 95 ft. lbs. and recheck adjustments.

CASTER (SEVILLE)

Loosen nuts and bolts attaching upper control arm to frame. To increase caster (more positive), remove shims from the front bolt and add them to the rear bolt. To decrease caster (more negative), add shims to the front bolt and remove shims from the rear shaft. Tighten control arm shaft nuts to 75 ft. lbs.

NOTE — Difference between front and rear shim packs must not exceed .40 inches.

CAMBER (SEVILLE)

Loosen nuts and bolts attaching upper control arm to frame. To increase camber (more positive), remove shims from both front and rear bolts. To decrease camber (more negative), add equal amount of shims to both front and rear bolts. Tighten control arm shaft nuts to 75 ft. lbs.

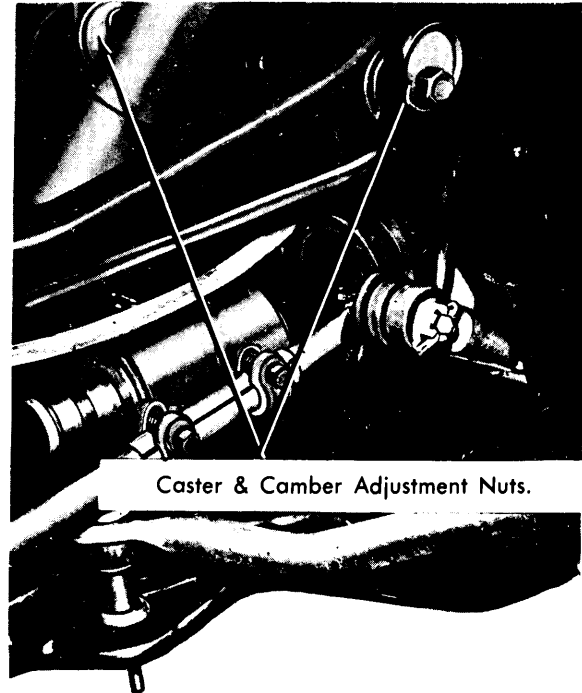

Fig. 11 Eldorado Caster & Camber Cam Locations

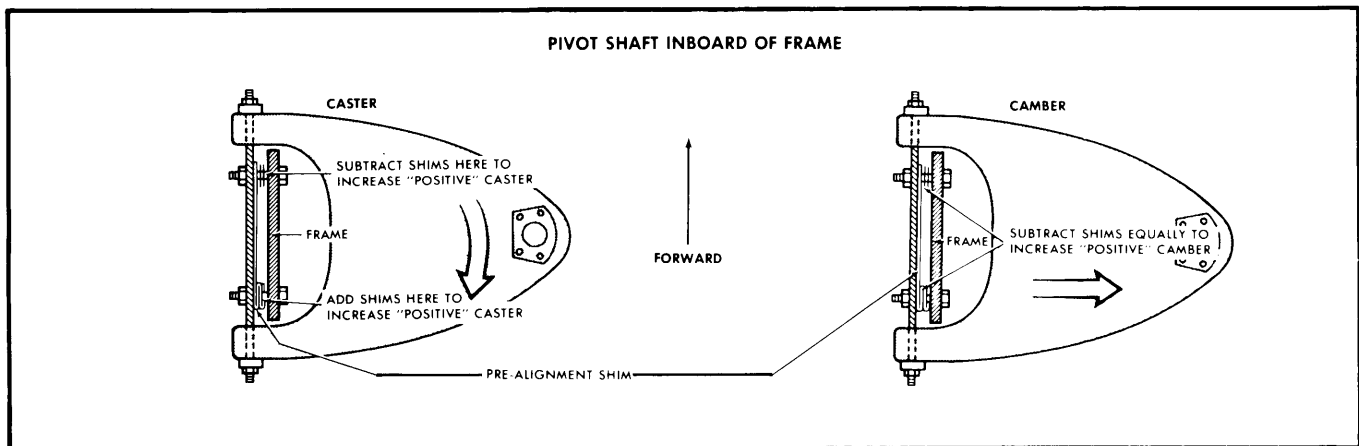

Fig. 12 Caster & Camber Adjustment (Seville)

CHEVROLET

TIRE INFLATION (COLD)

Inflate tires to manufacturers specifications, found on tire inflation placard attached to left front door.

RIDING HEIGHT

With car on smooth level floor, lift car about 1½" at front bumper and allow vehicle to settle on its own. Repeat twice more, then measure the "Z" and "J" height in the settled position after third lift. Repeat procedure and average the readings for true measurement. When measuring "D" and "K" height, follow same procedure except lift and push on rear bumper. Measurements must be within specifications (see specifications table).

Wheel Alignment

GENERAL MOTORS (Cont.)

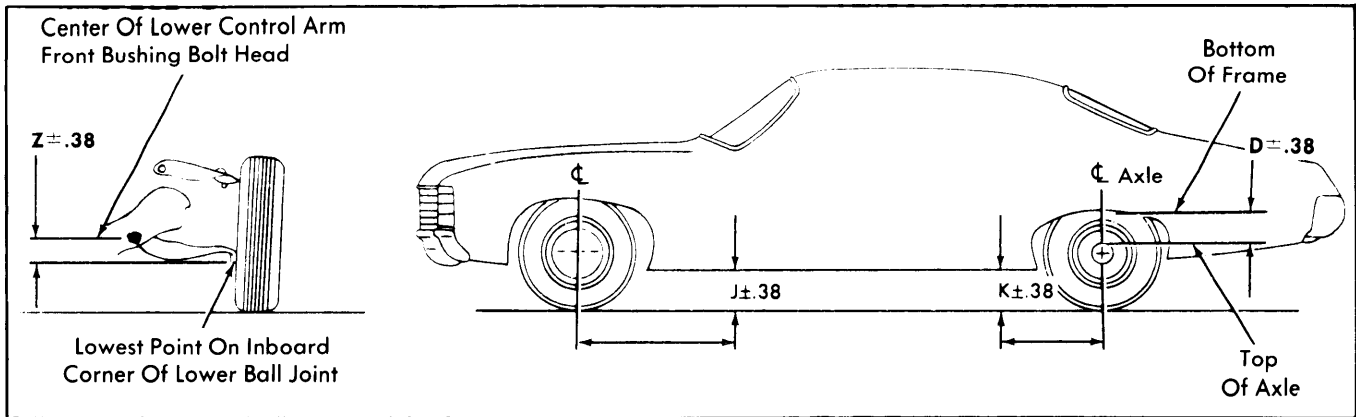

Fig. 13 Riding Height Measuring Points
(Exc. Corvette, Vega, Monza & Chevette)

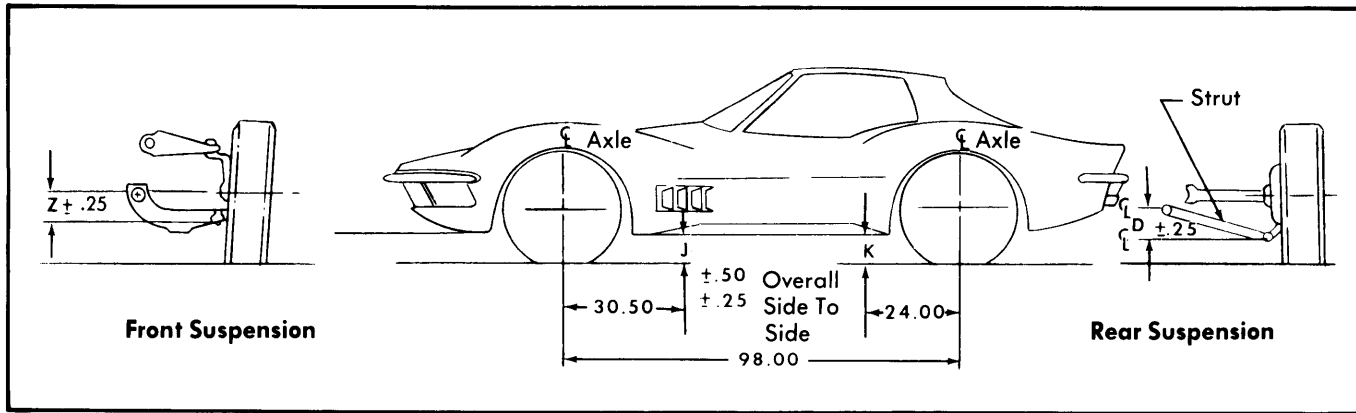

Fig. 14 Riding Height Measuring Points
(Corvette)

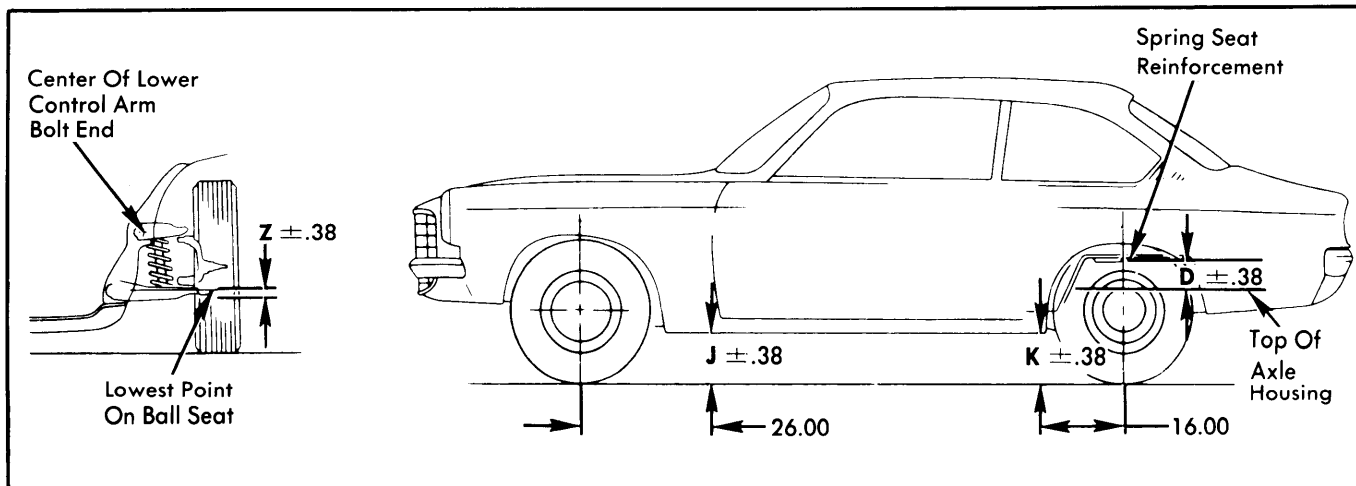

Fig. 15 Riding Height Measuring Points
(Vega & Monza)

GENERAL MOTORS (Cont.)

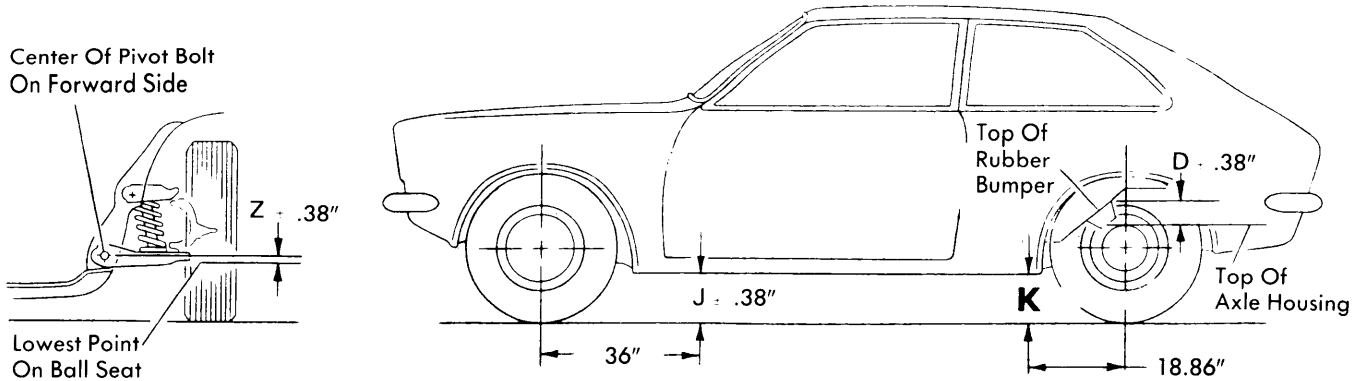

Fig. 16 Riding Height Measuring Points (Chevette)

RIDING HEIGHT SPECIFICATIONS

Application	Tires	Z	J	K	D		
Chevrolet.....	FR-78.....	2.80"	10.51"	10.62"	6.46"		
	GR-78.....	2.44"	10.51"	10.62"	6.10"		
	GR-70.....	2.44"	10.51"	10.62"	6.10"		
	HR-78.....	2.20"	10.55"	10.67"	5.08"		
Chevelle (Without Hvy. Susp.)	Sedan.....	G-78.....	2.52"	10.76"	10.70"	5.50"	
	Coupe.....	G-78.....	2.50"	10.76"	10.72"	5.50"	
	Wagon.....	H-78.....	2.31"	10.97"	11.12"	4.40"	
El Camino.....	G-78.....	2.35"	10.83"	10.90"	4.82"		
Chevelle (With Hvy. Susp.)	Sedan.....	FR-78.....	2.82"	10.76"	10.70"	5.86"	
		GR-78.....	2.67"	10.76"	10.70"	5.60"	
	Coupe.....	FR-78.....	2.82"	10.76"	10.72"	5.86"	
		GR-78.....	2.64"	10.76"	10.72"	5.59"	
Wagon.....	HR-78.....	2.51"	10.97"	11.12"	5.00"		
El Camino.....	GR-78.....	2.47"	10.83"	10.90"	4.90"		
Monte Carlo.....	GR-70.....	1.71"	10.04"	10.22"	5.17"		
Camaro.....	E-78.....	1.87"	8.20"	7.85"	4.58"		
	FR-78.....	2.19"	8.20"	7.85"	4.89"		
Z-28.....	GR-70.....	1.44"	8.20"	7.85"	4.15"		
Corvette.....	All.....	3.06"	8.68"	8.57"	2.53"		
Nova.....	E-78.....	1.65"	9.71"	9.69"	5.62"		
	FR-78.....	1.98"	9.71"	9.69"	5.87"		
Chevette.....	P155-D13.....	2.21"	5.35"	8.98"	9.02"		
	P155-R13.....	2.36"	5.28"	8.86"	8.58"		
Vega	Coupe.....	A-78.....	2.26"	7.75"	7.75"	10.15"	
		A-70.....	2.25"	7.75"	7.75"	10.16"	
		BR-78.....	2.51"	7.75"	7.75"	10.36"	
		BR-70.....	2.39"	7.75"	7.75"	10.31"	
Wagon.....	A-78.....	2.24"	7.75"	7.75"	10.14"		
	A-70.....	2.23"	7.75"	7.75"	10.16"		
	BR-78.....	2.47"	7.75"	7.75"	10.38"		
Monza	Notchback	4 Cyl.....	A-78.....	2.23"	7.75"	7.75"	10.15"
			BR-78.....	2.49"	7.75"	7.75"	10.38"
			BR-70.....	2.39"	7.75"	7.75"	10.30"
		V8.....	BR-70.....	2.32"	7.75"	7.75"	10.09"
Hatchback	4 Cyl.....	A-78.....	2.28"	7.75"	7.75"	10.14"	
		BR-78.....	2.53"	7.75"	7.75"	10.37"	
		BR-70.....	2.43"	7.75"	7.75"	10.28"	
		V8.....	BR-70.....	2.35"	7.75"	7.75"	10.08"

Wheel Alignment

GENERAL MOTORS (Cont.)



Fig. 17 Caster & Camber Adjusting Shims
(Exc. Vega, Monza & Chevette)

CAMBER (EXC. VEGA, MONZA, CORVETTE & CHEVETTE)

Loosen bolts and nuts attaching upper control arm shaft to frame. Adding an equal number of shims at both front and rear bolt will decrease camber while subtracting an equal number of shims will increase camber. Tighten bolts when adjustments are completed. **NOTE**— Normal shim pack will leave at least two threads of bolt exposed beyond nut. Difference between front and rear shim packs must not exceed .40".

CASTER (EXC. VEGA, MONZA, CORVETTE & CHEVETTE)

Loosen bolts and nuts attaching upper control arm shaft to frame. To decrease caster, add shims to front bolt or remove shims from rear bolt. To increase caster, remove shims from front bolt or add shims to rear bolt. Tighten bolts when adjustments are completed. **NOTE**— Normal shim pack will leave at least two threads of bolt exposed beyond nut. Difference between front and rear shim packs must not exceed .40".

CAMBER (VEGA & MONZA)

To adjust, loosen front lower control arm pivot nut and rotate cam until proper setting is achieved. Hold cam bolt head while tightening nut.

CASTER (VEGA & MONZA)

To adjust, loosen rear lower control arm pivot nut and rotate cam until proper setting is obtained. Hold cam bolt head while tightening nut. Recheck camber after setting caster.

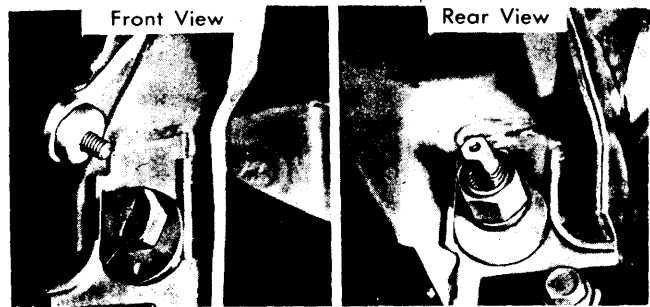

Fig. 18 Vega Caster & Camber Adjustment

CAMBER (CHEVETTE)

Remove upper ball joint, rotate joint one half turn and reinstall with flat surface of upper flange facing inboard side of control arm. This will increase camber angle approximately 1°.

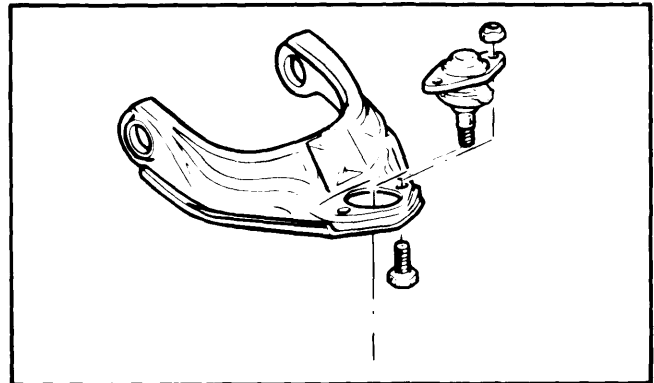

Fig. 19 Chevette Camber Adjustment

CASTER (CHEVETTE)

Adjust caster by realigning washers located between legs of upper control arm. **NOTE**— Always use two washers with a combined thickness of .427" (12 mm).

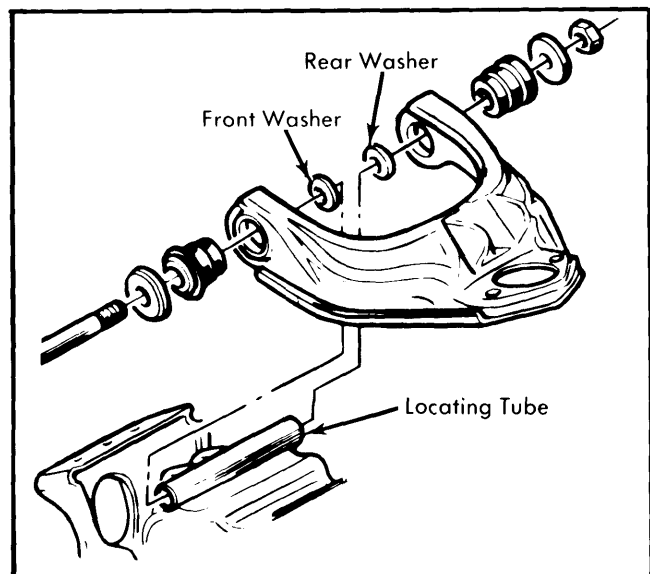

Fig. 20 Chevette Caster Adjustment