

Wheel Bearing Adjustment

ALL CAR MODELS

ADJUSTMENT

NOTE — Correct wheel bearing adjustment is very important on vehicles with disc brakes as too much endplay in bearings will cause disc wobble and brake damage.

NOTE — On all cars with disc brakes, caliper assembly must be removed before disc and hub to work on wheel bearings. Caliper-to-disc clearance is very critical on some cars. Be sure to observe all cautions. It is not necessary to disconnect brake lines to remove caliper assembly. Wire caliper assembly up out of way (do not hang from brake line).

AMERICAN MOTORS

All Models — Tighten spindle nut to 22 ft. lbs. while rotating wheel. Loosen spindle nut $\frac{1}{3}$ turn, with wheel rotating, retorque spindle nut to 6 INCH lbs. Place nut retainer on spindle nut with slots of retainer aligned with cotter pin hole on spindle. Install cotter pin and dust cap.

CHRYSLER CORP.

Tighten wheel bearing adjusting nut to 240-300 INCH lbs. while rotating wheel. Back off adjusting nut until preload is released, tighten adjusting nut finger tight and install lock nut and cotter pin. The resulting adjustment should be .001-.003" end play.

FORD MOTOR CO.

All Models — Rotate wheel, hub, (& rotor on disc brake) torque adjusting nut to 17-25 ft. lbs. Back off nut $\frac{1}{2}$ turn. Retighten adjusting nut to 10-15 INCH lbs. Install cotter pin.

GENERAL MOTORS

Buick — Spin wheel and snug spindle nut to seat bearing. Back off nut until just loose ($\frac{1}{4}$ - $\frac{1}{2}$ turn). Hand snug spindle nut, loosen nut $\frac{1}{12}$ to $\frac{1}{6}$ turn and insert cotter pin. Endplay should be .001-.005".

Cadillac (Except Eldorado) — Tighten adjusting nut to 15 ft. lbs. while rotating wheel. Back off spindle nut one flat and retighten finger tight. If slot and hole not aligned, loosen adjusting nut until cotter pin can be installed.

Cadillac Eldorado (Front Wheel) — When installing hub assembly, tighten nut to 110 ft. lbs. Tighten nut to next slot if necessary, to install cotter pin. **NOTE** — No bearing adjustment necessary.

Cadillac Eldorado (Rear Wheel) — While rotating hub assembly, tighten spindle nut to 25-30 ft. lbs. Then back off nut $\frac{1}{2}$ turn, retighten to 2 ft. lbs. Install cotter pin, if necessary to make holes align, back off nut until cotter pin may be inserted.

Chevrolet — While rotating wheel, snug nut to 12 ft. lbs. to fully seat bearings. Back off nut until loose. Snug nut up by hand, loosen until either hole in spindle lines up with slot in nut and insert cotter pin. Endplay should be .001-.005".

Oldsmobile (Except Toronado) — Tighten spindle nut to 30 ft. lbs. while rotating wheel. Back off nut $\frac{1}{2}$ turn and retighten finger tight. Insert cotter pin. Back off no more than $\frac{1}{24}$ turn if necessary, to install cotter pin.

Oldsmobile Toronado (Front Wheel) — Not a bearing adjustment. When installing hub assembly, tighten nut to 140 ft. lbs. Tighten nut to next slot if necessary, to install cotter pin.

Oldsmobile Toronado (Rear Wheel) — Same as standard Oldsmobile front wheel bearing adjustment (see above).

Pontiac — Snug up nut to fully seat bearings. Back off nut until just loose ($\frac{1}{4}$ - $\frac{1}{2}$ turn). Snug nut up by hand, loosen until hole in spindle lines up with slot in nut and install cotter pin. Endplay should be .001-.005".

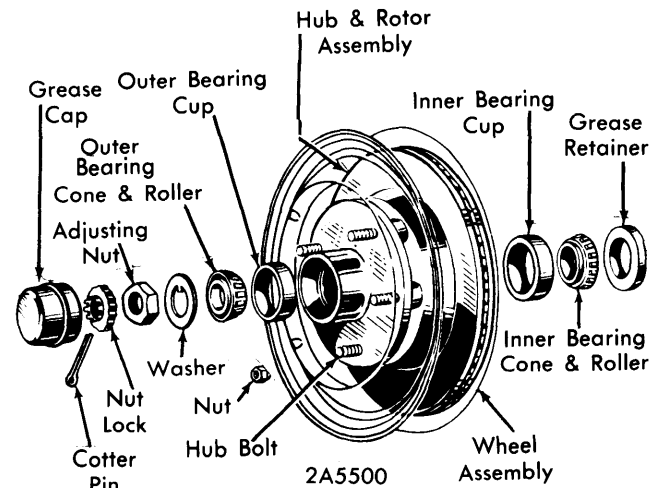

WHEEL BEARING EXPLODED VIEW (TYPICAL)