

Wheel Alignment

WHEEL ALIGNMENT SPECIFICATIONS & ADJUSTMENT

ADJUSTMENT CAUTIONS

Before making front end alignment adjustments, check the following points:

- 1) Wheel bearings must be properly adjusted.
- 2) Steering linkage and suspension must not have excessive looseness. Check for wear in tie rod ball ends and ball joints.
- 3) Tires should be approximately equal in tread wear and runout must not be excessive. Tires and wheels should be in balance and inflated to manufacturers specifications.
- 4) Car must be at curb height with full fuel tank, no passenger load, spare tire in place but no load in trunk.
- 5) Car must be on level floor and at normal running height. Bounce front end of car several times and allow it to settle to running height.
- 6) If steering wheel not centered with front wheels in straight ahead position, correct by shortening one tie rod adjusting sleeve and lengthening opposite sleeve.
- 7) Ensure wheel lug nuts are tightened to manufacturers specifications as shown in following table.

WHEEL LUG NUTS TIGHTENING SPECIFICATIONS	
Application	Ft. Lbs.
American Motors	75
Buick	
Century, Skyhawk.....	70
All Others	90
Cadillac	
Seville.....	80
All Others	100
Chevrolet	
Impala, Caprice.....	80-100
All Others	60-80
Chrysler Corp	
Valiant, Dart, Aspen, Volare	55
All Others	65
Ford Motor Co.....	95
Oldsmobile	
88 & 98.....	100
Toronado.....	130
All Others	80
Pontiac	
Catalina, Bonneville.....	75
All Others	70

TOE-IN ADJUSTMENT

Measure toe-in with front wheels in straight ahead position and steering wheel centered. Adjust toe-in by loosening clamps and turning adjusting sleeve or adjustable end on right and left hand tie rods equally and in opposite directions to maintain steering wheel in centered position. **CAUTION** — Face of tie rod end must be parallel with machined surface of steering rod end to prevent cocking and binding of the ball end in service. When tightening clamps, make certain that clamp bolts are positioned so there will be no interference with other parts throughout entire travel of the linkage.

TOE-OUT ON TURNS

This is a check for bent or damaged parts and not a service adjustment. With caster, camber, and toe-in properly adjusted, check toe-out with weight of car on wheels (use full-floating turn table under each wheel), repeating test with each wheel position for right and left turn. Incorrect toe-out generally indicates a bent steering arm. Replace arm and recheck all front end adjustments. **CAUTION** — Do not attempt to correct by straightening parts.

STEERING AXIS INCLINATION

This is a check for bent or damaged parts and not a service adjustment. Car must be level (crosswise and lengthwise) and camber should be within limits. If camber cannot be brought within limits and steering axis inclination is correct, steering knuckle is bent. If camber and steering axis inclination are incorrect by approximately the same amount, upper or lower control arms are bent. Replace parts and recheck all front end adjustments. **CAUTION** — Do not attempt to correct by straightening parts.

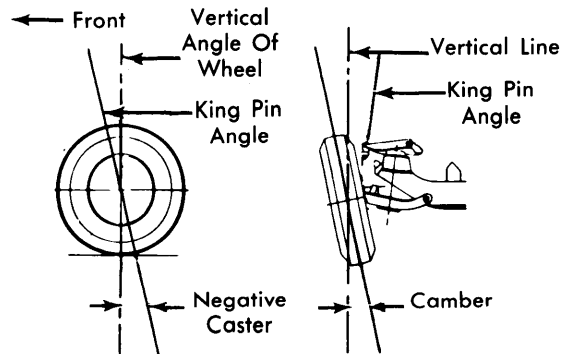

3A229

WHEEL ALIGNMENT ANGLES