

BENDIX SINGLE PISTON DISC

American Motors
Ford Motor Co.

DESCRIPTION

The disc brake unit consists of a rotor, a single piston caliper assembly, two shoe and lining assemblies, a caliper anchor plate and a splash shield. The cast iron rotor has integrally cast cooling fins between the two braking surfaces. The sliding-type caliper assembly is positioned in, and slides on, machined surfaces on the leading and trailing edges of the caliper anchor plate. Brake linings are riveted to the brake shoes and insulator gaskets are bonded to the back of each brake shoe. On Ford Motor Co. vehicles equipped with four wheel disc brakes, a parking brake mechanism is incorporated into the rear calipers and is cable actuated.

NOTE — Front disc brakes are standard on most vehicles except for the following models which have disc brakes as optional equipment: American Motors Pacer, Gremlin and Hornet; Ford Motor Co. Comet and Maverick. Ford Motor Co. four wheel disc brakes are standard on Continental Mark IV optional on Ford, Mercury, Thunderbird, Continental, Granada and Monarch.

ADJUSTMENT

SERVICE BRAKES

Disc brakes are self-adjusting. Caliper piston seals are designed to retract pistons just enough to allow brake lining to lightly brush rotor without any drag.

PARKING BRAKE (REAR DISC BRAKES)

Piston Adjustment — Parking brake is self-adjusting. An automatic adjuster in the piston moves on thrust screw to compensate for lining wear and maintain proper clearance in parking brake mechanism.

Cable Adjustment — With parking brake fully released and transmission in neutral, raise and support vehicle. Tighten parking brake cable adjuster nut until levers on calipers just begin to move, then loosen nut until levers just return to the full stop position. Apply parking brake several times and ensure levers are fully returned to the stop by attempting to pull them rearward. If lever moves rearward, adjustment is too tight. Repeat adjustment procedure. **NOTE** — If levers do not return to stop, function of parking and service brakes will be affected.

SERVICING

BLEEDING SYSTEM

See Hydraulic Brake Bleeding in this section.

SHOE & LINING INSPECTION

Inspect condition of lining any time wheel and tire is removed. On American Motors vehicles, replace lining if thickness of lining is less than thickness of metal shoe. On Ford Motor Co. vehicles, replace lining if worn to less than $\frac{1}{8}$ " thick.

SHOE & LINING REPLACEMENT

Removal (Front) — Drain two-thirds of brake fluid from master cylinder. Raise and support vehicle, and remove front wheel. Bottom caliper piston in bore by inserting a screwdriver between inner shoe and piston and prying piston back into

bore. Remove caliper support key screw. Using a soft metal punch and hammer, remove support key and spring. Lift caliper assembly from anchor plate and rotor. Remove inner shoe and lining from anchor plate and remove anti-rattle spring from inner shoe. Tap lightly on outer shoe to free it from caliper. Support caliper assembly to prevent damage to brake hose.

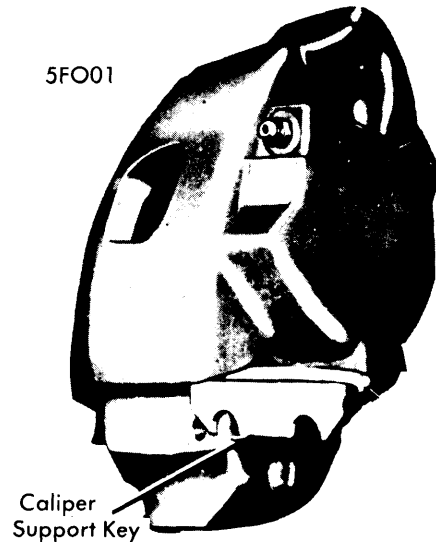

INSTALLING CALIPER SUPPORT KEY

Installation (Front) — To install, reverse removal procedure and note the following: Lubricate caliper and anchor plate sliding surfaces with a suitable lubricant. Ensure anti-rattle spring is properly installed on inner shoe; looped section of spring away from rotor. Fill master cylinder to correct level and depress brake pedal several times to position caliper and brake shoe assemblies on rotor.

Removal (Rear) — 1) Drain two-thirds of brake fluid from master cylinder. Raise and support vehicle, and remove rear wheels. Disconnect parking brake cable from lever on caliper. Remove support key retaining screw, and using a soft metal punch and hammer, remove support key and spring. Lift caliper assembly from anchor plate and rotor.

2) If rotor wear or scoring prevents caliper removal, it will be necessary to bottom piston in caliper bore. To bottom piston, remove parking brake lever from caliper and loosen caliper end retainer a maximum of one-half turn. **CAUTION** — If end retainer is loosened more than one-half turn, seal between thrust screw and housing may be damaged. Force piston back into bore and remove caliper assembly from anchor plate and rotor.

3) Remove inner shoe from anchor plate. If anti-rattle spring is displaced from anchor plate during inner shoe removal, reposition it on plate with loop to inside of anchor plate. Tap lightly on outer shoe to free it from caliper. Support caliper assembly to eliminate strain on brake hose.

Installation (Rear) — 1) If caliper end retainer has been loosened, install caliper assembly (less brake shoes) on anchor plate and tighten end retainer to specifications. Install parking brake lever on caliper and tighten retainer screw. **NOTE** — Lever arm must point down and to the rear. Remove caliper assembly from anchor plate and rotor.

Brake Systems

BENDIX SINGLE PISTON DISC (Cont.)

2) If caliper end retainer was not loosened, it will be necessary to screw piston back into bore. To bottom piston, remove rotor and install caliper assembly (less brake shoes) on anchor plate. Using suitable tool (T75P-2588-B), screw piston into bore until it is fully bottomed. *NOTE — Piston will continue to turn even after it is fully bottomed.* Remove caliper from anchor plate and install rotor.

3) Install new brake shoes (if required) and all related parts in reverse order of removal procedure, noting the following: Lubricate caliper and anchor plate sliding surfaces with a suitable lubricant. With caliper and shoe assemblies installed over rotor, but not secured to anchor plate, pull caliper outward until inner shoe is firmly seated against rotor. With caliper in this position, measure clearance between outer shoe and rotor. Clearance must be .063" or less. If clearance is greater than specified, remove caliper and readjust piston outward until correct clearance is obtained. Fill master cylinder to correct level and depress brake pedal several times to position caliper and shoe assemblies on rotor. Adjust parking brake cable tension (if necessary).

ROTOR SERVICING

Lateral Runout — Tighten wheel bearing adjusting nut until all end play is removed. Mount a dial indicator on a pedestal-type stand or on axle spindle with indicator pointer contacting braking surface one inch from edge of rotor. Turn rotor through one complete revolution, checking indicator reading as rotor moves. If runout exceeds specifications, replace or refinish rotor as necessary.

Parallelism — Measure thickness of rotor at four or more points around rotor. Make all measurements at same distance from edge of rotor. If rotor does not meet specifications, replace or refinish rotor as necessary.

REMOVAL & INSTALLATION

BRAKE CALIPER

Caliper removal and installation procedures are same as for brake shoe assembly replacement, except it will be necessary to disconnect brake hose. See *Shoe & Lining Replacement*.

HUB & ROTOR

Removal (Front) — Raise and support vehicle, and remove wheel. Remove caliper assembly and support out of way to avoid putting a strain on brake hose. Remove grease cap from hub, then remove cotter key, nut lock, adjusting nut and thrust washer from spindle. Pull hub and rotor assembly out far enough to remove outer wheel bearing, then pull hub and rotor assembly from spindle.

Installation (Front) — To install, reverse removal procedure and adjust wheel bearings. See *Wheel Bearing Adjustment in WHEEL ALIGNMENT Section*.

Removal (Rear) — Raise and support vehicle, and remove wheel. Remove caliper assembly and support out of way to avoid putting a strain on brake hose. *NOTE — If both rear rotors are to be removed, mark hat section of rotors to distinguish right from left; rotor are not interchangeable.* Remove the two retainer nuts and remove rotor from axle shaft.

Installation (Rear) — To install, reverse removal procedure and ensure that vanes on outer edge of rotor are pointing in direction of forward rotation.

OVERHAUL

BRAKE CALIPER

Disassembly (Front) — With caliper assembly removed from vehicle, pad interior of caliper with shop cloths. Apply compressed air to fluid inlet port of caliper to remove piston. *NOTE — If piston is seized and cannot be forced from caliper, lightly tap around piston while applying air pressure.* Remove dust boot and pry piston seal from caliper bore.

Cleaning & Inspection (Front) — Clean all parts with denatured alcohol or clean brake fluid and dry with compressed air. Clean out and dry all grooves and passages with compressed air. Inspect piston and caliper bore for wear, pitting, scoring, nicks or corrosion and replace as necessary. *NOTE — On American Motor vehicles, light corrosion can be removed with a fiber brush.*

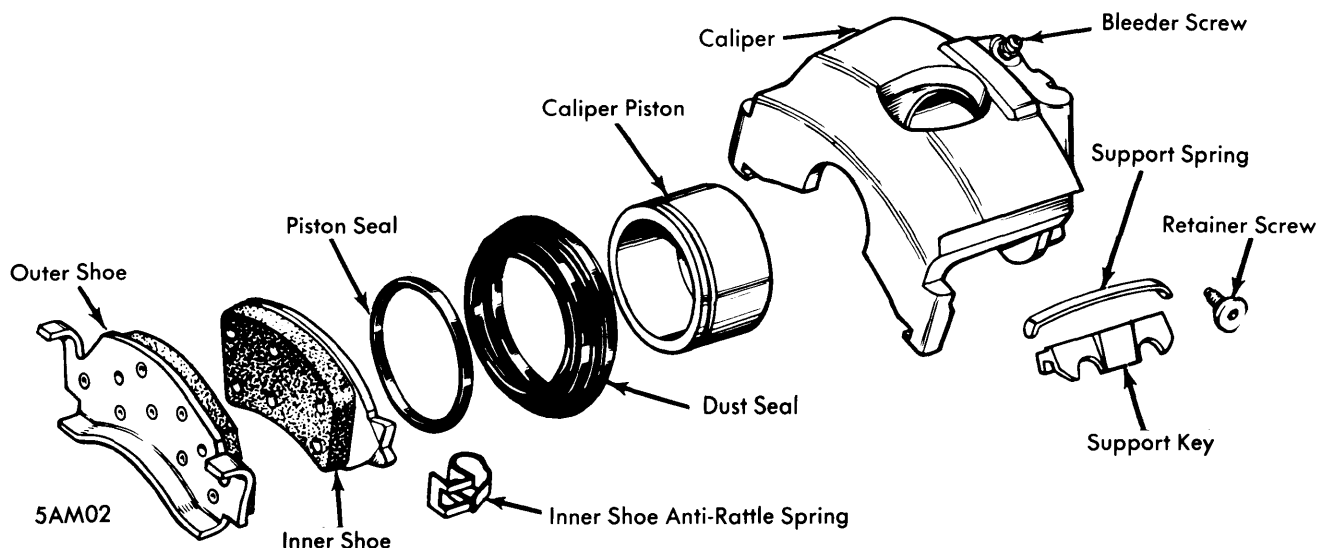

FRONT CALIPER ASSEMBLY (AMERICAN MOTORS SHOWN)

BENDIX SINGLE PISTON DISC (Cont.)

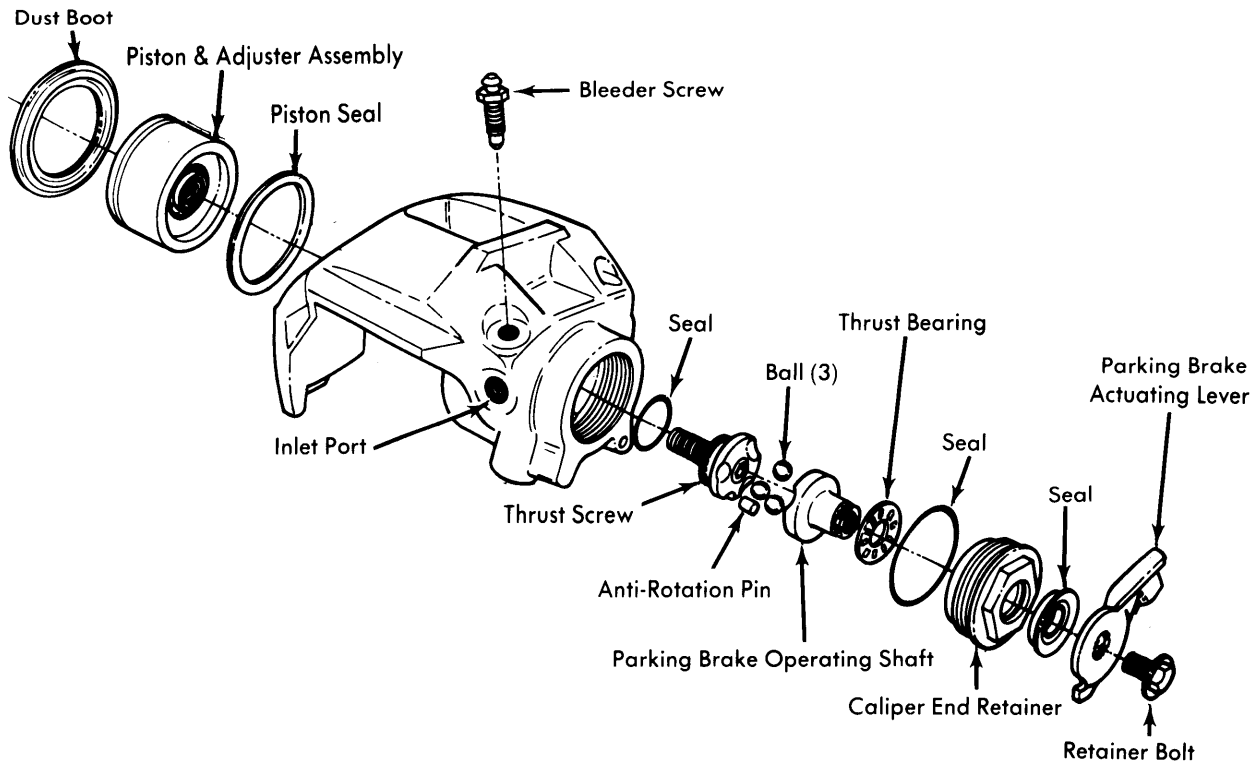

5FO03

REAR CALIPER ASSEMBLY (FORD MOTOR CO.)

Reassembly (Front) — Apply a film of clean brake fluid to new piston seal and dust boot and install into caliper bore. Coat piston with clean brake fluid and install into caliper bore. *NOTE* — Spread dust boot over piston as it is installed. Seat dust boot in piston groove.

Disassembly (Rear) — 1) With caliper removed from vehicle, remove caliper end retainer. Lift out operating shaft, thrust bearing and balls. Remove thrust screw anti-rotation pin with a magnet or tweezers. If anti-rotation pin cannot be removed with magnet or tweezers, adjust piston out from caliper housing at least one inch using a suitable adjusting tool (T75P-2588-B). Push piston back into housing with adjusting tool, hold adjusting tool shaft in place and rotate tool handle counterclockwise until thrust screw clears anti-rotation pin. Remove thrust screw and anti-rotation pin.
 2) Remove piston adjuster assembly by installing suitable removal tool (T75P-2588-A) through back of caliper housing and pushing piston out. *NOTE* — Use care not to damage polished surface in thrust screw bore. Remove and discard piston seal, boot, thrust screw "O" ring seal, end retainer "O" ring seal and end retainer lip seal.

Cleaning & Inspection — Clean all metal parts in denatured alcohol or clean brake fluid and dry with compressed air. Inspect all parts for wear or damage and replace as necessary. Check operation of adjuster by assembling thrust screw into piston/adjuster assembly, pulling the two pieces apart by hand approximately .250" and then releasing them. When pulling on the two pieces, brass drive ring must remain stationary, causing nut to rotate. When releasing the two pieces, nut must remain stationary and drive ring must

rotate. If action of components does not follow this pattern, replace piston adjuster assembly.

Reassembly (Rear) — To reassemble, reverse disassembly procedure and note the following: Apply a coat of clean brake fluid to all parts before reassembly. Fill piston/adjuster with clean brake fluid. Install thrust screw into piston/adjuster assembly until top surface is flush with bottom of threaded bore in piston/adjuster assembly. Lubricate all components of parking brake mechanism with a suitable silicone grease.

TIGHTENING SPECIFICATIONS

Application	Ft. Lbs.
American Motors	
Anchor Plate Mounting Bolts.....	80
Caliper Key Retainer Screw	15
Brake Hose-to-Caliper	25
Wheel Attaching Bolts	75
Ford Motor Co.	
Anchor Plate Mounting Bolts ①	
Upper.....	90-120
Lower	90-120
Caliper Key Retainer Screw	12-16
Brake Hose-to-Caliper	10-15
Caliper End Retainer (Rear Only).....	75-95
Parking Brake Lever Retainer Screw.....	16-22
Wheel Attaching Bolts	70-115

① — Upper bolt must be tightened first.

Brake Systems

BENDIX SINGLE PISTON DISC (Cont.)

DISC BRAKE ROTOR SPECIFICATIONS						
Application	Disc Diameter	Lateral Runout	Parallelism	Original Thickness	Minimum Refinish Thickness	Discard Thickness
American Motors All Models	10.75	.003	.0005	1.190	1.120
Ford Motor Co. (Front) Ford, Mercury, Meteor	11.80	.003	.0005 ^①	1.180	1.120
T-Bird, Cont., Mk VI	11.80	.003	.00025	1.180	1.120
Cougar, Torino, Montego, Elite	10.72 ^②	.003	.0005	1.180	1.120
Bobcat, Pinto, Mustang	9.30	.003	.0005	.870810
All Others	11.03	.003	.0005	.870810
Ford Motor Co. (Rear) Granada & Monarch	10.66	.004	.0005	.945895
All Others	11.50	.004	.0004 ^③	.945895

- ① — Mercury - .0004".
 ② — Police vehicles - Same as Ford, Mercury, Meteor.
 ③ — Ford and Mercury .0005".